

TECHNICAL MATHEMATICS GRADE 10

TECHNICAL
MATHEMATICS
GRADE 10

ISBN 978-1-4315-2282-8



9 781431 522828



basic education

Department:
Basic Education
REPUBLIC OF SOUTH AFRICA



SASOL
reaching new frontiers

TECHNICAL MATHEMATICS

GRADE 10

sasol
inzalo
foundation

UKUQONDA
i n s t i t u t e

**Developed and funded as an ongoing project by the Sasol Inzalo
Foundation in partnership with the Ukuqonda Institute**

Published by The Ukuqonda Institute: <http://www.ukuqonda.org.za>

9 Neale Street, Rietondale 0084; Title 21 company, reg. no. 2006/026363/08;

Public Benefit Organisation, PBO Nr. 930035134

© 2015. Copyright in the work is vested in the publisher.

Copyright in the text remains vested in the contributors.

ISBN: 978-1-4315-2282-8

The FirstRand Empowerment Foundation has funded the printing of this book.

This book was developed with the participation of the Department of Basic Education of South Africa (DBE) with funding from the Sasol Inzalo Foundation (SaIF).

Contributors from the Ukuqonda Institute:

Paul van Koersveld, Nathi Makae, Andrew Hofmeyr, Yvonne Thiebaut, Herholdt Bezuidenhout, Enoch Masemola, Makgoshi Manyatshe, Willem van Schalkwyk, Piet Human, Martinette van der Westhuizen, Elene van Sandwyk, Irma van der Vyver, Hettie Vos

Contributors from the Department of Basic Education:

Leonard Gumani Mudau, Elliot Peter Simelane, Gift Mfiki Ndaba, Andrew Nkwana, Glentone Williams, Anna M Orsmond-Pieterse

Illustrations and computer graphics:

Leonora van Staden, Martin van Niekerk, Melany Pietersen

Cover photo: Kim Stevens

Text design: Mike Schramm

Layout and typesetting: Ink Design

Printed by: [printer name and address]

Your freedom to legally copy this book

This work is published under a Creative Commons Attribution-NonCommercial 4.0 Unported License (CC BY-NC 4.0). <http://creativecommons.org/licenses/by-nc/4.0/>



You are allowed to freely copy this book subject to the qualifications below. You can photocopy, print and distribute it as you like. You may download it onto any electronic device, distribute it via email, and upload it to your website, at no charge. You may also adapt the text and illustrations.

Attribution:

When doing any of the above, you should provide clear acknowledgement the license/copyright holders ('attribute the original work'). This attribution should include the name(s) of the original book(s) and the publisher, as well as acknowledgement of the SaIF and the DBE of South Africa. You should also provide the Creative Commons web address, which explains this type of license: <http://creativecommons.org/licenses/by-nc/4.0/>.

If you made changes to the material, you must indicate what changes you have made. You may not in any way suggest that the licensor endorses you or your use of your material or your changes to the material.

Restrictions:

You may not make copies of this book or a part of this book – in printed or electronic or audio or video or whatever form – for a profit-seeking purpose.

Rights of other copyright holders:

All reasonable efforts have been made to ensure that materials included are not already copyrighted to other entities, or in a small number of cases, to seek permission from and acknowledge copyright holders. In some cases this may not have been possible. The publishers welcome the opportunity for redress with any unacknowledged copyright holders.

CONTENTS LIST

CHAPTER 1 Introduction

Preamble	1
1.1 Algebraic language	2
1.2 Some words we use in Algebra	2
1.3 Some mathematical conventions and expressions	3
1.4 Quantities	3
1.5 Relationship between quantities	5
1.6 Properties of operations	5
1.7 Factorisation and expansion	6
1.8 The hidden pattern of the distributive property	7
1.9 Another hidden pattern of the distributive property	8
1.10 Computational properties of Integers	9
1.11 Equivalence	11
1.12 Simplifying expressions	13
1.13 From numerical calculations to algebraic calculations	14
1.14 Modelling some situations	15
1.15 Solution, expression, equation, identity, and impossibility	15
1.16 The scientific calculator	17

CHAPTER 2 Number Systems

Preamble	23
2.1 Real numbers	24
2.2 More about how to represent sets and intervals	29
2.3 Rounding off and significant figures	32
2.4 Rational numbers in more detail	34
2.5 Irrational numbers in more detail	37
2.6 Binary numbers	42
2.7 Complex numbers	55
2.8 Summary	56
2.9 Consolidation exercises	57

CHAPTER 3 Exponents

Preamble	59
3.1 Introducing repeated multiplication	60
3.2 Notation for repeated multiplication and division	61
3.3 The algebra of exponents	65

3.4	Simplifying	66
3.5	Exponential equations	71
3.6	Scientific notation and significant figures	74
3.7	Kilo-, nano-, mega-, micro-, and more	79
3.8	Conversion between units	80
3.9	Summary	84
3.10	Consolidation exercises	85

CHAPTER 4 Algebraic expressions

	Preamble	89
4.1	Revision: Notation for representing sets	90
4.2	Using algebraic expressions	92
4.3	Adding and subtracting of algebraic terms	94
4.4	Multiplication of polynomials	97
4.5	Factorise expressions of the form $ab \pm ac$	100
4.6	Factorise expressions of the form $ax^2 \pm bx \pm c$	102
4.7	Factorising the difference of two squares	109
4.8	Factorising: addition or subtraction of two cubes	112
4.9	Factorising: some mixed examples	114
4.10	Simplifying algebraic fractions (quotient expressions)	114
4.11	Lowest common multiples(LCM) and highest common factors(HCF)	116
4.12	Adding and subtracting algebraic fractions	116
4.13	Multiplying algebraic fractions	122
4.14	Dividing algebraic fractions	124
4.15	Summary	126
4.16	Consolidation exercises	127

CHAPTER 5 Equalities and inequalities

	Preamble	129
5.1	Getting ready to learn	130
5.2	Working with equations	130
5.3	Simultaneous equations	133
5.4	Linear inequalities	136
5.5	Solving linear inequalities	140
5.6	Solving quadratic equations by factorisation	142
5.7	Subject of the formula	143
5.8	Word problems	144
5.9	Summary	146
5.10	Consolidation exercises	147

CHAPTER 6 Trigonometry

Preamble	149
6.1 Introducing two situations	150
6.2 Revision of angles, lengths, length ratios, and similarity	151
6.3 Switching between pitch angles and different roof length ratios with sine, cosine and tangent functions	157
6.4 Right-angled triangles	164
6.5 Defining the trigonometric functions	166
6.6 Input angles of 0° and 90°	171
6.7 The Cartesian grid: looking at the tangent function in a different way	172
6.8 More application of trigonometry functions in the Cartesian plane	176
6.9 Solving equations involving trigonometric functions for angles between 0° and 90°	192
6.10 Solving problems involving right-angled triangles	194
6.11 The graphs of the basic trigonometric functions	201
6.12 Summary	227
6.13 Consolidation exercises	230
Appendix 1	234

CHAPTER 7 Functions and graphs

Preamble	237
7.1 Function notation	238
7.2 Revision of linear functions	238
7.3 Quadratic function $y = ax^2$	241
7.4 Quadratic function $y = ax^2 + q$	243
7.5 Exponential graphs $y = ab^x$	248
7.6 The hyperbola	250
7.7 Reading from graphs	252
7.8 Summary	253
7.9 Consolidation exercises	254

CHAPTER 8 Geometry

Preamble	257
8.1 Revising angles relating to parallel lines	258
8.2 Revising angles relating to triangles	265
8.3 Congruence of triangles	274
8.4 Similarity of triangles	285
8.5 Investigating quadrilaterals	290
8.6 The Pythagorean Theorem	305

8.7	Summary	309
8.8	Consolidation exercises	310
	Addendum	314

CHAPTER 9 Analytical Geometry

	Preamble	315
9.1	Using the Cartesian plane to locate points	316
9.2	Distance between two points	317
9.3	Midpoint coordinates of a line segment joining two points	322
9.4	Gradient of a line segment	324
9.5	Equation of a straight line passing through two points	329
9.6	Summary	330
9.7	Consolidation exercises	331

CHAPTER 10 Circles, Angles, and Angular Movement

	Preamble	333
10.1	Preparing to learn	334
10.2	Revisiting π	335
10.3	Measuring angles: Degrees ($^{\circ}$)	337
10.4	Converting from degrees to radians	343
10.5	Summary	346
10.6	Consolidation exercises	347

CHAPTER 11 Finance and Growth

	Preamble	349
11.1	Investing through simple interest	350
11.2	Investing through compound interest	355
11.3	Hire purchase	360
11.4	Inflation	363
11.5	Exchange rates	367
11.6	Summary	369
11.7	Consolidation exercises	370

GLOSSARY 373

ANSWERS 377

1 INTRODUCTION

In this chapter, you will:

- revise some concepts we use in algebra
- be reminded of some mathematical conventions
- acquaint yourself with your calculator, as well as use it as a learning tool
- revise base quantities that we use in science technology, and in our daily lives
- revise the order of operations
- revise properties of operations
- revise computational properties of integers
- revise the concept of equivalence
- simplify algebraic expressions
- model some situations
- talk about expressions, equations, and identities

1.1 Algebraic language

Exercise

- 1 Do you remember what the following mathematical terms mean? Copy and complete the table below.

		Explanation/meaning	Example(s)
(a)	Product		
(b)	Quotient		
(c)	Sum		
(d)	Difference		
(e)	Factor		
(f)	Additive inverse		
(g)	Multiplicative inverse		
(h)	Identity for addition		
(i)	Identity for multiplication		
(j)	Coefficient		
(k)	Solution		
(l)	Reciprocal		
(m)	Input variable		
(n)	Output variable		

1.2 Some words we use in Algebra

When we join numbers or add numbers to each other, such as $5x + 3x$ we call it **addition**.

Subtraction is the process of subtracting or deducting one number from another, e.g. $13y - 12y$.

The abbreviated process of adding numbers to each other a certain number of times is called **multiplication**, such as $2 \times 3y \times 6x$.

When we use the process of **dividing** a number into parts, we really want to see how many times a number is contained in another.

An expression with one term only, like $6x^2$, is a **monomial**.

An expression that is a sum of two terms like $-3x + 7$ is called a **binomial**.

An expression that is a sum of three terms like $100x^3 + 45x^2 - 50x$, is called a **trinomial**.

The symbol x is often used to represent the **variable** in an algebraic expression but other letter symbols may be used.

In the monomial $-15x^3$, -15 is the coefficient of x^3 .

In the binomial $17x - 3$, and the binomial $33x^2 + 14$, the numbers -3 and 14 are called **constants**.

Exercise

2 Complete the table, using the completed first row as an example.

	Expression	Type of expression	Symbol used to represent the variable	Constant	Coefficient of
(a)	$3x^2 - 7x + 9$	Trinomial	x	9	x is -7
(b)	$5s^3 - 11$				s^3 is
(c)	$-1, 2t + \pi$				t is
(d)	$105k$			0	k is
(e)	$11 - p + p^3$				p^3 is

1.3 Some mathematical conventions and expressions

Mathematicians have agreed upon certain things that make mathematical work much easier if everyone adheres to these agreements.

- **Multiplication sign:** The multiplication sign is often omitted in algebraic expressions. $5 \times p$ is written as $5.p$, as well as $5p$, and we write $-3(a + 4)$ instead of $-3 \times (a + 4)$.
- **Writing a product with a number and a letter symbol:** It is common practice to write a known number (constant) first in a product; we write $11a$ instead of $a11$.
- **When the number before a letter symbol is 1:** It is common practice to drop the coefficient 1 in a number such as $1a$ and instead just write a or in the case of $-1a$ we just write $-a$.

1.4 Quantities

Engineers, surveyors, scientists, and ordinary citizens encounter and work with quantities of different kinds every day. A **quantity** is anything that we can measure or count. Your height is a quantity, we can measure it. If you are 1,8 m tall, 1,8 is a number and metre is a unit of measure.

Exercise

3 Give your own examples of quantities and their units of measurement. You may want to organise your information in a table such as the one below.

Quantity	Unit of measure

There is an internationally agreed upon system of units known as the International System of Units, abbreviated as **SI**. There are seven base quantities on which the SI is founded. You have worked with some of these quantities in your studies already.

Exercises

4 Copy and complete the table below.

Base quantity	SI (International System of Units) base units	
	Name	Symbol
thermodynamic temperature	kelvin	K
amount of substance	mole	mol
luminous intensity	candela	cd
length		
mass		
time		
electric current		

5 Name appropriate units for measuring:

- (a) The amount of cement that a bag will hold.
- (b) The amount of sand that can be transported in a bakkie.
- (c) The height of a school building.
- (d) The distance between Johannesburg and Cape Town.
- (e) The capacity of petrol in a car.

6 Name an item that can be used to estimate the following metric units:

- (a) a centimetre
- (b) a metre
- (c) a litre
- (d) a kilometre
- (e) a kilogram

1.5 Relationship between quantities

Exercise

- 7 Determine whether the pairs of quantities below are related to each other. If so, explain whether the value of the quantity given on the right increases or decreases as the value of the corresponding quantity on the left increases.

(a)	Number of minutes that have passed while driving a car at 120 kilometres per hour.	Amount of petrol in the petrol tank.
(b)	Number of sweets eaten.	Number of calories consumed.
(c)	Perimeter of a square.	Area of the square.
(d)	Number of minutes that have passed while driving a car at 120 kilometres per hour.	Amount of petrol consumed by the car.
(e)	The base of a triangle.	The area of a triangle.
(f)	A radius of the circle.	The circumference of the circle.

1.6 Properties of operations

Operations with numbers have the following properties:

The distributive property

The **distributive property** simply means that if a number is broken into parts and each part is multiplied, the answer is the same as when the number is multiplied as a whole.

Example: $5 \times 27 = 5 \times 20 + 5 \times 7$ (We have broken 27 into 20 and 7.)

We can express the distributive property in a general mathematical way by saying that if a , b , and c are any three numbers, then $a(b + c) = ab + ac$.

We also say multiplication distributes over addition.

Exercises

- 8 Calculate, without using a calculator, the value of the following. It is important to show your work.
- (a) $181,5 \times 3 + 181,5 \times 7$ (b) $703 \times 8 + 703 \times 2$ (c) $17 \times 43 + 17 \times 57$

9 Check by inspection whether the following expressions will produce the same answer. Give a reason for your answer.

(a) 35×112 and $35 \times 100 + 35 \times 12$ (b) $2(x + y)$ and $2x + y$

10 Check by inspection whether the following expressions will produce the same answer. Give a reason for your answer.

(a) $70 \times 17 - 70 \times 7$ and 70×10 (b) $53 \times 22 - 53 \times 2$ and 53×20

The commutative property of multiplication and addition

The **commutative property** of multiplication simply means that changing the order of factors in multiplication does not change the answer. For example: $15 \times 11 = 11 \times 15$

We also notice that: $15 + 11 = 11 + 15$.

The commutative property for addition simply means that changing the order in which numbers are added does not change the answer.

In general, if x and y are any numbers, then $xy = yx$ and $x + y = y + x$

The associative property for multiplication and addition

The **associative property** for multiplication simply means that the order in which you multiply the numbers does not change the answer.

The associative property for addition simply means that the order in which we add numbers does not change the answer.

In general, if x , y , and z are any numbers, then the following is always true:

$$xyz = xzy = yzx \text{ and } x + y + z = x + z + y = y + z + x$$

1.7 Factorisation and expansion

Expressing numbers or algebraic expressions as products of their factors is called **factorisation**.

We can write a number as a product of its factors. For example, 35 can be written as 7×5 .

$35 = 7 \times 5$ or $35 = 5 \times 7$ (because of the commutative property of multiplication).

We can express an algebraic expression such as $xy + xz$ as a product of its factors, $x(y + z)$.

We can also express $xy - xz$ as a product expression $x(y - z)$.

Exercises

11 Write the following numbers as products of its factors. (More than one way may be possible.)

(a) 12

(b) -24

(c) 17

12 Write each of the expressions below as a product expression.

(a) $ax + bx$

(b) $6x - 3$

(c) $4 + 16x$

(d) $7x^2 - x$

(e) $5x - 15$

(f) $14 - 7x^2$

(g) $3x - 3$

(h) $15x - 6$

1.8 The hidden pattern of the distributive property

Sum expressions such as $x^2 + 2xy + y^2$ seem not to match $xy + xz$ but when we decompose the expression $x^2 + 2xy + y^2$ we get:

$$x \cdot x + xy + xy + y \cdot y$$

$$= (x \cdot x + xy) + (xy + y \cdot y)$$

$$= x(x + y) + y(x + y)$$

$$= (x + y)(x + y)$$

And so, using the distributive property we can factorise $x^2 + 5x + 6$ as shown below:

$$x^2 + 5x + 6$$

$$= x \cdot x + 2x + 3x + 6$$

$$= x(x + 2) + 3(x + 2)$$

$$= (x + 2)(x + 3)$$

Exercise

13 Factorise each of the expressions below.

(a) $a^2 + 4a + 3$

(b) $4x^2 + 8x + 2$

(c) $x^2 + 2x + 1$

(d) $ac + bc + ad + bd$

(e) $x(a + b) + (a + b)$

(f) $15x^2 - 6x$

Expansion

When we write a product expression as a sum expression we say we have **expanded** the given expression.

Expand $(x + 1)(x + 3)$

$$= x(x + 3) + 1(x + 3)$$

$$= x^2 + 3x + 1x + 3$$

$$= x^2 + 4x + 3$$

Exercises

14 Expand each of the expressions below:

(a) $(a - b)(a + b)$

(b) $(a + b)(a + b)$

(c) $(a - b)(a - b)$

(d) $(p + q)(p + q)$

(e) $(p - q)(p - q)$

(f) $(p + q)(p - q)$

(g) $(a + b)(c + d)$

(h) $(a + b)(c - d)$

(i) $(x + 3)(x + 3)$

(j) $(x + 3)(x - 3)$

(k) $(x - 3)(x - 3)$

1.9 Another hidden pattern of the distributive property

It can also be said of an expression such as $x^2 - 9$ that it does not seem to match $xy + xz$. However, we can decompose the expression $x^2 - 9$ as shown below:

$$x^2 - 9$$

$$= x^2 + 0x - 9 \quad (\text{adding } 0x \text{ to the expression } x^2 - 9 \text{ does not change its value)}$$

$$= x^2 + 3x - 3x - 9 \quad (+ 3x - 3x = 0; + 3x \text{ and } -3x \text{ are additive inverses)}$$

$$= x \cdot x + 3x - 3x + 3 \cdot 3$$

$$= x(x + 3) - 3(x + 3)$$

$$= (x + 3)(x - 3)$$

Exercises

15 Now, factorise each of the following expressions:

(a) $x^2 - 4$

(b) $9 - x^2$

(c) $x^2 - 121$

(d) $121 - x^2$

(e) $169 - 4x^2$

(f) $4x^2 - 169$

(g) $25 - x^2$

(h) $x^2 - 25$

(i) $p^2 - 1$

(j) $1 - p^2$

16 Calculate the square of each of the following numbers without using a calculator:

1, 2, 3, 4, 5, 6, 7, 8, 9, 10, 11, 12, 13, 14, 15, 16, 17, 18, 19, 20, 21, 22, 23, 24, 25

17 Calculate the value of each of the following without using a calculator. What do you notice? Try to explain the relationship between the two sets of calculations.

(a) $11^2 - 9^2$ and 20×2

(b) $12^2 - 8^2$ and 20×4

(c) $13^2 - 7^2$ and 20×6

(d) $14^2 - 6^2$ and 20×8

(e) $15^2 - 5^2$ and 20×10

18 Now, apply the knowledge you developed from doing exercise 17 above to calculate:

(a) $2\,341^2 - 2\,336^2$

(b) $100^2 - 99^2$

(c) $1\,000^2 - 999^2$

1.10 Computational properties of integers

Copy the table and complete the last column.

Computational property	Example	Your own example
Subtracting a bigger number from a smaller number results in a negative number.	$10 - 30 = -20$	
Adding an integer has the same effect as subtracting its additive inverse.	$3 + (-10)$ can be calculated by doing $3 - 10 = -7$	
Subtracting an integer has the same effect as adding its additive inverse.	$3 - (-10)$ can be calculated by doing $3 + 10 = 13$	
A negative number added to the corresponding positive number gives 0.	$3 + (-3) = 0$	
The product of a negative number and a positive number is a negative number.	$(-15) \times 6 = -90$	
The product of a negative number and another negative number is a positive number.	$(-15) \times (-6) = 90$	

Exercises (no calculator to be used for this exercise)

19 You may want to refer to the table of computational properties of integers above in order to do the exercise below. Copy and complete computational tables 1 and 2 shown on the next page. (Your teacher may give you a copy of the table that you have to complete; paste in your exercise book.)

On your calculator there are these keys: $(-)$ and $-$.

The first key is used to enter negative numbers and the second key is used only for subtraction.

Computational Table 1

+	-50	-40	-30	-20	-10	0	10	20	30	40	50
-50											0
-40										0	
-30									0		
-20								0			
-10							0				
0						0					
10					0						
20				0							
30			0								
40		0									
50	0										

Computational Table 2

×	-5	-4	-3	-2	-1	0	1	2	3	4	5
-50						0					
-40						0					
-30						0					
-20						0					
-10						0					
0	0	0	0	0	0	0	0	0	0	0	0
10						0					
20						0					
30						0					
40						0					
50						0					

- 20 If you have any circuit with many loops, the algebraic sum of the voltages around any loop in the circuit is zero; this is known as Kirchoff's Voltage Law.

A closed circuit is shown in the figure that follows. Check whether or not the voltage drops given in the figure conform to Kirchoff's Voltage Law.

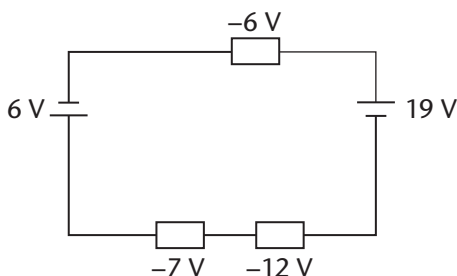

1.11 Equivalence

Numerical expressions

Algebraic expressions that have the same numerical values (answer) are called **equivalent numerical expressions**.

Exercises

- 21 State whether the following pairs of expressions are equivalent or not:
- (a) $20 + (30 + 70)$ and $20 + 30 + 70$
 - (b) $20 + (30 - 70)$ and $20 + 30 - 70$
 - (c) $20 - (30 + 70)$ and $20 - 30 - 70$
 - (d) $20 - (30 - 70)$ and $20 - 30 + 70$

Algebraic expressions

Algebraic expressions that have the same numerical value for all values of the numbers represented by letters are called **equivalent expressions**. Two algebraic expressions $2x + 3x$ and $5x$ are equivalent because they have the same values for any input variable x . We can write this using mathematical language and convention as $2x + 3x = 5x$ for all values of x .

Consider the following table as a way of checking. However, you need to be aware that we cannot write all the possible values of the input variable x to check whether or not the answers will always be equal.

x	-17	-9	-4	-1	0	7	11	20	45
$2x + 3x$	-85	-45	-20	-5	0	35	55	100	225
$5x$	-85	-45	-20	-5	0	35	55	100	225

Worked example

Are the following algebraic expressions equivalent?

$$(b + 2) - (b - 5) \text{ and } (b + 2) - b + 5$$

To decide, Thandeka replaces the number b with 8 in the expressions as done in the table above:

$$\begin{array}{ll} (b + 2) - (b - 5) & \text{and} & (b + 2) - b + 5 \\ = (8 + 2) - (8 - 5) & & = (8 + 2) - 8 + 5 \\ = 10 - 3 & & = 10 - 8 + 5 \\ = 7 & & = 7 \end{array}$$

Throshini says to Thandeka that she can show that the two expressions are equivalent without replacing b with numbers. How do you think Throshini shows Thandeka that the two expressions are equivalent?

Exercises

22 Use Throshini's method to state whether the following pairs of expressions are equivalent or not:

- (a) $20x + (30x + 70)$ and $20x + 30x + 70$
- (b) $20x + (30x - 70)$ and $20x + 30x - 70$
- (c) $20x - (30x - 70)$ and $20x - 30x + 70$
- (d) $20x - (30x + 70)$ and $20x - 30x - 70$
- (e) $a - (150 + 205)$ and $a - 150 - 205$
- (f) $1200 - (500 + a)$ and $1200 - 500 - a$
- (g) $708 - (a + b)$ and $708 - a + b$
- (h) $b + 419 - a$ and $b + (419 - a)$

The idea of equivalence is useful in that it allows us to replace one expression with another because the equivalent expressions represent the same number, or we say they have the same value.

For any numbers x , y , and z :

- $x + (y + z) = x + y + z$
- $x + (y - z) = x + y - z$
- $x - (y + z) = x - y - z$
- $x - (y - z) = x - y + z$

We can therefore replace expressions on the left with those on the right and vice versa.

1.12 Simplifying expressions

When we write an expression in a convenient way, we say we have **simplified** it. We simplify an expression by:

- Combining like terms $26x + 4x$ can be replaced by the simpler expression $30x$ because they will give the same result for any value of x . We say $26x$ and $4x$ are like terms.
- Rearranging the terms of the expression because the order in which numbers are added does not affect the answer, for example:

$$(-3x + 14) + (5x + 26) = -3x + 14 + 5x + 26 = -3x + 5x + 14 + 26 = 2x + 40$$

Note that unlike terms $2x + 40$ cannot be replaced by $42x$. We say $2x$ and 40 are unlike terms.

Worked example

The expression $x(x + 2) - 7x$ simplifies to $x^2 - 5x$ as shown below:

$$\begin{aligned}x(x + 2) - 7x \\&= x^2 + 2x - 7x \\&= x^2 - 5x\end{aligned}$$

Exercises

23 What is the value of each expression if $x = 23,45$ and $y = 13,92$?

- (a) $25x - (7x + 5)$
- (b) $13x + 5 - (10x - 4)$
- (c) $12x + (4y - 5x) + 7x - 2y$
- (d) $(3,3x + 2,1y) - (1,4y - 1,7x) - (4x + 0,7y)$

24 Determine the value of the following expressions if $x = 7,3$. Do not use a calculator.

- (a) $4x + 3 + 6x + 2$
- (b) $2(5x + 3)$
- (c) $(2 + 17x) - (7x + 5)$
- (d) $1,3x + 3,7x + 2,6x + 2,4x$

25 How much will $3x(6x + 10) - 9x(2x + 3)$ be if $x = \frac{3}{2}$?

1.13 From numerical calculations to algebraic calculations

The number 5 432 in expanded form, can be written as $5\,000 + 400 + 30 + 2$ and this can be further expanded as $5 \times 1\,000 + 4 \times 400 + 3 \times 10 + 2$.

Furthermore, numbers can be written in an expanded form using exponents and then written in polynomial form:

$$5\,432 = 5 \times 10^3 + 4 \times 10^2 + 3 \times 10 + 2$$

A polynomial form for 5 432 is $5x^3 + 4x^2 + 3x + 2$ ($x = 10$)

Exercises

26 Write each of the following numbers first in an expanded form using exponents, and then give the suggested polynomial.

(a) 9 876

(b) 357

(c) 2 468

(d) 123

27 Use the numerical calculation to think about the algebraic calculation. Write down the following algebraic additions in your exercise book. Complete and give the answer to the algebraic calculation.

(a)
$$\begin{array}{r} 7x^3 + 6x^2 + 5x + 4 \\ + 4x^3 + 3x^2 + 2x + 1 \\ \hline \end{array}$$

(b)
$$\begin{array}{r} 9x^2 + 8x + 7 \\ + 3x + 2 \\ \hline \end{array}$$

(c)
$$\begin{array}{r} 9x^2 + 8x + 7 \\ + 4x + 3 \\ \hline \end{array}$$

(d)
$$\begin{array}{r} 9x^2 + 8x + 7 \\ - 4x^2 - 3 \\ \hline \end{array}$$

(e)
$$\begin{array}{r} 9x^2 + 8x + 7 \\ - 3x^2 - 2 \\ \hline \end{array}$$

28 Calculate the sum and product of the polynomials in each part.

(a) $x + 2$ and $x - 3$

(b) $-x + 1$ and $x + 1$

(c) $1,2x$ and $10x + 3$

(d) $0,7x + 4$ and $0,3x + 6$

(e) $2x + 1$ and $x - 1$

1.14 Modelling some situations

In algebra, we use letters of the alphabet to represent quantities and relationships between and among quantities.

Exercises

29 Write a formula to describe the relationship between each of the quantities below.

- There are seven days in a week.
- There are sixty minutes in an hour.
- At one school, there are 25 times as many learners as teachers.
- Explain what each letter you have used in each of the formulas in (a) – (c) above stand for.
- Test each formula by completing the tables below.

29 (a)	Number of weeks	1	2	3	4	5	12	24	33	52
	Number of days									

29 (b)	Number of hours	1	2	3	6	18	24	36	48	60	72
	Number of minutes										

29 (c)	Number of learners	100	200	300	350	405	600	660	809	1000	1800
	Number of teachers										

1.15 Solution, expression, equation, identity, and impossibility

In the previous sections, we have talked about simplifying algebraic expressions. An algebraic expression such as $5x + 3$ is equal to any number, depending on the value of x .

Exercises

30 Copy and complete the table below for the given value of x .

x	-10	-5	-1	0	8	14	20	23	50
$5x + 3$									

31 Consider your completed table in question 30 and use it to answer the questions below.

- (a) For what value of x is $5x + 3 = 103$?
- (b) For what value of x is $5x + 3 = 3$?
- (c) For what value of x is $5x + 3 = -2$?
- (d) For what value of x is $5x + 3 = -47$?

A mathematical statement such as $5x + 3 = 103$ might be true or it might be false, it depends on the value of x we have chosen. The statement $5x + 3 = 103$ is only true if $x = 20$. Any other value of x makes the statement false.

32 What do we call an algebraic statement that is true for some values of an input variable?

Solutions

The **solution** of an equation is the value(s) of the input variable that make the equation a true mathematical statement. As we have observed, the equation $5x + 3 = 103$ has only one solution, namely $x = 20$. An equation will either have one solution, no solution, or many solutions. An algebraic statement like $2x + 3x = 5x$, which is true for all values of the input variables, is called an **algebraic identity**.

An algebraic statement such as $x + 10 = x$ is called an **algebraic impossibility**; there is no value(s) of x that can make the statement a true mathematical statement.

Exercises

Consider the algebraic expressions below:

33 $4x + 12$ and $7x + 3$

- (a) Are these two expressions equivalent? Explain.
- (b) Is $4x + 12 = 7x + 3$ an algebraic identity? Explain.
- (c) What happens when $x = 3$?

34 $10x + 40 = 10x + 50$

- (a) Is $10x + 40 = 10x + 50$ an algebraic identity?
- (b) Is it possible to find any value of x for which $10x + 40 = 10x + 50$?

- 35 Give an example in each case; state for what value(s) of x (if any) each of the statements are true by marking with a cross where appropriate.

	Statement	True for any value of x	Never true for any value of x	True for some value(s) of x (state the value(s) of x for which the statement is true)
(a)	$2x + 6 = 24$			
(b)	$2x + 6 = 2(x + 3)$			
(c)	$2x + 6 = 2x + 3$			
(d)	$2x + 6 = 3x + 1$			

1.16 The scientific calculator

There is no specific scientific calculator prescribed for this subject. Any scientific, non-programmable calculator is suitable for your studies. Different scientific calculators have different functions and it is up to you to know your calculator.

Most scientific calculators have algebraic logic; the operation in an expression can be entered in the calculator in the order in which the expression is read (left to right). The calculator automatically follows the conventional order of operations.

Configuring the calculator setup

You can setup your calculator to work either in natural display or linear display. Natural display causes fractions, irrational numbers, expressions, and certain functions to be displayed as you see them on paper. Linear display causes fractions and other expressions to be displayed in a line. (You have to consult your calculator manual for this.)

Order of operations

When we come across an expression such as $7 + 3 \div 10 \times 1$, it makes a difference how we choose which operations to perform first.

Exercises

- 36 Calculate the value of the expression $7 + 3 \div 10 \times 1$ without using a calculator.
- 37 Now calculate the value of the expression using a calculator.
- 38 Did you get the same answer as that of the calculator?
- 39 Think about the order in which you performed the various operations. Does the calculator follow your order?

Scientific calculators have been programmed to follow preset mathematical rules. If we press the buttons in a certain order, the calculator does the operations according to the rules that it has been programmed with. You will use a scientific calculator in the exercise below.

Exercises

40 Copy the following table in your exercise book. First calculate the value of the number expression in the table in your own way. Then use a scientific calculator to calculate the value of the expression.

	Number expression	Without the use of a calculator find the answer	Scientific calculator's answer	Explain the discrepancy in answers if any
(a)	$40 + 50 \times 10$			
(b)	$12 \times 5 + 7$			
(c)	$20 \times 5 + 3 \times 10$			
(d)	$11 + 9 \times 2 + 1$			
(e)	$34 + 3 \times 11 \times 2$			
(f)	$2 \times 50 \times 301$			
(g)	$2 + 50 + 301$			
(h)	$107 \times (1\,293 - 981)$			
(i)	$(27 + 73) \times (4\,659 - 3\,659)$			
(j)	$2\,028 \div 169 - 12$			
(k)	$12 \div 2 \times 6$			
(l)	$12 \times 6 \div 2$			
(m)	$50 + 2 - 30$			
(n)	$50 - 30 + 2$			
(o)	$1 + 3^2$			
(p)	$(1 + 3)^2$			
(q)	$1^2 + 3^2$			
(r)	$1^2 + 2 \times 3 + 3^2$			
(s)	$5 + 3(1 + 9)^2 - 2^3$			
(t)	$(\sqrt{64} + 2)3 + 20 \times 5 - 5$			

41 Replace each of the asterisks (*) with the correct arithmetic operator in order for the calculation to be true. Do not use brackets.

(a) $12 * 5 * 2 * 1 = 3$

(b) $18 * 12 * 3 * 2 = 12$

(c) $24 * 4 * 2 * 3 = 7$

(d) $12 * 4 * 6 * 2 = 11$

(e) $60 * 20 * 50 = 30$

42 Place brackets and the operational signs +, −, ×, ÷, in the correct places to make the following statements true.

(a) $12 * 3 * 1 = 5$

(b) $20 * 5 * 2 * 3 = 5$

(c) $24 * 6 * 2 * 2 * 4 = 2$

(d) $8 * 3 * 8 * 3 = 8 * 8 * 3 * 3$

Calculation with a constant

You can do repeated operations with the same number by using a specific key sequence on your calculator.

Follow the following key sequence on your calculator:

Key sequence 1: $3 + 3 =$

Key sequence 2: $+ 3 =$

Key sequence 3: $= = = = =$

Does your calculator generate the sequence 3; 6; 9; 12; 15; 18...?

Exercises

43 Choose a key sequence on your calculator to make a \longrightarrow +11 \longrightarrow machine as follows:

Write down the first 5 numbers of the sequence generated by your calculator, starting at 11.

44 Complete the table below. Do not use a calculator for this exercise.

Term position	1	2	3	4	5	10	17	23	35	100
Term	3	6	9	12	15					

45 Choose a key sequence on your calculator to make a \longrightarrow -10 \longrightarrow machine:

Start at 50 and write down the next 5 terms in the sequence.

(a) What term occupies the 12th position in the sequence?

(b) What term occupies the 24th position in the sequence?

(c) What term occupies the 43rd position in the sequence?

46 Choose a key sequence on your calculator to make a  machine as follows:

- (a) Key sequence 1: Press 2
 (b) Key sequence 2: $\times 3$
 (c) Key sequence 3: =
 (d) Key sequence 4: $\times 3$
 (e) Key sequence 5: = = = = =

47 (a) Write down the first three terms of the sequence you have just generated in question 46 above.

(b) Now complete the table below. You may use your calculator.

Term position	1	2	3	13	25	46	57	88	91
Term	2	6	18						

48 For each of the following, choose a key sequence on your calculator to generate the given sequence of numbers.

- (a) 30; 60; 90; 120; ...
 (b) 3; 10; 17; 24; ...
 (c) 1; 3; 9; 27; ...
 (d) 1; 2; 4; 8; ...
 (e) 1 000; 900; 800; ...
 (f) 1 000; 500; 250; ...

Powers

In the expression y^x , the letter y represents the base and the letter x represents the exponent or index. Therefore, y^x is called the power. We say the base y is raised to the exponent x .

Exercises

49 Use your calculator to simplify:

- (a) 5^3
 (b) 3^5
 (c) $1,5^{2,1}$
 (d) $1,5^2$
 (e) -3^2
 (f) $(-3)^2$
 (g) $(-3)^2$
 (h) $-(3)^2$

The square and the square root keys

If $x^2 = 25$, the solution of this equation is called the square root of 25. The number 25 has two square roots, namely, 5 and -5 . We call 5 the principal square root or positive square root of 25. The symbol $\sqrt{\quad}$ is used for the principal square root. Thus, your calculator will give the answer to $\sqrt{25}$ as 5 and not as -5 .

Exercises

50 Find a sequence of keys that you would press in each of the cases given below. Copy and complete the following table.

	Calculation to be done	Your answer	Calculator answer	Explain the discrepancy if any
(a)	3^2			
(b)	$9 + 4^2$			
(c)	$(9 + 4)^2$			
(d)	$\sqrt{(9 + 4)^2}$			
(e)	$\sqrt{9^2 + 4^2}$			
(f)	$\sqrt{9 + 4}$			
(g)	$\sqrt{3^2}$			
(h)	$9 + \sqrt{4^2}$			
(i)	$\sqrt{9 + \sqrt{4^2}}$			

Calculations with fractions

We have already mentioned that a calculator with algebraic logic allows us to enter the expression in the calculator as it is read. Such calculations are called chain calculations. When working with fractions it is necessary to consider the meaning of fraction notation.

Worked example

Compute $\frac{8,74 + 9,48}{5,6 \times 3,4}$ with your calculator.

Division notation: $(8,74 + 9,48) \div (5,6 \times 3,4)$

Key sequence 1: $(8,74 + 9,48) \div (5,6 \times 3,4) =$

Key sequence 2: $8,74 + 9,48 = \div 5,6 \div 3,4 =$

Did you get the same answer in the two different key sequences?

Exercises

51 Compute each of the following to check that the three notations are equivalent in each case. Both division notations in section A are chain calculations that can be used as calculator key sequences for calculations with fractions.

In Section B, you will learn more about your calculator using either the natural display or the linear display.

Section A			Section B	
Fraction notation	Division notation with brackets	Division notation without brackets	Sequence of buttons to press	
			Natural display	Linear display
$\frac{5}{6}$	-	$5 \div 6$		
$7\frac{3}{4}$	$(7 \times 4 + 3) \div 4$	$7 + 3 \div 4$		
$\frac{12}{4 \times 3}$	$12 \div (4 \times 3)$	$12 \div 4 \div 3$		
$\frac{15}{7+8}$	$15 \div (7 + 8)$	-		
$\frac{7+8}{15}$	$(7 + 8) \div 15$	-		
$\frac{9+6}{3+12}$	$(9 + 6) \div (3 + 12)$	-		
$\frac{5}{7} + \frac{2}{7}$	$(5 \div 7) + (2 \div 7)$	$5 \div 7 + 2 \div 7$		
$\frac{7}{8} \times \frac{3}{5}$	$(7 \div 8) \times (3 \div 5)$	$7 \div 8 \times 3 \div 5$		
$8 \div \frac{2}{3}$	$8 \div (2 \div 3)$	$8 \div 2 \times 3$		

52 If a , b , and c represent numbers, write key sequences (as in the example given in the introduction: Calculation with fractions) for each of the following expressions. You can check by using numbers convenient to you where necessary.

(a) $\frac{a+b}{c}$

(b) $a + \frac{b}{c}$

(c) $\frac{a+b}{a+c}$

(d) $a + \frac{b}{a+c}$

(e) $a + \frac{b}{a} + c$

(f) $\frac{a}{bc}$

(g) $\frac{a}{b} + \frac{a}{c}$

(h) $\frac{a}{b+a+c}$

The x^{-1} key

The x^{-1} key is used to enter the reciprocal or multiplicative inverse of a number in the calculator. See if you can find the following on your calculator:

Expression	Key sequence
$\frac{2}{5}$	$2 \times 5x =$
$3 + \frac{1}{5}$	$2 + 5x^{-1} =$

2 NUMBER SYSTEMS

In this chapter, you will:

- classify real numbers into sets and learn the symbols for the different sets
- represent sets of numbers on the number line as sets of points
- represent sets of numbers in interval notation and set notation
- revise rounding off
- improve your understanding of the relationship between rational numbers and irrational numbers
- learn how to express integers in binary form and how to do arithmetic with binary numbers
- be introduced to imaginary numbers, these numbers are not real numbers but they are closely related to real numbers.

2.1 Real numbers

Real numbers are the numbers we deal with every day. As you have probably seen in the past, we classify them in an organised manner as follows:

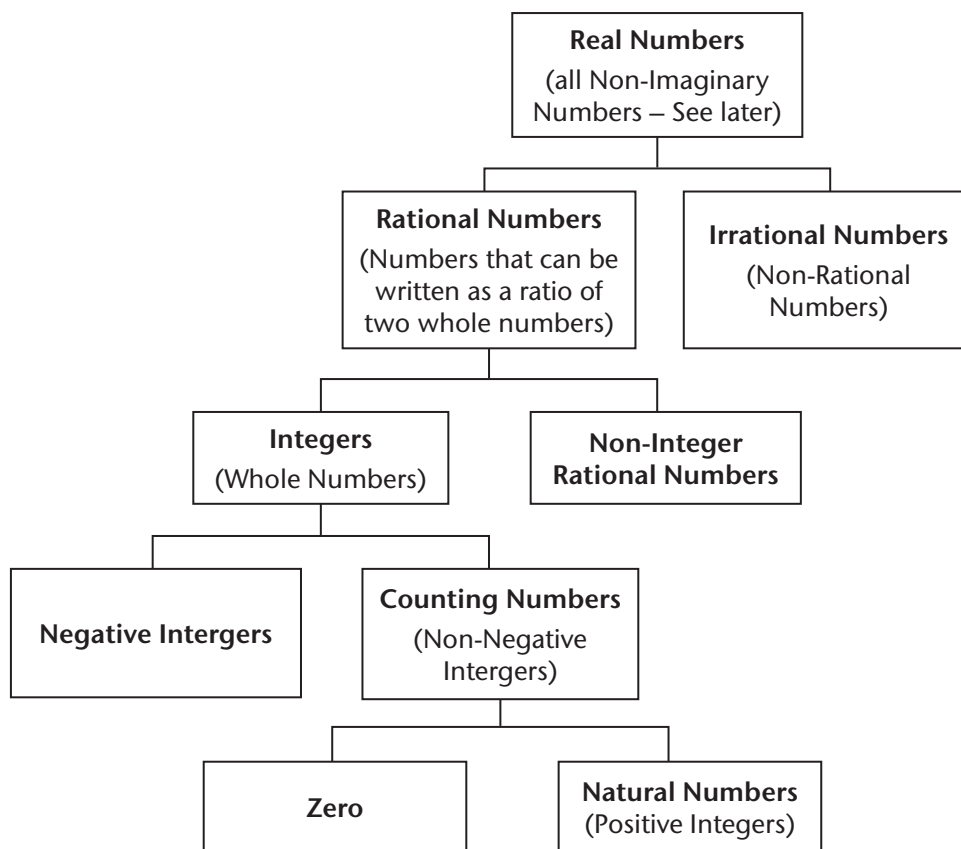

We call each of the ‘collections’ of numbers a **set**. The sets that are linked to the ones above them are called **subsets**. When a number belongs to a set, it is called an **element** of the set. This arrangement is called a **hierarchy** or a hierarchical structure. How to understand the diagram:

- the connecting lines show which sets are linked to each other directly
- the numbers in any set are also in all the sets that may lie above as you follow the connecting lines

For example, your class can be regarded as a set. Therefore, you and the learners in your class are regarded as elements of that set.

Another example, you are also an element of your school, which is the set of you and all your schoolmates. Your class is a subset of the school.

Example How the sets are related

- The set of integers is a subset of the set of rational numbers.
- The set of rational numbers is a subset of the set of real numbers.
- This means that the set of integers is also a subset of the set of real numbers.
- The number 0,56 is a non-integer rational number and also a real number but it is not an integer. The counting number 7 is clearly an integer, but 7 is also a rational number and a real number.
- A counting number is either zero or a positive integer, e.g. 7 is a positive integer and also not zero. The set to which only 0 belongs has only one number in it!
- The number $\pi = 3,141\ 592\ 653\ 589 \dots$ is irrational. This means that π only belongs to two sets in the hierarchy: the set of irrational numbers and also the set of real numbers.

We have special symbols for most of these sets. So, e.g. instead of writing *the set of real numbers* we just write \mathbb{R} . Here is a full list of the symbols for each of the sets:

the set of real numbers	\mathbb{R}
the set of rational numbers	\mathbb{Q}
the set of irrational numbers	$\mathbb{R} - \mathbb{Q}$ or \mathbb{Q}'
the set of integers	\mathbb{Z}
the set of non-integer rational numbers	$\mathbb{Q} - \mathbb{Z}$
the set of counting numbers (non-negative integers)	\mathbb{N}_0
the set of positive integers (natural numbers)	\mathbb{Z}^+ or \mathbb{N}
the set of negative integers	\mathbb{Z}^- or $\mathbb{Z} - \mathbb{N}_0$
the set containing only zero	$\{0\}$

Writing $\mathbb{R} - \mathbb{Q}$ is a formal way of saying '*all the real numbers excluding the rational numbers*'. We can call this 'set subtraction' so long as we understand that it is not the same as the subtraction we do with numbers.

Set subtraction is about excluding some elements from a set. In $\mathbb{R} - \mathbb{Q}$, we have excluded all the rational numbers from the set of real numbers, leaving only the irrational numbers.

This 'set subtraction' is normally given a more formal name; '*the complement of set \mathbb{Q} in set \mathbb{R}* '. Many mathematicians prefer to write $\mathbb{R} - \mathbb{Q}$ as $\mathbb{R} \setminus \mathbb{Q}$, which is read, 'set \mathbb{R} excluding set \mathbb{Q} '. You may do so as well if you prefer.

Example Classifying some numbers

- A. 2 is a natural number, a counting number, a rational number, and a real number. It is *neither* a negative integer *nor* an irrational number.
- B. 0,578 5 is a rational number (since 0,578 5 can be written as the fraction $\frac{5\,785}{10\,000}$ or as the ratio 5 785:10 000) a non-integer rational number and a real number. It is *not* an integer (or anything lower in the hierarchy) or an irrational number.
- C. $\sqrt{3}$ is an irrational number (we'll explain why later) and a real number. It is not a rational number (or anything lower in the hierarchy).
- D. Numbers such as $\sqrt{2}$ are called surds. True surds are never rational. 'Surds' that are rational are ones where the number under the root sign are perfect squares, perfect cubes etc. For example, $\sqrt{1,21} = 1,1$ is rational because 1,21 is a perfect square ($1,1 \times 1,1 = 1,21$) but $\sqrt[3]{1,21}$ is irrational because 1,21 is not a perfect cube; $\sqrt[3]{27}$ is rational, but $\sqrt[3]{9}$ and $\sqrt[3]{3}$ are irrational.
- E. $\sqrt{-1}$ is a non-real number (we'll look into this at the end of the chapter), and therefore it doesn't fit anywhere into the hierarchy we currently have. $\sqrt{-1}$ is called an imaginary number. This is because there is no real number you can square to get -1 . Imaginary numbers, together with real numbers, e.g. $3 + 2 \times \sqrt{-1}$, are called complex numbers (complex because they are a complex of real and imaginary numbers – think of a housing complex made up of different parts).

Some more symbols

It is very wordy to say and write the following:

- the set of integers is a subset of the rational numbers
- 49 is an element of the set of counting numbers

We can shorten this by writing the symbols for the sets:

- \mathbb{Z} is a subset of \mathbb{Q}
- 49 is an element of \mathbb{N}_0

We can shorten this even more with symbol ' \subseteq ' for 'is a subset of' and the symbol ' \in ' for 'is an element of':

- $\mathbb{Z} \subseteq \mathbb{Q}$
- $49 \in \mathbb{N}_0$

Sometimes we also need to say that a number is *not* an element of a particular set. We use the symbol \notin for this $4,9 \notin \mathbb{Z}$.

Exercises

- 1 Rewrite all the statements listed in the previous two examples in short form using the symbols for sets and the symbols \subseteq , \in , and \notin .
- 2 Classify the following numbers:
 - (a) $-12\,584$
 - (b) $-36,36$
 - (c) $\sqrt{\frac{4}{5}}$
 - (d) $1,111\,1\dots$ (recurring)
 - (e) $4 \div 3$
 - (f) $4 \times \sqrt{3}$
 - (g) $\sqrt{4 \times 3}$
 - (h) $\sqrt{4}$
 - (i) $1 + \frac{2}{3}$
 - (j) $\sqrt{169}$
 - (k) $1 + \frac{1}{2} + \frac{1}{3} + \frac{1}{4} + \frac{1}{5}$
 - (l) $\sqrt{7} \times \sqrt{7}$
 - (m) $\sqrt{7} + \sqrt{7}$
 - (n) $\sqrt[3]{-1}$
 - (o) π
 - (p) circumference of a circle with radius 5
 - (q) the area of a square with sides $\sqrt{13}$
 - (r) the volume of a cube with sides $\sqrt{13}$

Real number line: the real numbers as a set of points

Describing real numbers as a set is useful but it is not very helpful. We need a way to represent that the set of all the real numbers is an **ordered set**, because if we compare any two numbers, one will always be bigger than the other.

Your class can be made into an ordered set by arranging all the learners alphabetically. This can also be done differently, e.g. by date and time of birth, by shoe size, by weight etc. Number sets are usually only ordered according to their values.

The way we do this is to imagine that each and every real number is a *point* on a line, called the **number line**. We show the order of numbers by putting smaller numbers to the left of bigger ones. Exactly like your ruler works.

You should be familiar with this representation of real numbers, but here it is again:



We can say that a continuous line is just many, many points very, very close to each other. We can pick out points to represent numbers. We always show the position of at least two numbers, usually 0 and 1. This allows us to orientate ourselves and also gives us the scale.

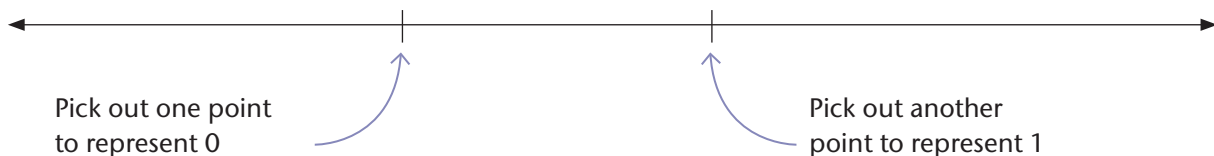

Now we can pick as many points as we wish from the line to represent other numbers. We need to do this carefully if we are *constructing* a number line. We need to measure where the point that we need to pick is.

Example Represent the number $\frac{4}{5}$ on a scaled number line

If we want to represent the number $\frac{4}{5}$, or four fifths, on our number line, we will have to measure $\frac{4}{5}$ or 0,8 of the distance between 0 and 1.

Step 1:

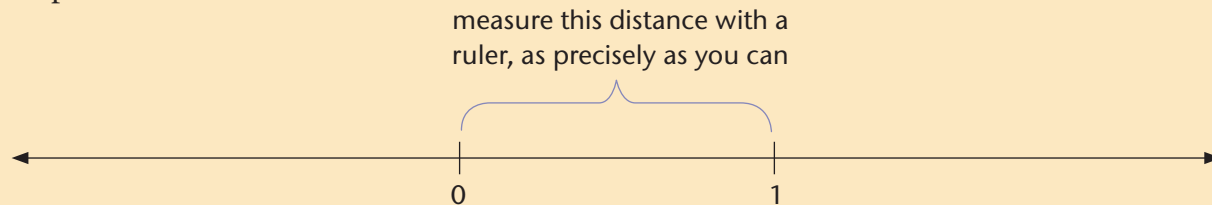

Step 2: Multiply the distance by $\frac{4}{5}$ (or 0,8).

Step 3: Measure the distance you get in Step 2, from zero.

This will give you the position of $\frac{4}{5}$. Actually, only very close to the correct position. How close depends on how precise you are with your measurements:

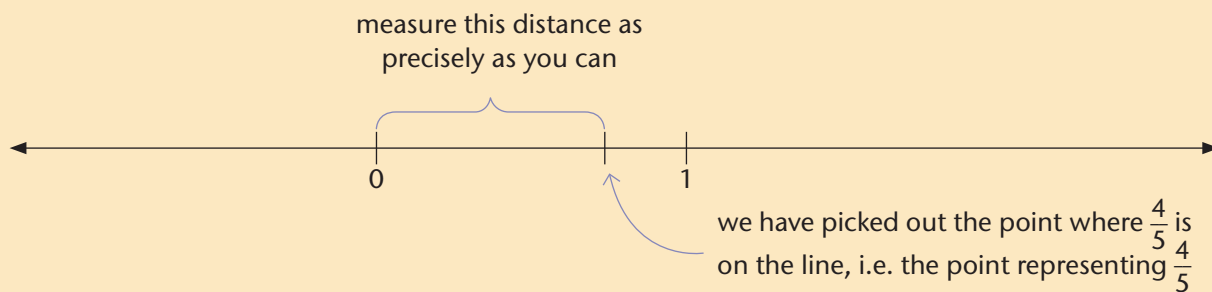

Exercises

3 You will now practice how to construct a number line. Choose a scale that is easy to use, e.g. the one on your ruler.

(a) Rule a line, choose a scale, and represent all the integers from -10 to 10 .

(b) Represent the following numbers on your number line:

3,75	π	$-\frac{33}{7}$	1,1
$\sqrt[3]{90}$	$8\frac{1}{9}$	4,48	1,01

Important: Round off your measurements to the nearest millimetre .

4 Decide which set the following values will belong to. Mention all the possible sets according to the set hierarchy:

(a) the heights of you and all your classmates measured to the nearest half centimetre

(b) the number of bread rolls in a packet

- (c) the length of the diagonal of a square with sides of length 1 m, to the nearest millimetre
- (d) the length of the diagonal of a square with sides *exactly* 1 m long, calculated using the Pythagorean Theorem, without your calculator.

Hint: in (c) you are rounding off an irrational number to three decimal places, but in (d) you are asked to give/describe the exact mathematical value of the length of the diagonal.

- (e) the areas of all squares with sides that are positive integer lengths
- (f) the areas of all squares that have lengths that are an integer and a half:
e.g. side length = 1,5 units, 2,5 units, 3,5 units
- (g) the cube root of a negative perfect cube
- (h) the length of the sides of a cube that has a volume of 10 cubic units.

2.2 More about how to represent sets and intervals

Sometimes we need to show other sets of numbers and not just the ones in the hierarchy, for example, to represent a list of numbers.

Notation: to show a set of numbers, we list them in increasing order in braces – curly brackets: { and }.

Example The set of possible results when you roll a die

Rolling a die will give you one of six possible results. We can show this as the following set: {1; 2; 3; 4; 5; 6} this is a way of representing the set made up of the numbers from 1 to 6. We could shorten this as follows: {1; 2; 3; ...; 6}. The ‘...’ in the set means ‘continue the pattern’.

Although this is not so useful for only six numbers, you can see that it is very useful if there are many numbers.

Definitions and more set notation

Set: a collection of numbers; each number is called an element of the set:

$\mathbb{R}, \mathbb{Z}; \{-1; 0; 1\}, \{1; \frac{1}{2}; \frac{1}{4}; \frac{1}{8}\}$ etc. are all sets.

Element: any one of the numbers in a set; we show that a number is an element of a set by writing $2 \in \mathbb{Z}$ and that it is not, by writing $\sqrt{2} \notin \mathbb{Z}$ (we say that 2 ‘is an element of’ the integers and that $\sqrt{2}$ ‘is not an element of’ the integers).

Cardinality: the number of elements in a set; all the sets in our hierarchy have an infinite cardinality except the set for zero, which we can represent as {0} and which has a cardinality of 1; the sets in our example above has a cardinality of 6. The set of rational numbers between 0 and 1 are infinite because there is no limit to how many you can count.

Subset: a set that has some of the elements of another set in it, for instance, the integers are a subset of the rational numbers and the set in our example is a subset of the natural numbers. We have seen that we can write these as $\mathbb{Z} \subseteq \mathbb{Q}$ and $\{1; 2; 3; 4; 5; 6\} \subseteq \mathbb{N}$.

Interval: a subset of all the numbers between two given numbers called the end points. The set in our example is an interval in the integers.

There is special notation for intervals: $\{x \in \mathbb{Z} \mid 1 \leq x \leq 6\}$.

This is read as: {...} meaning ‘the set of ...’

$x \in \mathbb{Z}$ meaning ‘... all elements x in the set of integers ...’

\mid meaning ‘... such that...’

$1 \leq x \leq 6$ meaning ‘... x is between and including 1 to 6’

The set in our example could also be written as $\{x \in \mathbb{Z} \mid 0 < x < 7\}$ where $0 < x < 7$ means all the numbers between but *not* including 0 and 7.

Interval notation: the short version of this is to write $x \in [1; 6]$ for the first and $x \in (0; 7)$ for the second representation. $[$ and $]$ means include the end points of the interval while $($ and $)$ mean exclude the end points.

Number set notation and representing number sets on a number line

Example

Represent the set of all real numbers between -2,4 and 4,7, including 4,7

As an interval: $-2,4 < x \leq 4,7$, where $x \in \mathbb{R}$.

In set notation: $\{x \in \mathbb{R} \mid -2,4 < x \leq 4,7\}$

In interval notation: $(-2,4; 4,7]$ with real elements

On number lines

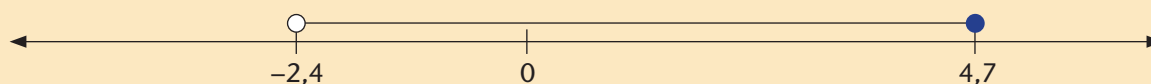

Example

Represent all the integers less than 100 but greater than or equal to 5

As an interval: $5 \leq x < 100$ or $5 \leq x \leq 99$ where $x \in \mathbb{Z}$

In set notation: $\{x \in \mathbb{Z} \mid 5 \leq x < 100\}$ or $\{x \in \mathbb{Z} \mid 5 \leq x \leq 99\}$

In interval notation: $[5; 100)$ or $[5; 99]$ with elements in \mathbb{Z}

We could also write $\{5; 6; \dots; 99\}$ here because we are able to list all the elements if we want to. We can't do that in the previous or the next example though!

On number lines (noting that we are dealing with integers):

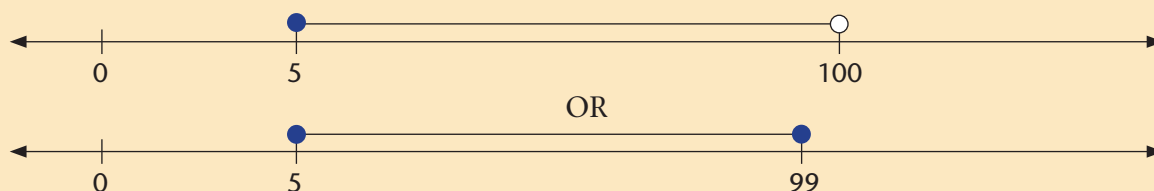

Example

Represent all the rational numbers greater than or equal to a ninth

As an interval: $x \geq \frac{1}{9}$ where $x \in \mathbb{Q}$

In set notation: $\{x \in \mathbb{Q} \mid x \geq \frac{1}{9}\}$

In interval notation: $[\frac{1}{9}; \infty)$ with elements in \mathbb{Q}

On number lines (noting that we are dealing with rational numbers):

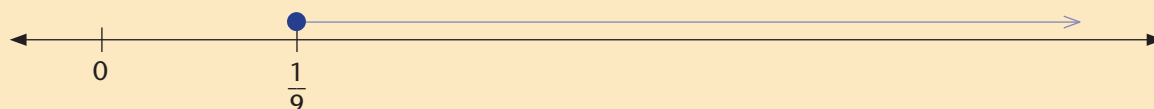

The symbol ∞ stands for **infinity**; there is no biggest real number, so we need to show that the interval continues to the right without reaching a cut-off. Notice that $($ is used and not $]$. The reason is that infinity is not normally treated as a number. We show this by 'excluding' it from the interval.

We don't show the upper end point on the number line in the last example because there is no upper end point (all the rational numbers greater than a ninth).

In all three of the examples, the number line representations above are not to scale. They are being used to represent the intervals without trying to be precise about the positions of the points on the line that represent 0 and the end points of the intervals.

Exercises

5 Explain in words what the following mean:

(a) $\{1,1; 1,2; \dots; 1,7\}$

(b) $x \in \mathbb{Z} \{-2 \leq x < 11\}$

(c) $y \in \left(\frac{1}{3}; \frac{4}{3}\right) \subseteq \mathbb{Q}$

(d) the real number line:

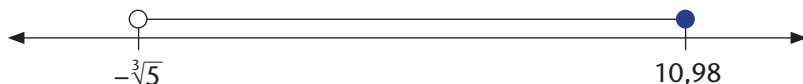

(e) $\{x \in \mathbb{N}_0 \mid x \in [500; 550]\}$

6 Represent the following sets in set notation:

(a) all real numbers between -10 and -5

(b) all the real numbers between -10 and -5 , including -5

(c) all real numbers between and including -10 and -5

(d) all integers smaller than 7

(e) all natural numbers smaller than 7

7 (a) Repeat question 6 but use interval notation.

(b) Repeat question 6 but represent it on the number line, not to scale.

8 Give the cardinality of each of the sets in question 5 and 6.

2.3 Rounding off and significant figures

This section is a short revision on rounding off. Work through this very quickly, and only if you need to!

When we round off, we are doing the following:

- expressing the number in decimal fraction form
- approximating its value by cutting off any decimal digits after a certain digit
- making sure the last digit of your rounded value gives the most accurate reflection of the values you have cut off

Note: Look ahead to the section on significant figures in Chapter 3 paragraph 3.6

Rounding off to a certain number of decimal places

How the rounded digit of a decimal number is determined by the rounding the decimal number:

Three decimal places	Rounded to two decimal places
1,224	1,22
1,225	1,23
1,226	1,23
1,229	1,23
1,230	1,23
1,234	1,23
1,235	1,24
1,236	1,24

Example

Rounding off 17,984 364 501 to different numbers of decimal places

Number of decimal places	Digit to determine round off – green; digit being rounded off – blue	Rounded off value; the rounded digit is in blue
Eight	17,984 364 5 01	17,984 364 5 0
Seven	17,984 364 5 01	17,984 364 5
Six	17,984 364 5 01	17,984 36 5
Five	17,984 3 64 501	17,984 3 6
Four	17,984 3 64 501	17,984 4
Three	17,9 8 4 364 501	17,9 8 4
Two	17,9 8 4 364 501	17,9 8
One	17,9 8 4 364 501	18, 0
Zero	17,9 8 4 364 501	1 8

As you check each of these, *always refer to the original number*. You cannot always use one rounded version of the number to get the next rounded version; look at the rounding off to five decimal places, shown in bold in the above table, to see how it can go wrong.

When we round off to a certain number of decimal places, we look at the digit just after the one we are rounding to. For example, if we need to round off to six decimal places, we look at the digit in the seventh decimal place and *nothing else*. If the seventh digit is 0, 1, 2, 3, or 4, we keep the sixth digit as it is. If the seventh digit is a 5, 6, 7, 8, or 9, then we increase the sixth digit by 1.

Exercises

9 Round off to the following decimal places:

(a) 22,891 452 784

(i) eight

(ii) seven

(iii) six

(iv) five

(b) 21,115 745 912

(i) four

(ii) three

(iii) two

(iv) one

(c) 58,453 451 671

(i) seven

(ii) two

(iii) one

(iv) zero

(**Hint:** rounding off to zero decimal places is the same thing as rounding off to the nearest whole number.)

2.4 Rational numbers in more detail

Rational numbers are useful because they can always be written as proper fractions.

Let us look at a number in decimal form, such as 26,24.

This is clearly $2\ 624 \div 100$. So, we can write it as the ratio i.e. a fraction of two whole numbers

2 624:100 or $\frac{2\ 624}{100}$. Therefore, it is a rational number.

We call a fraction that has a finite number of decimal digits a **terminating fraction**.

Any decimal number that terminates, i.e. ends, after a certain number of decimal digits is rational, even something ugly like 1,245 723 105 447 200 598 3 is rational.

To terminate, means to end. A work contract can be terminated if workmanship is poor or if there are big delays.

Measurements and rational numbers

We round off when a terminating rational fraction is too long or contains more information than we need. We are either shortening an existing rational decimal fraction or we are approximating an irrational number using a decimal fraction.

Example Buying wooden planks

Suppose you need wooden planks that are 3,58 m long. When you order the planks, you don't tell the supplier to cut the planks 3,58 m long. Rather, you ask for the planks to be cut longer, to 3,6 m, or even 3,7 m, or 3,8 m to be safe. 3,6 m is the value rounded upwards and 3,7 m or 3,8 m is the rounded value plus an extra length just to be sure the plank is long enough. You will cut off the ends so that the length is exactly 3,58 m.

Example Measuring the current in a circuit

When you connect an ammeter in a circuit it will only allow you to read off the current to a certain precision, say 0,1 A, or, on a more precise instrument, to 0,01 A. In general, any measurement you make will be a rounded off value and automatically also a rational number, even if the number you are measuring is irrational, see Exercise 4 (c) and (d).

Measurements are always rational

All the numbers you will actually measure and use in any of the technical fields have to be rational. You will just have to decide how many decimal places or significant figures you need to ensure that your rational numbers are not rounded off too much.

Your calculator and switching between decimal and rational forms of numbers

Your calculator can be set to give answers in rational form whenever possible or to give them in decimal form. Read your calculator instructions or ask your teacher to assist you.

Recurring or non-terminating decimal fractions

A **recurring fraction** is one where a series of digits repeats over and over again without end. All recurring decimal fractions are rational. It is not difficult to express such a decimal fraction as a rational fraction.

Worked example

The decimal fraction $12,14\dot{6}$... recurring as a rational fraction

Recurring decimals like this are also written as $12,14\dot{6}$. The dots indicate the bit that recurs.

We can show that such numbers are rational by a clever bit of arithmetic.

First, note that $12,14\dot{6} \times 1\,000 = 12\,146,14\dot{6}$

$$\text{So } 12,14\dot{6} \times 1\,000 - 12,14\dot{6} = 12\,146,14\dot{6} - 12,14\dot{6}$$

$$\text{So } 12,146 \times 999 = 12\,134 \quad \text{[recurring part cancels]}$$

$$\text{Thus } 12,146 = \frac{12\,134}{999}$$

We call a decimal fraction that has an infinite number of digits in its fractional part a **non-terminating**, i.e. non-ending, fraction. A third is a simple example of this since its decimal form is 0,333 ... recurring. Four ninths is 0,444 ... recurring. An eleventh is 0,090 9 ... recurring, etc.

Property: any number with a recurring (and non-terminating) decimal part is a rational number. Even something complex like $1,294\ 875\ 537\ 487\ 553\ 748\ 755\ 374\ \dots$ recurring = $1,294\ \dot{8}75\ 537\ \dot{4}$, is a rational number because the part 8755374 repeats over and over again after the 294 bit.

Property: If a fraction is non-terminating and non-recurring, it is an irrational number because it cannot be written as a ratio of two whole numbers.

Exercises

10 Write decimal fractions as rational fractions (using the preceding approaches).

- | | |
|----------------------------|---|
| (a) 0,16 | (b) $0,1\dot{6}$ |
| (c) $0,\dot{1}$ | (d) 0,125 |
| (e) $0,\dot{2}$ | (f) 0,062 5 |
| (g) $0,\dot{7}$ | (h) 5,125 |
| (i) 0,235 235 ...recurring | (j) 7,947 384 738 473 847 384 ... recurring |

We can also write any rational fraction as a decimal fraction. The decimal expression will either terminate or recur and not terminate.

Worked example

Problem: Writing $\frac{323}{12}$ as a decimal fraction

Solution 1: Grouping (or splitting)

$$\frac{323}{12} = \frac{312}{12} + \frac{11}{12}$$

$$= 26 + \frac{11}{12}$$

$$= 26 + \frac{108}{120} + \frac{2}{120}$$

$$= 26 + 0,9 + \frac{12}{1\ 200} + \frac{8}{1\ 200}$$

$$= 26,9 + 0,01 + \frac{72}{12\ 000} + \frac{8}{12\ 000}$$

$$= 26,91 + 0,006 + 0,000\ 6 + \dots$$

312 is the biggest multiple of 12 that is smaller than 323; 11 is the remainder

$\frac{11}{12} = \frac{110}{120}$ and 108 is the largest multiple of 12 that is less than 110; 2 is the remainder

$\frac{2}{120} = \frac{20}{1\ 200}$ and 12 is the largest multiple of 12 that is less than 20; 8 is the remainder

8 is the remainder again, so 6 must recur

Giving us 26,916 666 ... recurring

Solution 2: By long division

$$\begin{array}{r} 26,916,6\dots \\ 12 \overline{) 323} \\ \underline{240} \\ 83 \\ \underline{72} \\ 110 \\ \underline{108} \\ 020 \\ \underline{012} \\ 0080 \\ \underline{0072} \\ 00080 \\ \underline{00072} \\ 00008\dots \end{array}$$

Exercise

11 Write rational fractions as decimal fractions.

(a) $\frac{3}{9}$

(b) $4\frac{7}{8}$

(c) $\frac{2}{7}$

(d) $7\frac{8}{13}$

(e) $\frac{11}{16}$

(f) $\frac{452}{15}$

(g) $\frac{861}{11}$

(h) $9\frac{11}{12}$

(i) $\frac{1560}{33}$

(j) $\frac{23}{12}$

2.5 Irrational numbers in more detail

Irrational numbers cannot be written as ratios of *whole* numbers. There are three important places where irrational numbers occur in the Mathematics you are studying:

- in circles: π is an irrational number
- in surds
- in trigonometry: look ahead at Chapter 6; trigonometric functions usually convert rational input values to irrational output values.

Exercise

12 You will need your compass and a ruler.

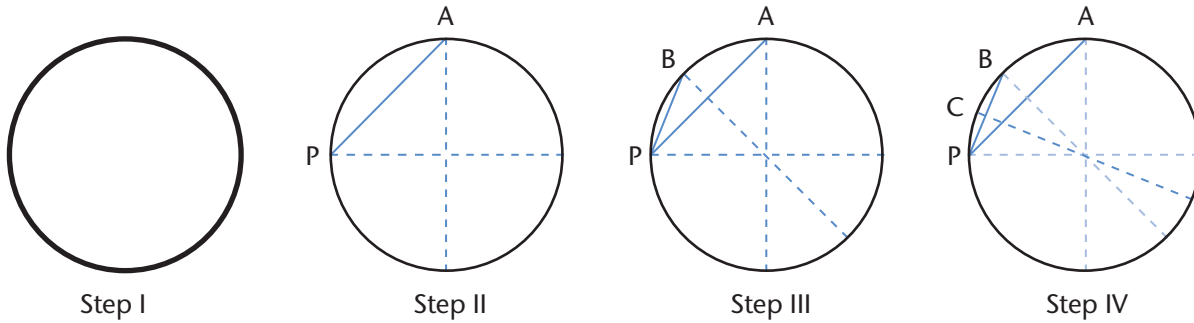

- (a) Do the following (each step shown above):
- (I) Draw a circle of radius 10 cm.
 - (II) Construct a pair of perpendicular diameters. Join P and A.
 - (III) Bisect PA. Construct the diameter passing through the midpoint of PA to the circle at B. Join P and B.
 - (IV) Repeat Step III for segment PB to get segment PC.
- (b) PA, PB, and PC are the sides of regular polygons. How many sides do the three polygons have? Name them where possible.
- (c) Redraw the following table in your exercise book and then complete the table. Diameter of the circle: $D = 20$ cm

Line segment forming one side of polygon	Polygon side lengths (in cm)	Number of sides of polygon N	Total polygon perimeter $C = s \times N$ (in cm)	$\frac{C}{D}$
PA				
PB				
PC				

- (d) Suppose you could repeat this process. Do you agree with the following statement?
 ‘This ratio is the same no matter how big or small the circle is. All circles are similar to each other. So π is a constant.’

What have you realized?

In Exercise 12, you determined three approximations of π .

- In Step I (PA), you approximated π very roughly using a square (you should have got $\frac{C}{D} = 2,83$).
- In Step II (PB), you approximated π less badly using an octagon (you should have got $\frac{C}{D} = 3,06$).
- In Step III (PC), you should get your best approximation of π (you should have got $\frac{C}{D} = 3,12$).

Do not be worried if you do not get the ratios very close to the ones given above. If you were very careful in your constructions and measurements, you should be close enough. What is more important is the *idea* that emerges.

You have to trust that two things will emerge:

- Each approximation has more decimal digits than before. This means that π is a non-terminating decimal fraction.
- There is no repeating pattern in the decimal digits. So π is a non-recurring decimal fraction.

Conclusion: This means that π has to be an irrational number.

The more sides the polygon has, the more like the circle it becomes. This means that the ratio of $C:D$ for a polygon with 32 sides, 64 sides, etc. will be closer and closer to the ratio $C:D$ of the circle.

You can calculate these ratios using the Pythagorean Theorem. It is a bit tricky, but if you feel like a challenge, you should try. We can get better and better approximations of π by constructing the sides of polygons with more and more sides.

Definition of π

π or π is defined as the ratio of the circumference of a circle to its diameter. In other words, $C = \pi \times D$ where C represents the circumference and D represents the diameter of the circle.

Note: We can write any two real numbers as a ratio. That π is a ratio does not mean that it must be rational. The point is that no matter how we try, $C \div D$ is an irrational number. We will never find that C and D are both rational if we could measure them with perfect accuracy.

Another way of approximating π

Here is an easy way to approximate π with a disc, e.g. an old CD:

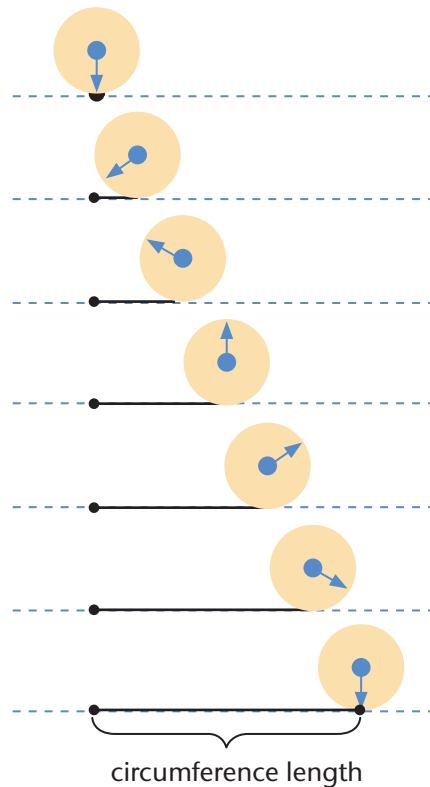

You have to be careful that the disc does not slip as you roll it. Very carefully, measure the rolled out circumference and the diameter to the nearest millimetre, then you should be able to calculate a pretty close value for π , correct to two decimal places at least.

Note: This approach does not really show us that π is irrational, but does give us an easy way to measure its value as best we can. The accuracy is improved when we use a very big disc and make sure that the surface is absolutely flat.

True surds are irrational numbers

Worked example

Problem: Approximating $\sqrt{2}$

In this exercise, you MAY NOT calculate $\sqrt{2}$ on your calculator.

Solution:

$\sqrt{2}$ lies between 1 and 2 because $1^2 = 1$ and $2^2 = 4$ and 2 is between 1 and 4.

$\sqrt{2}$ lies between 1,4 and 1,5 because $1,4^2 = 1,96$ and $1,5^2 = 2,25$

$\sqrt{2}$ lies between 1,41 and 1,42 because $1,41^2 = 1,9881$ and $1,42^2 = 2,0164$... and so on ...

Exercise

13 Now, use the same approach to do the following:

- Show that $\sqrt{2}$ lies between 1,414 and 1,415.
- Between which two decimals, rounded to four decimal places, does $\sqrt{2}$ lie?
- The same as in (b) but two numbers rounded off to five decimal places.
- Can you go on? Your calculator may not be able to keep up!
- Can you see any pattern in the decimal digits? Do you think the decimal form of $\sqrt{2}$ will terminate (end) at some point?
- Do you think the decimal digits of $\sqrt{2}$ will have a recurring pattern?

Two things will emerge from this investigation

- Each approximation pair has more decimal digits than before. This means that $\sqrt{2}$ is a non-terminating decimal fraction.
- There is no repeating pattern in the decimal digits of the approximation pairs, so $\sqrt{2}$ is a non-recurring decimal fraction.

Conclusion: This means that $\sqrt{2}$ must be an irrational number.

Note: Again, you have to take these two statements on trust. If you agree that they are believable, then you will find it easier to accept that they are, in fact, true.

Property: Any true surd is irrational, in other words, $\sqrt[n]{x}$ will be irrational whenever x is not a perfect n^{th} power.

Rational approximations of irrational numbers

When we write an irrational number such as π or $\sqrt{2}$, we are writing down a symbol that represents a number. If you try to write down the decimal value of irrational numbers, you will encounter a challenge of non-terminating, non-recurring numbers. There is no repeating pattern in the decimal fraction part of an irrational number. The best we can do is to write down the rounded off values.

Exercises

14 Use your calculator to answer the following:

- Write down the value of π
- Calculate the value of $22 \div 7$ and write down the full display showing on your calculator screen.
- Are the values in (a) and (b) the same? Explain.
- Which of the values in (a) and (b) is better for calculating the circumference and the area of a circle? Explain.

15 The following surds may be rational or irrational. If the surd is rational, give its value. If the surd is irrational, determine the two whole numbers it lies between. Do not use your calculator to calculate these directly.

- | | | |
|--------------------|---------------------|--------------------|
| (a) $\sqrt{3}$ | (b) $\sqrt{4}$ | (c) $\sqrt{5}$ |
| (d) $\sqrt{6}$ | (e) $\sqrt{7}$ | (f) $\sqrt{8}$ |
| (g) $\sqrt{9}$ | (h) $\sqrt{10}$ | (i) $\sqrt{15}$ |
| (j) $\sqrt{25}$ | (k) $\sqrt[3]{7}$ | (l) $\sqrt[3]{8}$ |
| (m) $\sqrt[3]{9}$ | (n) $\sqrt[3]{25}$ | (o) $\sqrt[3]{70}$ |
| (p) $\sqrt[4]{70}$ | (q) $\sqrt[4]{320}$ | (r) $\sqrt[5]{41}$ |

16 Determine the values of the true surds in Exercise 15 using your calculator.

Do you agree with the following statement? ‘The rounded off values we just calculated are rational approximations of irrational numbers. Therefore, these are not the actual complete values of the surds, which we cannot write down because they are infinitely long’.

2.6 Binary numbers

Binary numbers are at the heart of how electronic computers work. Your calculator, your cell phone, and your tablet are all just very complex machines using binary numbers. Computers use the binary number system to manipulate and store all of their data including numbers, words, videos, graphics, and music. Those of you who will do electronics will learn more about how this works.

We are used to decimal numbers. We are so familiar with them that we may not see that there are other ways of representing numbers.

In the decimal number system, numbers are made up of place values that are based on powers of 10. The number 125 602,12 is represented in the table below:

Hundred thousands	Ten thousands	Thousands	Hundreds	Tens	Units		Tenth	Hundredth
10^5	10^4	10^3	10^2	10^1	100	,	10^{-1}	10^{-2}
100 000	10 000	1 000	100	10	1	,	$\frac{1}{10}$	$\frac{1}{100}$
1	2	5	6	0	2	,	1	2

This decimal number 125 632,12 is interpreted and understood in terms of the place value of the individual digits:

$$125\,632,12 = (1 \times 10^5) + (2 \times 10^4) + (5 \times 10^3) + (6 \times 10^2) + (0 \times 10^1) + (2 \times 10^0) + (1 \times 10^{-1}) + (2 \times 10^{-2})$$

This may look strange, but remember how decimal numbers are written:

100 000	10 000	1 000	100	10	1
0	0	2	0	1	6

This is shortened to 2 016, which means 2 thousands, 0 hundreds, 1 tens and 6 units.

In a similar way, in the binary number system, a binary number is made up of place values of individual digits (0 or 1) that are based on powers of base 2. **Binary numbers** are represented in powers of 2 (like 'deci-' has to do with 10, 'bi-' has to do with 2). The table below shows the individual place values of a 9 digit binary number 100100011:

Two-Hundred-Fifty-Sixes	Hundred-Twenty-Eights	Sixty-Fours	Thirty-Twos	Sixteens	Eights	Fours	Twos	Ones
2^8	2^7	2^6	2^5	2^4	2^3	2^2	2^1	2^0
256	128	64	32	16	8	4	2	1
1	0	0	1	0	0	0	1	1

Binary numbers are numbers in the base 2. To express a decimal number in binary form we decompose the decimal number into the sum of powers of base 2. The binary number is then made up of 0 and 1 in positions with specific place values that are powers of base 2.

Converting decimal to binary

Converting the decimal number 291 to a binary number, we start by decomposing 291 into powers of base 2:

$$291 = 256 + 32 + 2 + 1 = (1 \times 2^8) + (1 \times 2^5) + (1 \times 2^1) + (1 \times 2^0)$$

To convert 291 into a binary number, all place value digits must be accounted for:

$$291 = (1 \times 2^8) + (0 \times 2^7) + (0 \times 2^6) + (1 \times 2^5) + (0 \times 2^4) + (0 \times 2^3) + (0 \times 2^2) + (1 \times 2^1) + (1 \times 2^0)$$

So, 291 as a binary number will be 100100011.

Converting binary to decimal

Let us now convert the binary number 100111011 to a decimal number.

Two-Hundred-Fifty-Sixes	Hundred-Twenty-Eights	Sixty-Fours	Thirty-Twos	Sixteens	Eights	Fours	Twos	Ones
2^8	2^7	2^6	2^5	2^4	2^3	2^2	2^1	2^0
256	128	64	32	16	8	4	2	1
1	0	0	1	1	1	0	1	1

From the table above, the binary number 100111011 can be converted to a decimal number by calculating the sum of the products of each digit (0 or 1) and the actual place value of the position of the digit.

So, the binary number 100111011 converted to decimal is:

$$\begin{aligned} &= (1 \times 2^8) + (0 \times 2^7) + (0 \times 2^6) + (1 \times 2^5) + (1 \times 2^4) + (1 \times 2^3) + (0 \times 2^2) + (1 \times 2^1) + (1 \times 2^0) \\ &= 256 + 0 + 0 + 32 + 16 + 8 + 0 + 2 + 1 \\ &= 315 \end{aligned}$$

One convention of binary notation is that a binary number is written with a subscript 2 after the last digit on the right: 100111011_2 .

We can express any real number in binary form. However, we will mostly look into expressing integers to binary.

There are two different ways to express decimal numbers in binary form, both are based on the above conversion. You will have to try this by yourself and take some time to practise this.

Worked examples

A. Problem: Express the decimal number 83 in binary form.

Solution 1: Begin by writing down all the powers of 2 that are smaller than 83:

$$2^6, 2^5, 2^4, 2^3, 2^2, 2^1, 2^0$$

$$64, 32, 16, 8, 4, 2, 1$$

Starting with 64, which is the highest power of 2 that is less than 83, write 83 as the sum of powers of two, without repeats:

$$\begin{aligned} 83 &= 64 + 19 \\ &= 64 + 16 + 3 \\ &= 64 + 16 + 2 + 1 \end{aligned}$$

We are splitting 83 into parts that are powers of 2, *without repeating any of them*.

We can show this in a table as follows:

Hundred-Twenty-Eights	Sixty-Fours	Thirty-Twos	Sixteens	Eights	Fours	Twos	Ones
2^7	2^6	2^5	2^4	2^3	2^2	2^1	2^0
128	64	32	16	8	4	2	1
0	1	0	1	0	0	1	1

Therefore, the decimal number 83 converted to a binary number is 1010011_2 .

We read the number as ‘one-zero-one-zero-zero-one-one’, and *not* as we would a decimal number with the same digits.

Solution 2: Converting 83 to a binary number – repeated division by 2

2	83	
2	41	remainder 1
2	20	remainder 1
2	10	remainder 0
2	5	remainder 0
2	2	remainder 1
2	1	remainder 0
	0	remainder 1

Therefore, $83 = 1010011_2$

B. Problem: Write the decimal number 187 in binary form.

Solution 1:

Step 1: Write down all the powers of two smaller than 187.

$$2^7, 2^6, 2^5, 2^4, 2^3, 2^2, 2^1, 2^0$$

$$128, 64, 32, 16, 8, 4, 2, 1$$

Step 2: Starting with 128, write 187 as the sum of the powers of two, without repeats

$$187 = 128 + 59$$

$$= 128 + 32 + 27$$

$$= 128 + 32 + 16 + 11$$

$$= 128 + 32 + 16 + 8 + 3$$

$$= 128 + 32 + 16 + 8 + 2 + 1$$

Step 3: We can represent this on the table as shown below. For every existing power of two above, the value will be one. Otherwise, use zero:

Hundred-Twenty-Eights	Sixty-Fours	Thirty-Twos	Sixteens	Eights	Fours	Twos	Ones
2^7	2^6	2^5	2^4	2^3	2^2	2^1	2^0
128	64	32	16	8	4	2	1
1	0	1	1	1	0	1	1

The binary number representing 187 is 10111011_2 .

Solution 2: Converting 187 to a binary number – repeated division by 2

2	187	
2	93	Remainder 1
2	46	Remainder 1
2	23	Remainder 0
2	11	Remainder 1
2	5	Remainder 1
2	2	Remainder 1
2	1	Remainder 0
	0	Remainder 1

Therefore, $187 = 10111011_2$

Why does binary only need the two digits 0 and 1?

Unlike decimal numbers, which use the ten digits 0 to 9, binary numbers only need two digits, 0 and 1. This is because if you have, say, two 16's, then you have one 32. So, there is no need for any more digits in binary representations.

Worked example Convert binary to decimal

Problem: Convert the binary number 110100010_2 to its decimal form.

Solution: Begin by counting the number of digits in the binary number. There are nine.

256	128	64	32	16	8	4	2	1
1	1	0	1	0	0	0	1	0

- Write down the first nine powers of 2, including 1 for the units.
- Place 1 and 0 in their correct positions.
- Now, write down the sum of the powers of 2 and add them to get the decimal form:
 $256 + 128 + 32 + 2 = 418$

Exercises

17 Counting in binary. The numbers 1 to 5 in binary are as follows:

1, 10, 11, 100, 101

- (a) Check that these are correct by converting them to decimal form.
- (b) Write down the next fifteen numbers up to, and including twenty, in binary form.

18 Express the following binary numbers in decimal form:

- | | |
|-------------|-------------|
| (a) 1 | (b) 11 |
| (c) 111 | (d) 1111 |
| (e) 10 | (f) 110 |
| (g) 1110 | (h) 101 |
| (i) 1001 | (j) 10001 |
| (k) 1010001 | (l) 1000110 |
| (m) 1111111 | (n) 1110111 |

19 Express the following decimal numbers in binary form:

- | | | |
|---------|---------|--------------|
| (a) 111 | (b) 112 | (c) 113 |
| (d) 127 | (e) 129 | (f) 365 |
| (g) 10 | (h) 100 | (i) 1 000 |
| (j) 384 | (k) 484 | (l) 385 |
| (m) 500 | (n) 623 | (o) your age |
- (p) number of learners in your Mathematics class
- (q) number of learners in your school

20 Which binary number is bigger? Explain your reasoning.

- | | |
|----------------------|------------------------|
| (a) 11111 or 11110 | (b) 11111 or 100000 |
| (c) 10101 or 10010 | (d) 110010 or 110100 |
| (e) 101010 or 101101 | (f) 1001011 or 1010101 |

Adding and subtracting binary numbers

The arithmetic of binary numbers is similar to that of decimals. We can follow the same procedures, as long as we remember that our base is 2 and not 10.

Note: Make sure when you do column addition that you keep the weight of the units in mind. If you are unsure, go back to the table at the start of this section.

Exercises

21 Add the following powers of two (we are working with decimal numbers here):

- | | |
|---------------|-----------------|
| (a) $1 + 1$ | (b) $2 + 2$ |
| (c) $4 + 4$ | (d) $8 + 8$ |
| (e) $16 + 16$ | (f) $32 + 32$ |
| (g) $64 + 64$ | (h) $128 + 128$ |
- (i) What do you notice? Complete this sentence:
When we add a power of 2 to itself, we get ...

22 Repeat the calculations in Exercise 21 (a) – (h), but for the numbers in binary form, e.g. $4 + 4 = 8$ becomes $100 + 100 = 1000$.

Write down a rule for yourself about what you notice.

Worked example Addition

Problem: Add the binary numbers 111 and 101:

Solution 1: Grouping

$$\begin{aligned}
 111 + 101 &= (100 + 10 + 1) + (100 + 1) \\
 &= (100 + 100) + 10 + (1 + 1) \\
 &= 1000 + 10 + 10 \\
 &= 1000 + 100 \\
 &= 1100
 \end{aligned}$$

Solution 2: Column addition

	+ ¹	1 ⁺¹	1 ⁺¹	1	
+	1	1	0	1	
<hr style="width: 100%;"/>					
	1	1	0	0	

1 + 1 + 1 = 11; write 1 in the fours column and 'carry' 1 to the eights column

1 + 1 = 10; write 0 in the unit column and 'carry' 1 to the twos column

1 + 1 + 0 = 10; write 0 in the twos column and 'carry' 1 to the fours column

Exercises

23 Add the following binary numbers:

- (a) $1 + 10$ (b) $100 + 1$ (c) $100 + 10$
(d) $100 + 11$ (e) $101 + 10$ (f) $1000 + 111$
(g) $1000 + 100 + 11$ (h) $1000 + 100 + 10 + 1$

Write down a few rules for yourself based on what you notice here.

24 Add the binary numbers. Use grouping and column addition in each case. You can check your answers by redoing the calculations in decimal form (first convert the numbers).

- (a) $11 + 10$ (b) $11 + 11$ (c) $101 + 101$
(d) $111 + 111$ (e) $1011 + 1110$ (f) $1101 + 1010$
(g) $10111 + 1111$ (h) $11010 + 1110$ (i) $10001 + 11111$
(j) $101010 + 110011$ (k) $11 + 1$ (l) $111 + 1$
(m) $110 + 10$ (n) $1100 + 100$ (o) $11111 + 1$
(p) $11111 + 10$ (q) $11111 + 100$ (r) $11111 + 1000$

Worked example What about subtraction?

Problem: Subtract the binary numbers: $110 - 101$

Solution:

Method 1:

Column subtraction

$$\begin{array}{r} 1\ 1\ 0^1 \\ - 1\ 0\ 1 \\ \hline 0\ 0\ 1 \end{array}$$

Method 2: Grouping

$$\begin{aligned} 110 - 101 &= (100 + 10) - (100 + 1) \\ &= 10 - 1 \\ &= (1 + 1) - 1 \\ &= 1 \end{aligned}$$

In the units (2^0) column we have $0 - 1$. So we take 1 from the two's (2^1) column. This leaves 0 in the two's (2^1) column and 10 in the units column. $10 - 1 = 1$ etc.

Worked example

Problem: Subtract the binary numbers $1011 - 111$, using grouping.

Solution:

Method 1:

Column subtraction

$$\begin{array}{r} 1\ 0\ 1\ 1 \\ - 1\ 1\ 1 \\ \hline 1\ 0\ 0 \end{array}$$

Method 2: Grouping

$$\begin{aligned} 1011 - 111 &= (1\ 000 + 10 + 1) - (100 + 10 + 1) \\ &= 1\ 000 + 10 + 1 - 100 - 10 - 1 \\ &= 1\ 000 - 100 \\ &= 100 \end{aligned}$$

What if we have a smaller number minus a bigger one? What do you do when you work out a decimal difference like $17 - 23$ in your head? You work out $23 - 17 = 6$ and then you know that $17 - 23 = -6$. Do the same for binary numbers. Negative binary numbers make the same sense as negative decimal numbers.

Exercise

25 Do the following binary subtractions. Be aware that in some cases a bigger binary number is subtracted from a smaller one. Check your answers by redoing the calculations in decimal form.

- | | |
|---------------------|-----------------------|
| (a) $11 - 10$ | (b) $10 - 11$ |
| (c) $111 - 101$ | (d) $111 - 100$ |
| (e) $1110 - 1011$ | (f) $1101 - 1010$ |
| (g) $10111 - 1111$ | (h) $11010 - 1110$ |
| (i) $11111 - 10001$ | (j) $110011 - 101010$ |
| (k) $11 - 1$ | (l) $111 - 1$ |
| (m) $110 - 10$ | (n) $1100 - 100$ |
| (o) $11111 - 1$ | (p) $11111 - 10$ |
| (q) $11111 - 100$ | (r) $11111 - 1000$ |

Multiplying binary numbers

Exercise

26 Copy and complete the following table and answer the questions that follow:

Multiplication in binary	Same multiplication in decimal	Result in decimal	Result in binary
11×10	3×2	6	110
101×10		10	
111×10			
1101001×10			
11×100			
101×100			
111×1000			

- (a) What do you realise about multiplying by 10, 100, 1000 etc. in binary?
- (b) Try to explain this by comparing the binary multiplication 110×10 with the decimal multiplication 284×10 .

Again, we can re-interpret the ways we do this in decimals.

Worked example

Problem: Multiply 111 and 101

Solution 1: Distributing and adding through grouping

$$\begin{aligned}111 \times 101 &= 111 \times (100 + 1) \\ &= 111 \times 100 + 111 \times 1 \\ &= 11100 + 111 \\ &= 11100 + 100 + 11 \\ &= (11100 + 100) + 11 \\ &= 100000 + 11 \\ &= 100011\end{aligned}$$

You see that $11100 + 100$ has been done in one step. If you are confused, refer to the last eight exercises you just completed. You may prefer to do $11100 + 100$ by grouping (which is not difficult, it just requires more writing out):

$$\begin{aligned}11100 + 100 &= 10000 + 1000 + 100 + 100 \\ &= 10000 + 1000 + 1000 \\ &= 10000 + 10000 \\ &= 100000\end{aligned}$$

Therefore $11100 + 100$ is equal to 100000

Solution 2: Column multiplication

$$\begin{array}{r} \\ \times \\ \hline \\ \\ \hline \end{array}$$

This is 111×1 (the 1 from 101)

This is 111×00 (the 0 from 101)

This is 111×100 (the 1 from 101)

Exercise

27 Do the following multiplications in binary. Check your answers by redoing the multiplications in decimal form.

- | | | |
|--------------------------|---------------------------|----------------------------|
| (a) 11×11 | (b) 110×11 | (c) 110×110 |
| (d) 101×11 | (e) 10×100 | (f) 11×111 |
| (g) 1101×101 | (h) 111×111 | (i) 1101×111 |
| (j) 1001×111 | (k) 1110×1011 | (l) 1001×1101 |
| (m) 10111×1101 | (n) 11001×1001 | (o) 101×111111 |
| (p) 111111×1001 | (q) 101101×11101 | (r) 110011×101111 |

Dividing binary numbers

Let us review decimal long division: $13 \div 2$

$$\begin{array}{r} 67 \\ 2 \overline{) 134} \\ \underline{- 12} \\ 14 \\ \underline{- 14} \\ 0 \end{array}$$

-- Therefore $134 \div 2 = 67$ remainder 0

Binary long division: $11011_2 \div 10_2$

$$\begin{array}{r} 1101_2 \\ 10_2 \overline{) 11011_2} \\ \underline{- 10} \\ 10_2 \\ \underline{- 10} \\ 011_2 \\ \underline{- 10} \\ 10_2 \end{array}$$

1_2 Therefore $11011_2 \div 10_2 = 1101_2$ remainder 1_2

Worked example

Problem: Calculate $10001_2 \div 101_2$

Solution 1: Long division the standard way

carry the 1 from the sixteens column to the eights column; this gives 10 in the eights column

carry 1 from the eights column to the fours column; this leaves 1 in the eights column

$$\begin{array}{r} 11_2 \\ 101_2 \overline{) 10001_2} \\ \underline{- 101} \\ 0111_2 \\ \underline{- 101} \\ 10_2 \end{array}$$

Therefore $10001_2 \div 101_2 = 11_2$ remainder 10_2

Solution 2: Grouping again

$$\begin{aligned}10001_2 &= 101_2 \times 10_2 + 111_2 \\ &= 101_2 \times 10_2 + 101_2 \times 1_2 + 10_2 \\ &= 101_2 \times (10_2 + 1_2) + 10_2 \\ &= 101_2 \times 11_2 + 10_2\end{aligned}$$

From the grouping above of the number 10001_2 to being equal to $101_2 \times 11_2 + 10_2$ we deduce that $10001_2 \div 101_2 = 11_2$ with remainder 10_2 .

Exercise

28 Use long division method to calculate the following binary numbers.

- | | |
|-----------------------|------------------------|
| (a) $100 \div 10$ | (b) $100100 \div 100$ |
| (c) $101 \div 10$ | (d) $10 \div 10$ |
| (e) $1111 \div 11$ | (f) $1111 \div 10$ |
| (g) $1111 \div 110$ | (h) $1111 \div 101$ |
| (i) $10110 \div 10$ | (j) $11000 \div 110$ |
| (k) $11001 \div 111$ | (l) $111111 \div 1001$ |
| (m) $111111 \div 110$ | |

OPTIONAL: Fractions in decimal form

Any real number can be expressed in binary form, including fractions. Instead of the decimal tenths, hundredths, thousandths, etc., in binary we have halves, quarters, eighths, sixteenths etc. So, e.g. 0,5 in decimal will be 0,1 in binary; 0,25 in decimal will be 0,01 in binary; and 0,75 in decimal will be 0,11 in binary. Other fractions are more challenging to convert, e.g. 0,333 ... recurring in decimal is 0,01010101 ... recurring in binary.

Worked example

Problem: Write the decimal number 5,375 in binary

Solution: You have to ‘see’ the fraction part as a sum of fractions that are powers of base 2.

Step 1: $5 = 4 + 1$, so 5 in binary is 101

Step 2A: Look for the biggest fraction less than 0,375 that is a power of two:

$$0,375 = 0,25 + 0,125 = \frac{1}{4} + \frac{1}{8}, \text{ so } 0,375 \text{ in binary is } 0,011$$

Step 2B: Alternative: using a series of steps (an algorithm):

Determine the smallest power of 2 that will multiply 0,375 to give you a product bigger or equal to 1:

2 is too small, but 4 works: $4 \times 0,375 = 1,5$. So, there is a quarter.

Repeat this step on the 0,5 i.e. $2 \times 0,5 = 1$. So, there is a quarter of a half.

Put these together: $0,375 = \frac{1}{4} + \frac{1}{4} \times \frac{1}{2} = \frac{1}{4} + \frac{1}{8}$, yielding 0,011 in binary.

Step 3: put the two parts together: 5,375 in decimal is 101,011 in binary.

Worked example Writing the binary fraction 0,1011 in decimal

Solution: Use a table as we did for whole numbers, but using fraction powers of base 2:

$\frac{1}{2}$	$\frac{1}{4}$	$\frac{1}{8}$	$\frac{1}{16}$	$\frac{1}{32}$	$\frac{1}{64}$...
2^{-1}	2^{-2}	2^{-3}	2^{-4}	2^{-5}	2^{-6}	...
1	0	1	1	0	0	...

So 0,1011 in binary is $\frac{1}{2} + \frac{1}{8} + \frac{1}{16} = 0,5 + 0,125 + 0,00625 = 0,6875$.

Note: In computer work, another base besides base 2 is also used. It is called the hexadecimal base, or base 16. Since we need 16 digits for it, and we only have 10 from the decimal system, the decimal numbers 10, 11, ... 15 are represented by A, B, ... , F. So, in hexadecimal the first twenty counting numbers are 0, 1, 2, 3, 4, 5, 6, 7, 8, 9, A, B, C, D, E, F, 10, 11, 12, 13, and 14. The number 2B7 in hexadecimal is $(2 \times 16^2) + (11 \times 16^1) + (7 \times 16^0) = 695$ in decimal.

Note: Fractions of angles and time are partially measured in sexagesimal base, i.e. base 60. A minute is one sixtieth of a degree or an hour. A second is one three-thousand-six-hundredth of a degree or hour. Look ahead to Chapter 10 for sexagesimal angles!

2.7 Complex numbers

Complex numbers are numbers that consist of real numbers and imaginary numbers. Complex numbers are denoted by C . They are in the form of $a + ib$, where a represents a real number and b represents imaginary numbers. Examples of complex numbers are $2 + 3i$, $-4 + i$, etc. Imaginary numbers can be written in terms of $\sqrt{-1}$. We use the symbol i for $\sqrt{-1}$. The arithmetic of imaginary numbers is therefore based on the following:

Property of i : $i^2 = i \times i = -1$

Therefore, $\sqrt{-1} = \sqrt{i^2} = i$

Exercises

29 Determine whether the following numbers are real or imaginary. Explain how you do this.

(a) $\sqrt{-2}$

(b) $\sqrt[3]{-1}$

(c) $\sqrt{-4}$

(d) $\sqrt[3]{-4}$

(e) $i + i$

(f) $-i \times -i$

(g) $i \times i \times i$

(h) $i \times i \times -i \times -i$

(i) $2i \times 3i$

(j) $i - i$

30 Simplify question 29 (a) to (j).

For enrichment: complex numbers can be added, subtracted, divided, and multiplied, e.g.

• $2 + 3i + (4 + 4i) = 6 + 7i$

• $-2 + i - 3i + 5 = 3 - 2i$

• $(2 + 3i)(-1 + 3i) = -2 + 6i - 3i + 9i^2 = -2 + 6i - 3i - 9 = -11 + 3i$

• $\frac{-4 + 6i}{2} = -2 + 3i$

2.8 Summary

- **Real numbers** are all the numbers we normally deal with. They are classified into sets in a hierarchical structure. The most important of these sets have special symbols.
- Real numbers can be represented on a **number line** by imagining each real number as a point on a scaled line. We also represent sets of numbers using set notation and interval notation.
- We **round off** numbers to remove unnecessary precision in the value. Every number we actually measure and use in our day-to-day work is actually rounded off because the measuring instruments we use are not able to give us perfectly precise readings.
- **Rational numbers** can always be written as proper fractions. Any decimal number that terminates after a certain number of decimal digits is rational. Any number with a recurring and non-terminating decimal part is a rational number. We round off irrational numbers to rational approximations. In effect, this means that the numbers we actually work with every day are always rational.
- A fraction that is non-terminating and non-recurring is an **irrational number** because it cannot be written as a ratio of two whole numbers. Three important places where irrational numbers occur in mathematics are in circles (π), in surds, and in trigonometry.
- **Binary numbers** are at the heart of how electronic computers work. Binary numbers are numbers in the base 2. This means that binary numbers only need two digits, 0 and 1. To express a whole number in binary form, we split it up in terms that are powers of base 2. We start with the highest power of 2 that is less than the number and work our way down to 1. Addition, subtraction, multiplication, and division can be done using the same ideas that we do for decimal arithmetic.
- **Imaginary numbers** are numbers that can be written in terms of $\sqrt{-1}$. We symbolise the number $\sqrt{-1}$ with the letter i . The arithmetic of imaginary numbers is based on the following property of i : $i \times i = -1$. Real numbers and imaginary numbers cannot be added directly. We call numbers that have a real part and an imaginary part complex numbers.

2.9 Consolidation exercises

1 Classify the following numbers.

(a) $-11\ 456$

(b) $-11,456$

(c) $\sqrt{\frac{4}{5}}$

(d) $3,333 \dots$ (recurring)

(e) $2 \div 3$

(f) $1 + \frac{1}{4} + \frac{3}{4}$

(g) $\sqrt{-5}$

(h) $\sqrt[3]{-5}$

2 Represent the following numbers on the same number line. Your number line does not have to be to scale.

(a) π

(b) $3,14$

(c) $\frac{22}{7}$

(d) $\frac{355}{113}$

Which of the rational numbers in (b), (c), and (d) is the best approximation of π ?

3 Write the following numbers in the simplest $\frac{\text{integer}}{\text{integer}}$ form possible:

(a) $0,75$

(b) $0,75\ 75 \dots$ recurring

(c) $0,025$

(d) $1,008$

(e) $4,38\ 38 \dots$ recurring

(f) $2\frac{3}{4}$

(g) $0,18$

(h) $0,12$ (2 recurring)

(i) $0,750$

(j) $3,125$

(k) $0,871\ 871 \dots$

(l) $2,23\ 23\ 23 \dots$

4 Write the following in decimal form:

(a) $\frac{6}{7}$

(b) $\frac{7}{8}$

(c) $\frac{8}{9}$

(d) $\frac{9}{10}$

(e) $\frac{35}{99}$

(f) $\frac{15}{990}$

(g) $\frac{2}{3}$

(h) $\frac{66}{990}$

(i) $\frac{11}{30}$

(j) $3\frac{6}{7}$

(k) $6\frac{7}{15}$

(l) $\frac{153}{44}$

5 Between which integers do the following surds lie?

(a) $\sqrt{5}$

(b) $\sqrt{11}$

(c) $\sqrt{31}$

(d) $\sqrt[3]{18}$

(e) $\sqrt[3]{41}$

(f) $\sqrt[5]{45}$

6 Write the numbers 1 to 25 in binary form.

7 Express the following binary numbers in decimal form.

- | | | |
|--------|---------|----------|
| (a) 1 | (b) 111 | (c) 11 |
| (d) 10 | (e) 110 | (f) 1001 |

8 Express the following decimal numbers in binary form.

- | | | |
|-----------|---------|--------|
| (a) 112 | (b) 45 | (c) 11 |
| (d) 1 589 | (e) 420 | (f) 13 |

9 Do the following binary calculations.

- | | |
|-------------------|------------------|
| (a) $1 + 111$ | (b) $1 + 10$ |
| (c) $10 + 110$ | (d) $10 + 111$ |
| (e) $101 + 1110$ | (f) $100 - 101$ |
| (g) $11 - 10$ | (h) $101 - 111$ |
| (i) $11011 - 111$ | (j) $11111 - 11$ |

10 Do the following binary calculations. In the case of division, give the remainder.

- | | |
|-----------------------|-----------------------|
| (a) 1×111 | (b) 1×10 |
| (c) 10×110 | (d) 10×111 |
| (e) 101×1110 | (f) $1010 \div 101$ |
| (g) $11 \div 10$ | (h) $111100 \div 100$ |
| (i) $11011 \div 111$ | (j) $11100 \div 100$ |

3 EXPONENTS

This chapter is mostly revision of what you did last year. We introduce this chapter with three technical applications. There are many more, some of which will reveal themselves in the exercise problems. In Grade 10, Exponents are all about repeated multiplication, repeated division, and counting factors. By repeated multiplication/division we mean multiplying/dividing by a particular number over and over.

In this chapter, you will:

- revise exponential notation, remembering that notation is how we *represent* something
- revise the properties of exponents, which are about how repeated multiplication works
- simplify expressions, which you need to be able to do for various reasons
- solve exponential equations, i.e. finding the value of an unknown exponent
- revise scientific notation, which you will need to do in technical sciences and in other technical subjects
- convert between squared units and converting between cubic units - a useful skill if you are doing measurements or solving real-life technical problems
- express values in different equivalent forms using prefixes such as kilo-, nano-, mega-, etc.
- identifying situations where exponents emerge - any situation that involves repeated multiplication is an exponential situation

When we speak of repeated multiplication, we are also including repeated division. This is because any division can be seen as a multiplication and vice-versa. For example, dividing by 2 is the same as multiplying by 0,5 or equivalently $\frac{1}{2}$. Another example is by dividing by $\frac{4}{3}$ is the same as multiplying by $\frac{3}{4}$.

3.1 Introducing repeated multiplication

Belt drive situation

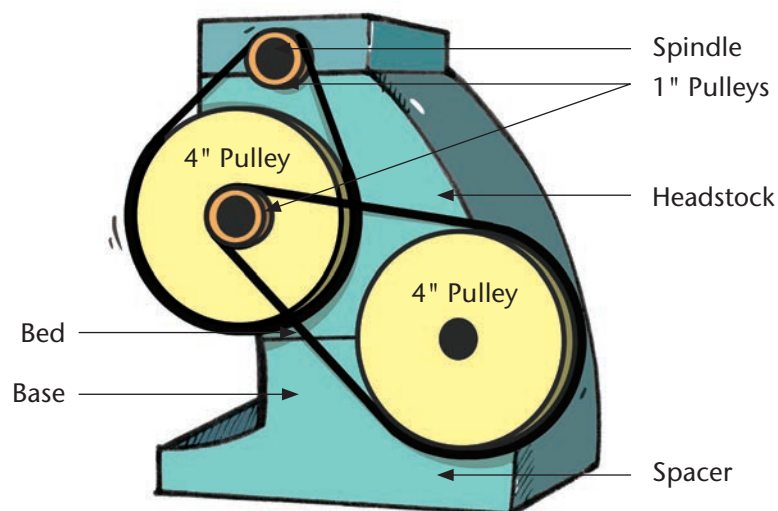

Note: in some situations you will have to work in the old, non-metric measurements of feet and inches. These are still used in the USA for instance. An inch is approximately 2,50 cm and there are 12 inches in a foot. There is a shorthand form of writing feet and inches, e.g. if someone is 5 foot 2 inches we can write this as 5 ft. 4 in., or even shorter as 5'4".

Beware that the same symbols, ' and ", are used for minutes and seconds in angular measure. See Chapter 10 for more on this.

The diagram represents a compound belt drive from a lathe. Each 4-inch diameter pulley is connected to a 1-inch diameter pulley. The 4" pulley at the bottom right is the driving pulley for the lathe. The 1" follower pulley is attached to the spindle.

Going from a 4" to a 1" pulley causes a speeding up effect of 4 times. If the 4" pulley turns at 20 rpm, then the 1" pulley will turn at 80 rpm. Linking the two pulley-drives causes a speeding up effect of 4×4 or 16 times.

What speeding up effect do we get if we link three such drives? If we link up four or even more?

Photomultiplier situation

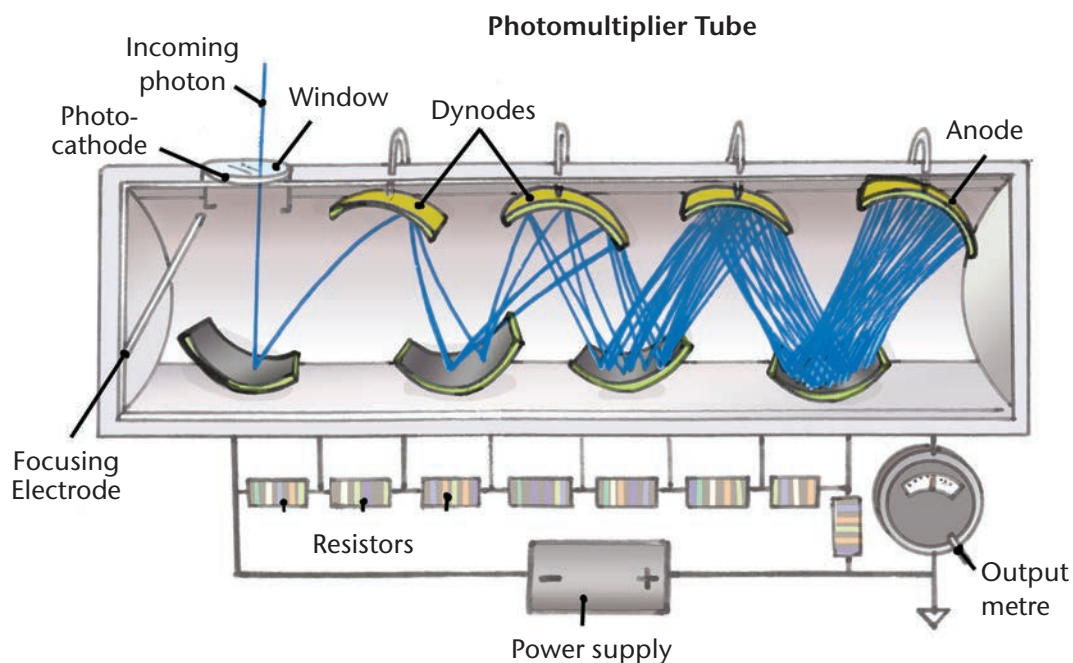

In some technical fields, such as nuclear technology, astronomy, etc., we need to test for very low levels of radiation. The measuring instrument has to convert very low intensity radiation into an electrical current.

Radiation exists in small amounts called photons. Each photon bumps an electron from the photocathode. This electron then collides with the first dynode to release two or more electrons. The process of electrons colliding with each dynode and releasing even more electrons continues from dynode to dynode.

You can see how, in the case of the photomultiplier in the diagram, each electron that hits one of the dynodes releases two electrons. These travel to the next dynode. There, each one releases two electrons. So, the current doubles from one dynode to the next. In the diagram, there are six dynodes, so the current at the anode will be $2 \times 2 \times 2 \times 2 \times 2 \times 2$ times the current caused by the photons at the photocathode.

Sound transmission situation

A recording studio needs to be soundproof. One way of soundproofing is to cover the walls with layers of sound-absorbing material.

Sound intensity is to sound what brightness is to light; the louder the sound, the higher the intensity. It is measured in watts per square metre.

Let us suppose that one layer of soundproof material allows 30%, i.e. a fraction $0,3$ or $\frac{3}{10}$, of the sound intensity through. Two layers will let through 30% of 30%, or $0,3 \times 0,3$. n layers will let $0,3 \times 0,3 \times 0,3 \times \dots \times 0,3$ i.e. n factors of $0,3$ of the original sound intensity through.

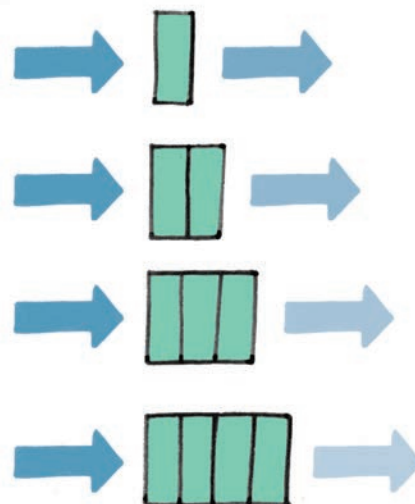

3.2 Notation for repeated multiplication and division

We can represent repeated multiplication using exponential notation. Here is a reminder about the basics.

Terminology and notation

- x^n called a **power**, is shorthand for $x \times x \times x \times \dots$ to n factors in particular, x^1 is the same as x
- x is called the **base**, and n the **exponent**
- we read x^n as 'x exponent n'
- x^{-n} is shorthand for $\frac{1}{x \times x \times x \times \dots \text{ to } n \text{ factors}}$, which is also the same as $\frac{1}{x^n}$

We can now state some basic properties of exponents using the standard notation.

Some basic properties of exponents

- $x^{-n} = \frac{1}{x^n}$, so long as $x \neq 0$
- $x^{-1} = \frac{1}{x}$, so long as $x \neq 0$
- $x^1 = x$
- $x^0 = 1$, so long as $x \neq 0$

Note: The last statement may seem confusing: How does one ‘multiply a number repeatedly zero times’? However, $x^0 = 1$.

Note: Mathematicians call the expression 0^0 an indeterminate expression. An expression such as 0^{-3} is called undefined. There is a difference, but we will not go into that now.

Exercises Basic revision of exponents and exponent notation

- 1 Refer to the photomultiplier situation in paragraph 3.1 and complete the table. You can use your calculator to help you with the *last column*. You can do repeated multiplication, one multiplication for each step, if you wish.

Current multiplier at each dynode	Number of dynodes	Combined current multiplier in expanded form	Combined current multiplier in exponential form	Combined current multiplier in numerical form
2	5	$2 \times 2 \times 2 \times 2 \times 2$	2^5	32
2	10			
3	5			
4	5			
			4^9	
6	5			
3				729
9				729
				15 625
		$1,5 \times 1,5 \times 1,5 \times 1,5 \times 1,5$		
				1

- 2 Refer to the sound transmission situation in paragraph 3.1.
 - (a) Show this in exponential form. What effect does it have if there is one layer?
 - (b) What happens if there are no layers i.e. zero layers? Show this in exponential form. You may have to think a little outside of the box here!

- 3 This diagram shows a side view and top view of a simple belt drive.

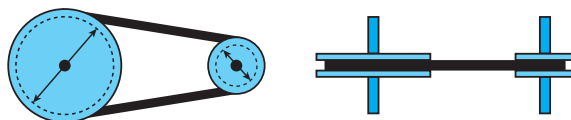

Let us suppose that the ratio of the diameter of the big pulley to the diameter of the small one is 3:1. Let us call the speeding up/slowing down effect of the belt drive, the *speed factor*.

- Do you agree with this statement: 'If the big pulley is the driver and the small one the follower, then the speed factor will be 3'?
- What is the speed factor if the small pulley is the driving pulley? Write this factor in different ways, include exponential notation.
- Compare the speed factors in (a) and (b). Can we say that the speed factors are reciprocals?

In exercises 4 and 5 you have to represent the effects of the different drives in as many ways as possible. Here is an example for you of what is expected. It gives some, but not all, of the ways you can write the expressions for a compound drive. The driver is on the left:

$$3 \times 3 \times \frac{1}{3} \times 3 \text{ (expanded form)}$$

$$3^2 \times 3^{-1} \times 3 \text{ or } 3^3 \times 3^{-1} \text{ (exponential forms)}$$

$$3^2 \text{ or } 9 \text{ (combined/effective forms)}$$

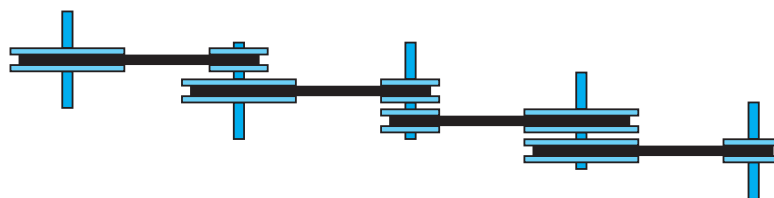

- 4 Imagine we connect four of the belt drives from exercise 3 to form a compound drive:

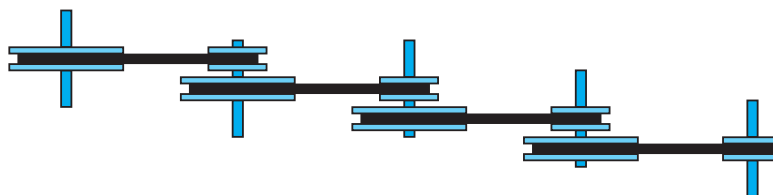

- If the large pulley on the left is the driver, what is the combined speed factor of the four drives together? Write this in different ways, including exponential notation.
- Answer the same question as in (a), but for the case where the small pulley at the right is the driver.
- Answer the same question as in (a) for the following compound drive:



- Answer the same question as in (a) for the following compound drive:



- (e) What do you realise about the effect of the two drives in (c), and the two drives in (d)? Explain this and represent your understandings in exponential notation. Which of the properties of exponents have been revealed here?

5 Again, using the same drives we introduced in exercise 3, consider the following three compound drives:

A

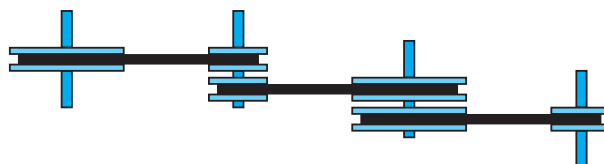

B

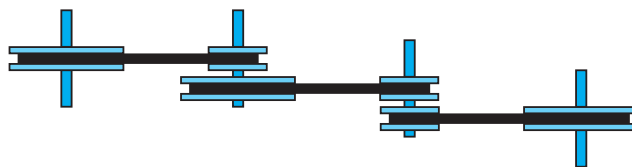

C

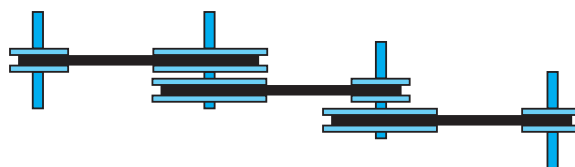

- (a) Assume that the left-most pulley is the driver. What is the effective speed factor for belt drive A? Explain how you see this and represent your explanation in exponential form. Do the same for compound belt drives B and C.
- (b) Now, assume that the right-most pulley is the driver. Determine the effective speed factor for the three compound drives A, B, and C. Explain how you see this and represent your explanation in exponential form.
- (c) Compare your findings in (a) and (b). Can we replace the compound drives with single belt drives of the same type?
- (d) Also compare the three compound drives with each other. What do you realise? Which of the properties of exponents have been revealed here?

Hopefully, you are convinced that the 'laws' of exponents are not really laws. They are actually properties of how we multiply a number with itself repeatedly.

3.3 The algebra of exponents

Four very important properties, sometimes called ‘laws’ of exponents

- $x^m \times x^n = x^{m+n}$ OR $x^m x^n = x^{m+n}$
- $x^m \div x^n = x^{m-n}$ OR $\frac{x^m}{x^n} = x^{m-n}$
- $(x^m)^n = x^{m \times n}$ OR $(x^m)^n = x^{mn}$
- $x^n \times y^n = (x \times y)^n$ OR $x^n y^n = (xy)^n$

Mathematicians will actually call the properties, laws. The word ‘property’ is much more meaningful. A property of something is a way it behaves or does things. We all know how multiplication behaves. So let’s be kind to ourselves and rather call the ‘laws’, properties.

Note that this is just a *list* of the properties. They are not supposed to be memorised. The properties should come to you as you need them *because* you do need them!

Additional notation

- Multiplication: for example, $a \times b$ can be written as $a.b$ and most economically as ab .
- Division: for example, $a \div b$ is also written as $\frac{a}{b}$, and also as $a.b^{-1}$, or even ab^{-1} .

Exercises Investigating and checking the properties

- 6 Write 7^{12} in five or more different ways using the following properties:
- (a) $x^m x^n = x^{m+n}$
 - (b) $\frac{x^m}{x^n} = x^{m-n}$
 - (c) $(x^m)^n = x^{mn}$
- 7 Use the property $x^n y^n = (xy)^n$ to write $3^6 \times 5^9$ in as many forms as you can.
- 8 Investigate how the properties apply to the belt drive situation. In each case, you need to show this in as many ways as you can. You must draw the belt drives for each of the ways. Clearly indicate the driver pulley in each case:
- (a) Use five belt drives, with speed factor 4, to show how $x^m x^n = x^{m+n}$ works
 - (b) Use four belt drives, with speed factor 5, to show how $\frac{x^m}{x^n} = x^{m-n}$ works.
 - (c) Use six belt drives, with speed factor 0,1, to show how $(xm)^n = x^{mn}$ works.
 - (d) Use three belt drives, with speed factor 2, and three with speed factor 5, to show how $x^n y^n = (xy)^n$ works.

- 9 Decide whether the following are correct or not. In each case, **justify** why you say so by giving the unknowns values and showing why they are correct or not correct.

(a) $\frac{x^m}{x^n} = \frac{1}{x^{n-m}}$

(b) $a^p b^q = (ab)^{pq}$

(c) $y^i \cdot y^j \cdot y^k = y^{i+j+k}$

(d) $x^m y^n = (xy)^m y^{n-m}$

To 'justify' means to explain that something is correct by using known facts or properties of the thing. You know that a justification is acceptable if it makes sense to you and anyone else you share it with.

- 10 Which of the following expressions are equivalent to $9^2 \times 2^3$?

(a) 8×3^4

(b) $9^2 \times 4^1$

(c) 81×8

(d) $18 \times 4 \times 3^2$

(e) $18 \times 12 \times 3$

(f) $3^4 \times 2^3$

(g) 18^5

(h) $4^2 \times 9^2 \div 2$

(i) $6^4 \div 2$

(j) 3×6^3

(k) $18^3 \div 3^2$

(l) 2×18^2

(m) 648

- 11 Write each of the following expressions in at least five equivalent forms:

(a) $5^2 \times 5^7$

(b) $8^0 \times 8^8$

(c) $x^5 \times x^4$

(d) $6^{p+1} \times 6^{3p+3}$

(e) $4^6 \div 4^3$

(f) $7^5 \div 7^4$

(g) $y^8 \div y^6$

(h) $2^{3p+3} \div 2^{p-2}$

(i) $(2^3)^4$

(j) $(x^{-3})^{-5}$

(k) $(3^2)^{x-3}$

(l) $(7^{-2})^3$

(m) $5^7 \times 3^4$

(n) $8^1 \times 2^5$

(o) $x^5 y^2$

(p) $6^2 \times 5^2$

3.4 Simplifying

In exercise 10, all the expressions except (b) and (g) are equivalent to the given expression. Which expression is the simplest? What exactly do we mean by 'simplest'?

Simplifying an expression does not only mean writing down the shortest equivalent expression. We can argue that the expression in (m) is the simplest in that case. The simplest exponential expression is actually in (f).

We will begin with a worked example and then make the reasons clear.

Important: When you are asked to simplify something, you can use your calculator to do much of the work for you. However, as a mathematics learner it is much better for you to do the work yourself. In that way, you practise using maths, which will empower you in the long run. For this reason, *you will be expected to show all your working for now.*

Worked example Simplest exponential form

Problem: Simplify the expression $\frac{6^3}{4 \cdot 9^2}$, showing all your working.

Solution: First notice, that we cannot apply any of the laws to this expression because the bases are all different. However, we know that 6 is made up of the prime factors 2 and 3. Similarly, 4 and 9 also have prime factors.

Step 1: Express all the bases in their smallest whole number prime factors:

$$6 = 2 \cdot 3 \qquad 4 = 2 \cdot 2 = 2^2 \qquad 9 = 3 \cdot 3 = 3^2$$

Rewrite the given expression using prime factors of the bases:

$$\frac{6^3}{4 \cdot 9^2} = \frac{(2 \cdot 3)^3}{2^2 \cdot (3^2)^2}$$

Step 2: The expression is crying out to be simplified now.

Use the properties of exponents:

$$\begin{aligned} \frac{6^3}{4 \cdot 9^2} &= \frac{(2 \cdot 3)^3}{2^2(3^2)^2} \\ &= \frac{2^3 \cdot 3^3}{2^2 \cdot 3^4} \\ &= \frac{2}{3} \end{aligned}$$

You could write out the factors in expanded form and then simplify the resulting

expression: $\frac{6^3}{4 \cdot 9^2} = \frac{(2 \cdot 3)^3}{2^2(3^2)^2} = \frac{(2 \cdot 3)(2 \cdot 3)(2 \cdot 3)}{2^2(3^2)(3^2)} = \frac{2 \cdot 2 \cdot 2 \cdot 3 \cdot 3 \cdot 3}{2 \cdot 2 \cdot 3 \cdot 3 \cdot 3 \cdot 3} = \frac{2}{3}$

But this is something you should try to avoid. The whole idea is to become good at dealing with exponential expressions and their algebra. We need to keep moving forwards!

What do we mean by ‘simplest exponential form’?

Simplest form with exponents, refers to leaving all bases in prime factor form with each prime factor appearing only once.

Why do we write expressions in simpler form?

Simpler expressions are a way for us to write things so that the structure of the parts is as simple as possible to see.

We can see this for exponential expressions if we refer back to Exercise 10. Which equivalent expression does all of the following:

- Shows the number structure using prime factors?
- Doesn't repeat prime factors?
- Is in exponential form?

Only the expression $2^3 \times 3^4$ does the job. All of the others fall short with one or more of these requirements. In other words, they hide some of the structure of the expression.

Worked Example Another expression simplified

Problem: Simplify $\frac{24 \times 9^2}{18^4}$

Solution:

Step 1: Express all bases as prime factors.

$$24 = 2 \times 2 \times 2 \times 3 \text{ or } 2^3 \times 3 \qquad 9 = 3^2$$

$$18 = 2 \times 9 = 2 \times 3^2$$

Step 2: Simplify

$$\begin{aligned} \frac{24 \times 9^2}{18^4} &= \frac{(2^3 \times 3) \times (3^2)^2}{(2 \times 3^2)^4} \\ &= \frac{2^3 \times 3^5}{2^4 \times 3^8} \\ &= \frac{1}{2 \times 3^3} \\ &= \frac{1}{54} \end{aligned}$$

You may want to rewrite the last expressions as $\frac{1}{6 \times 3^2}$. There is nothing mathematically wrong with that because it is equivalent. However, it just isn't in simplest exponential form because the base 6 is not a prime number.

You may remember this way of finding prime factors:

2	24
2	12
2	6
3	3
	1

Convention: When you have to do this in a test or exam, the exponents in your answers have to be positive. Read the question carefully. It should tell you what you need to do. *If it doesn't, always write your exponents as positive numbers.*

Important: Sometimes, in a test or exam, you will be asked to give 'the simplest form' and not 'the simplest exponential form' of an exponential expression. You may even just be asked to 'simplify'. We always mean *simplest exponential form*.

Exercise

12 Simplify the following using exponential forms.

(a) 2×2^7

(b) $2^3 \cdot 2^5$

(c) $2^2 \times 2^3 \times 2^3$

(d) $2^3 \times 3^3$

(e) $2^5 + 2^4$

(f) $2^5 - 2^4$

(g) $\frac{2^4}{2^{11}}$

(h) $2 \div 2^8$

(i) $3^{-2} \cdot 2.5^{-1}$

(j) $3^{-2} \cdot (2.5)^{-1}$

(k) $(13^3 \times 36^{-2})^0$

(l) $(5^5)^5$

(m) $3^3 \div 4^{-3}$

(n) $2^{-7} \times 2^5$

(o) $2^{-7} \cdot 2^7$

(p) $36^3 \cdot 36^0$

(q) $3 + 3^{-1}$

(r) $3^3 - 2^2$

$$(s) \frac{9 \times 12^5}{4^3 \times 6^4}$$

$$(t) 25^{2.36 - 1.2700}$$

$$(u) \frac{10^8}{20^2 \cdot 25^3 \cdot 8}$$

$$(v) 6^5 \times 9^{-3} \times 12^4 \times 16^{-4} \times 18^{-3} \quad (w) \frac{4^4 \times 18^3}{9^2 \times 6^7 \times 2^{-1}}$$

$$(x) \frac{45^2 \cdot 12}{36\,000} \times \frac{20^4}{30^4}$$

Working with unknown exponents

Advice: If you have any trouble with these simplifications, try doing them with number values for the exponents. Then try to see how to do them with the variable exponents. The steps are basically the same.

Worked example Simplifying expressions involving variable exponents

Problem: Simplify $\frac{15^{2x}}{5^x \times 10^x \times 3^{2x}}$

Solution: As before, bases must be in prime form, so we begin with that:

Step 1: Bases in prime factors

$$10 = 2 \times 5 \quad 15 = 3 \times 5$$

Step 2: Simplify

$$\begin{aligned} \frac{15^{2x}}{5^x \times 10^x \times 3^{2x}} &= \frac{(3 \times 5)^{2x}}{5^x \times (2 \times 5)^x \times 3^{2x}} \\ &= \frac{3^{2x} \times 5^{2x}}{5^x \times 2^x \times 5^x \times 3^{2x}} \\ &= \frac{3^{2x} \times 5^{2x}}{2^x \times 3^{2x} \times 5^{2x}} \\ &= \frac{1}{2^x} \end{aligned}$$

Note that we can try writing all the factors in expanded form. Can you see that it will be messy?

$$\frac{15^{2x}}{5^x \times 10^x \times 3^{2x}} = \frac{(3 \times 3 \times 3 \times \dots \text{to } 2x \text{ factors}) \times (3 \times 3 \times 3 \times \dots \text{to } 2x \text{ factors})}{\text{etc.}}$$

It is clear why we have the ‘laws’ that are just important properties. They summarise our understanding of normal multiplication and division applied to repeated multiplication. When the exponents are variables, the properties still apply, as long as we trust that they work!

Note that we cannot really speak of ‘positive’ exponents here. Is x positive here? We don’t know. We have to assume x can be any integer, including negative ones. Usually, when we simplify expressions like this one, we try to make sure there are no negative signs in the exponents. So, usually, in exams and tests, you are expected to give the first simplified form, $\frac{1}{2^x}$, even though the second 2^{-x} is perfectly correct and just as simple!

Worked example Simplifying with variable bases

Problem: Simplify $\frac{(ab^4)^5 \times a^3b^2}{(a^2b^3)^5}$

Solution: Since our bases a and b are variables, we cannot break them into prime factors. The bases a and b are the ‘smallest’ factors we can actually talk about here, so we simplify in terms of them as follows:

$$\begin{aligned}\frac{(ab^4)^5 \times a^3b^2}{(a^2b^3)^5} &= \frac{a^5b^{20} \times a^3b^2}{a^{10}b^{15}} \\ &= \frac{a^8b^{22}}{a^{10}b^{15}} \\ &= \frac{b^7}{a^2}\end{aligned}$$

We could also expand the different expressions since the exponents are known to us:

$$\begin{aligned}\frac{(ab^4)^5 \times a^3b^2}{(a^2b^3)^5} &= \frac{ab^4 \cdot ab^4 \cdot ab^4 \cdot ab^4 \cdot ab^4 \times a^3b^2}{a^2b^3 \cdot a^2b^3 \cdot a^2b^3 \cdot a^2b^3 \cdot a^2b^3} \\ &= \frac{a^5b^{20} \times a^3b^2}{a^{10}b^{15}} \\ &= \frac{a^8b^{22}}{a^{10}b^{15}} \\ &= \frac{b^7}{a^2}\end{aligned}$$

Exercise Practise simplifying expressions involving variable bases and exponents

13 Simplify the following expressions into simplest exponential form.

(a) $p^2q \times p^4q^5$

(b) $p^3q^{-1} \times p^3q^7$

(c) $\frac{2}{3}a^{-2} - \left(\frac{3}{a^{-2}}\right)^{-1}$

(d) $3^{2n} \times 9^{m-n}$

(e) $(3a^3)^3 + 2(3a^3)^3$

(f) $\frac{(73s^{-13})^0}{2^{-2}(2p)^{-2}}$

(g) $\frac{1}{2} \left(\frac{4^{h+5}}{16 \cdot 2^{2h}} \right)$

(h) $\frac{3^{5x-1} \cdot 81^{2x+1}}{27^{4x+1}}$

(i) $\frac{16^{2y+2} \times 4^{1-y}}{64^{y+2}}$

(j) $\frac{49a^5b^3c}{14(a^2bc)^2}$

(k) $2^a \cdot 10^{2a-1} \cdot 25^{1-a} \cdot 4^{3a} \cdot 8^{-3a}$

(l) $\frac{3^{z-1} \times 45^{3z-1} \times 25^{2-z}}{15^{z+1} \times 27^{2z}}$

(m) $\frac{ab \times (2b^2)^2 \times 6a^9b^7}{(2b^4)^3 \times 8(a^5b^{-2})^2}$

(n) $\frac{a^{3x+2y+z} \cdot a^{x+3y-z}}{a^{4x+5y}}$

3.5 Exponential equations

This section is about setting up and solving exponential equations.

Exponential equations occur in situations where there is repeated multiplication or division. However, *the number of times the repeated multiplication or division occurs is unknown* and needs to be calculated.

Worked example

Problem: Refer to the photomultiplier situation.

A particular photomultiplier has a certain unknown number of dynodes. Each dynode has a doubling effect on the current. The entire set of dynodes causes the current to increase by a factor of 128. How many dynodes are there?

Solution:

Step 1: Express the problem as an equation.

The base is 2; the multiplying effect on the current caused by each dynode.

Let the number of dynodes be n .

Now we can write an equation: $2^n = 128$.

Step 2: Find the prime factors of 128.

If we can express 128 in the base 2, then we can find a solution easily. Dividing 128 by 2 a few times shows us that $128 = 2^7$.

Step 3: Solve the equation:

$$2^n = 128 = 2^7$$

Therefore, the exponents must be the same and $n = 7$. There are 7 dynodes in the photomultiplier.

Worked example

Problem: Bacterial growth

At 2 o' clock, the total number of bacteria in a skin wound is 35 000. The number of bacteria doubles every 45 minutes. When will the number of bacteria be 560 000?

Solution:

Step 1: Let the number of 45 minute periods be n .

Therefore, the number of bacteria later = number of bacteria to begin with $\times 2^n$.

Step 2: Solve the equation

$$\begin{aligned}560\,000 &= 35\,000 \times 2^n \\2^n &= \frac{560\,000}{35\,000} \\2^n &= 8\end{aligned}$$

So, then n must be 3 because $8 = 2^3$.

Step 3: Interpret the solution

So, $n = 3$, which means that this happens 3×45 minutes = 135 minutes later. 135 minutes is 2 hours and 15 minutes, so this will happen at 4:15.

Exercises Some equations and some problems that lead to equations

14 Solve the following equations, showing all your steps.

(a) $2^n = 8$

(b) $3 \cdot 2^x = 24$

(c) $2^{2a} = 8$

(d) $2^{n+1} = 8$

(e) $(2^n)^3 = 8$

(f) $2^n = 8^n$

(g) $2^{2y-3} = 8^{y+2}$

(h) $7^{x^2-9} = 1$

(i) $5^{2n+1} = \frac{1}{125}$

(j) $(b^m)^3 = b^{12}$

(k) $b^m \cdot b^3 = b^{12}$

(l) $(b^{m+3})^3 = b^{12}$

(m) $3^{x^2+5x+6} = 1$

(n) $8\left(\frac{7}{2}\right)^p = 343$

(o) $4^{2x} - 2^{-1} = -0,25$

(p) $(3 \cdot 5^k)^3 + 2(3 \cdot 5^k)^3 = 405$

(q) $\frac{64^{2x+1}}{16^{x-2}} = 256$

(r) $8.4y = 4.2y$

(s) $8.4y = 8.2y$

(t) $12.3^y = 4.3^{(2y)}$

- 15 Refer to the sound transmission situation.

Refilwe is building a home recording studio. She plans to divide a spare room into a studio, where the music is played, and a control room, where all the recording equipment is. The wall, ceiling, and floor itself must be suitably soundproof.

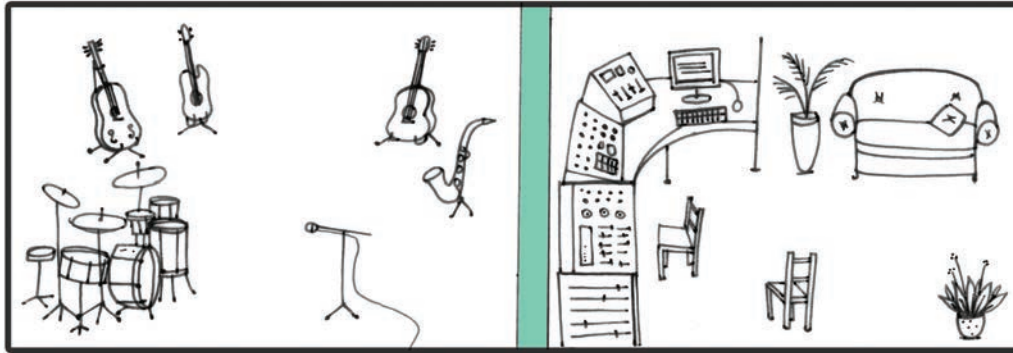

Studio

Control Room

She estimates that the maximum sound intensity of the music in the studio will be $5 \times 10^{-3} \text{ W/m}^2$. She wants the sound intensity in the control room to be at a low conversation level of $5 \times 10^{-7} \text{ W/m}^2$.

The panels she will be using for the wall transmit 10% of the sound that enters them, and therefore, absorb the other 90%.

How many layers of the panelling does she need for the wall?

- 16 A capacitor is fully charged. When it is connected to a high resistance circuit, it is found that the charge halves every 8 s (seconds). How long will it take for the capacitor to be discharged to:

- (a) 50%? (b) 12,5%?
(c) 3,125%? (d) less than 1%?

If this model of discharge is correct, can the capacitor ever have a zero charge?

- 17 Refer to the belt drive situation. A single belt drive with speed factor 0,2 is connected to a certain number of belt drives, with speed factor 3. The effective speed factor of the combined belt drive system is 48,6.

- (a) How many of the belt drives with speed factor 3 were used?
(b) Does it make any difference to your solution if the belt drive with speed factor 0,2 is connected between the other drives? Explain briefly (mathematically and in terms of practical reality).

- 18 Kesivan has R3 072 in his petty cash box. Every week he takes out half of all the money left in the box. After a certain number of weeks, he realises that he only has R1,50 left. How many times did Kesivan take money from the petty cash box?

3.6 Scientific notation and significant figures

Scientific notation is a way of writing a decimal number as a factor greater than -10 and less than 10 , multiplied by a power of 10 . Only the significant figures are shown.

Significant figures are the figures or digits in a decimal number that form part of the value of the number. This may seem strange, but not all digits in a decimal number have to do with the number itself. See the following examples for how this happens.

Example Common fractions in scientific notation

An eighth $\left(\frac{1}{8}\right)$ is $0,125$ in decimal form. A seventh $\left(\frac{1}{7}\right)$ is $0,142\ 857$ recurring in decimal form.

We can write these fractions using powers of ten, as follows:

$$0,125 = (1 \times 10^{-1}) + (2 \times 10^{-2}) + (5 \times 10^{-3}) \text{ exactly}$$

$$0,142\ 857 = (1 \times 10^{-1}) + (4 \times 10^{-2}) + (2 \times 10^{-3}) + (8 \times 10^{-4}) + (5 \times 10^{-5}) + (7 \times 10^{-6}) + \dots \text{ recurring}$$

The 0 before the comma is just a place-holder in decimal notation. Only the 1 , 2 , and 5 are significant in an eighth, and all the repeating 1 , 4 , 2 , 8 , 5 , and 7 in a seventh are significant.

An eighth in scientific notation:

The whole of $\frac{1}{8}$ is present in $(1 \times 10^{-1}) + (2 \times 10^{-2}) + (5 \times 10^{-3})$.

We can rewrite $0,125$ so that it contains only the significant figures 1 , 2 , and 5 , leaving out the place-holder, 0 :

$$\begin{aligned} 0,125 &= (1 \times 10^{-1}) + (2 \times 10^{-2}) + (5 \times 10^{-3}) \\ &= (1 \times 10^0) + (2 \times 10^{-1}) + (5 \times 10^{-2}) \times 10^{-1} \\ &= 1,25 \times 10^{-1} \end{aligned}$$

This last form of an eighth is written in scientific notation, showing all three significant figures. We round off $1,25 \times 10^{-1}$ to two or one significant figures:

Two significant figures: $1,3 \times 10^{-1}$

One significant figure: 1×10^{-1}

We see that rounding off has removed some of the information needed to give the full value of an eighth.

A seventh in scientific notation:

We cannot write out the whole of $\frac{1}{7}$ as powers of 10. This means, we are forced to round off to a suitable number of significant figures:

Ten significant figures: $1,428\,571\,429 \times 10^{-1}$

Six significant figures: $1,428\,57 \times 10^{-1}$

Three significant figures: $1,43 \times 10^{-1}$

Two significant figures: $1,4 \times 10^{-1}$

One significant figure: 1×10^{-1}

We see that an eighth and a seventh are the same to one significant figure but different to two or more significant figures. An eighth is completely described to three significant figures but a seventh is not, and because it is recurring, never can be.

Example Different significant figures and rounding off

Four different capacitors, A, B, C, and D, have the following capacitances, measured in Farad (F):

A	0,000 002 3 F	known to two significant figures
B	0,000 002 30 F	known to three significant figures
C	0,000 002 34 F	known to three significant figures
D	0,000 002 35 F	known to three significant figures

We can write these capacitances as:

$$A \quad (2 \times 10^{-6}) + (3 \times 10^{-7}) F = 2,3 \times 10^{-6} F$$

$$B \quad (2 \times 10^{-6}) + (3 \times 10^{-7}) + (0 \times 10^{-8}) = 2,30 \times 10^{-6} F$$

$$C \quad (2 \times 10^{-6}) + (3 \times 10^{-7}) + (4 \times 10^{-8}) = 2,34 \times 10^{-6} F$$

$$D \quad (2 \times 10^{-6}) + (3 \times 10^{-7}) + (5 \times 10^{-8}) = 2,35 \times 10^{-6} F$$

The capacitances of A and B are not the same. The 0 at the end of the capacitance of B is significant. We don't know if capacitor A has a third significant digit. If it does, there are ten possibilities:

- If the second significant figure is 3, then the third has to be one of 0, 1, 2, 3, or 4.
- If the second significant figure is 2, then the third has to be one of 5, 6, 7, 8, or 9.

If we round off the capacitances of B, C, and D to two significant figures, then A, B, and C have the same capacitances, but D has a different capacitance.

Note that when we round off, we lose significant figures. Saying A, B, and C have the same capacitances to two significant figures does not mean that they have the same capacitances!

Worked example Speed of light compared to speed of sound

Problem: The speed of light in a vacuum, e.g. in space, is 2 997 925 km/s.

The speed of sound under standard conditions is 331,3 m/s.

Solution: In scientific notation:

$$2\,997\,925 \text{ km/s} = 2,997\,925 \times 10^6 \text{ km/s} = 2,997\,925 \times 10^8 \text{ m/s} \quad \text{and}$$

$$331,3 \text{ m/s} = 3,313 \times 10^2 \text{ m/s}$$

If we round the speed of light off to the same number of significant figures as the speed of sound, we can compare the values meaningfully. To two significant figures:

$$\text{Speed of light:} \quad 3,0 \times 10^8 \text{ m/s}$$

$$\text{Speed of sound:} \quad 3,3 \times 10^2 \text{ m/s}$$

We can see that the speed of light is just less than 10^6 or a million times the speed of sound.

Why do we use scientific notation?

We have seen one reason:

- To express a number using only the significant figures, or rounded to a certain number of significant figures.

Another reason has to do with numbers that are either very small or very large in the units we are measuring or expressing

- Very large numbers, say bigger than 10 000, or very small numbers, say smaller than 0,000 01 are much easier to write down and to read and understand when we write them in scientific notation. See the exercises below for examples.
- It becomes easier to compare different values if we write them all in terms of the same power 10. See the example of the speed of light/speed of sound given above and some of the exercises below for examples of this.

Exercise

19 In each case, express the number in scientific notation and also give the number of significant figures:

(a) 8 000

(b) 8

(c) 0,008

(d) 100 000

(e) 365,25

(f) 0,000 023 4

(g) 450 628,9

(h) 0,000 000 000 000 096 00

- (i) mass of a proton: 0,000 000 000 000 000 000 000 000 001 673 kg
- (j) a light year: $2\,997\,925 \text{ km/s} \times 365 \times 24 \times 60 \times 60 \text{ s/year}$
- (k) radius of the nucleus of a gold atom: 0,000 000 000 000 007 3 m
- (l) radius of a gold atom: 0,000 000 000 13 m
- (m) How many times bigger is the radius of a gold atom compared to the radius of its nucleus? Do not do any calculations; rather estimate the answer to the nearest power of ten from the answers you gave in (k) and (l).
- (n) density of the nucleus of a gold atom: $200\,000\,000\,000\,000\,000 \text{ kg/m}^3$
- (o) density of gold: $19\,320 \text{ kg/m}^3$
- (p) How many times smaller is the density of gold compared to the density of the nucleus of a gold atom? Estimate this in the same way as in (m).

Simplifying expressions involving scientific notation

Worked example

Problem: Simplify $\frac{(1,2 \times 10^3) \times (2,1 \times 10^{-2})}{(4 \times 10^2)}$

Solution: This one can be done without a calculator, as follows:

$$\begin{aligned} \frac{(1,2 \times 10^3) \times (2,1 \times 10^{-2})}{(4 \times 10^2)} &= \frac{1,2 \times 2,1 \times 10}{4 \times 10^2} \\ &= \frac{0,3 \times 2,1}{10} \\ &= 0,63 \times 10^{-1} \\ &= 6,3 \times 10^{-2} \end{aligned}$$

The answer here should be rounded off to 6×10^{-2} . The reason for this is that 4×10^2 is known only to 1 significant figure. Our final answer should reflect this. We cannot assume the value of the second significant figure without more information. Rounding to 6×10^{-2} is

being very honest about how much you know about the expression $\frac{(1,2 \times 10^3) \times (2,1 \times 10^{-2})}{(4 \times 10^2)}$.

Exercise

20 Do all of the following calculations without a calculator. Give your final answer to the least number of significant figures of all the numbers.

(a) $(4,2 \times 10^3) \times (6,0 \times 10^5)$

(b) $(-4,2 \times 10^3) \div (-6,0 \times 10^5)$

(c) $(8,1 \times 10^{-4}) \times (1,2 \times 10^5)$

(d) $(8,1 \times 10^{-4}) \div (1,2 \times 10^5)$

(e) $\frac{(1,25 \times 10^3) \times (1,6 \times 10^{-4})}{(-4,0 \times 10^{-2})}$

(f) $(5,35 \times 10^3) + (6,5 \times 10^2)$

(g) $(3,6 \times 10^{-3}) - (6,0 \times 10^{-4})$

(h) $\frac{(1,25 \times 10^9) + (5,0 \times 10^8)}{(1,4 \times 10^6)}$

Scientific notation on your calculator

There are two ways you can enter numbers in scientific notation on your calculator. The long and obvious way is to key in the whole expression. However, because scientific notation is so important, your calculator will have a key for it. Refer to your calculator's user manual and ask your teacher to help you set up your calculator.

Exercise

21 Redo exercise 20 with your calculator.

Optional: precision and accuracy

We use the word **precision** to describe the number of significant figures in a value. The more significant the figures, the greater the precision.

The word **precise** is used to describe how close the value is to the correct value. Very precise values may not be very accurate values.

3.7 Kilo-, nano-, mega-, micro-, and more

Worked example

Problem: Refer to the capacitor A in the situation mentioned in the previous section.

Solution: We showed before that the capacitance $0,000\ 002\ 3\ F$ can be written in scientific notation as $2,3 \times 10^{-6}\ F$. The power factor is $10^{-6} = \frac{1}{1000000}$, or a millionth. So, our capacitor has a capacitance of 2,3 millionths of a Farad.

Many capacitors have similarly small capacitances. Instead of writing the power factor 10^{-6} each time, we abbreviate and write it as $2,3\ \mu F$.

The **prefix ‘μ’** called ‘micro-’, tells us that we are dealing with millionths of a Farad, i.e. μ stands for ‘ $\times 10^{-6}$ ’.

Prefixes for powers of 10

Other shorthand prefixes for the power part of scientific notation, are:

10^{-12}	10^{-9}	10^{-6}	10^{-3}	10^{-2}	10^{-1}	10^{-0}	10^1	10^2	10^3	10^6	10^9	10^{12}
pico	nano	micro	milli	centi	deci	–	deca	hecto	kilo	mega	giga	terra
p	n	μ	m	c	d		da	h	k	M	G	T

Note that **micrometres** are often called **microns** and $10^{-10}\ m$ is called an **ångström** (Å). An ångström is a tenth of a nanometre.

Examples

- The CPU clock rate on a computer is $3,2\ GHz = 3\ 200\ 000\ 000\ Hz$.
- A bacterium is typically about $1\ \mu m = 0,001\ mm$ in length.
- A standard ruler is $3\ dm = 30\ cm$ long.
- A South African household needs between $3\ and\ 5\ kW = 3\ 000\ to\ 5\ 000\ W$ of electrical power at peak usage.

Exercise

22 Write each of the following numbers in the way requested. All numbers must be given in scientific notation where appropriate.

- | | |
|-------------------|-----------------------------|
| (a) 3,80 MW in kW | (b) 3,80 MW in W |
| (c) 3,80 MW in GW | (d) 5,7 mA in μA |
| (e) 5,7 mA in nA | (f) 18 nm in μm |
| (g) 18 nm in mm | (h) 18 nm in m |
| (i) 18 nm in km | (j) 18 nm in \AA |
| (k) 175 cg in mg | (l) 175 cg in dg |
| (m) 175 cg in dag | (n) 175 cg in HG |

3.8 Conversion between units

Worked example

Problem: How many square millimetres are there in a square centimetre?

Solution: Let the big blue square be an *enlargement* of a square with side lengths of 1 cm.

We know there is 10 mm in a cm.

The area of the big square is 1 cm^2 .

One of the small squares is 1 mm^2 .

How many small squares are there?

There are 10 rows of 10, i.e. $10 \times 10 = 10^2$ of them.

So, 10^2 mm^2 is the same area as 1 cm^2 .

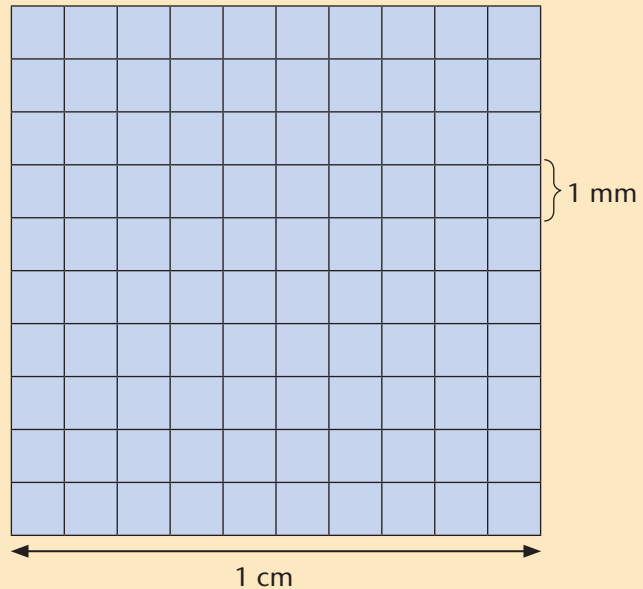

Worked example

Problem: How many square millimetres are there in a square decimetre?

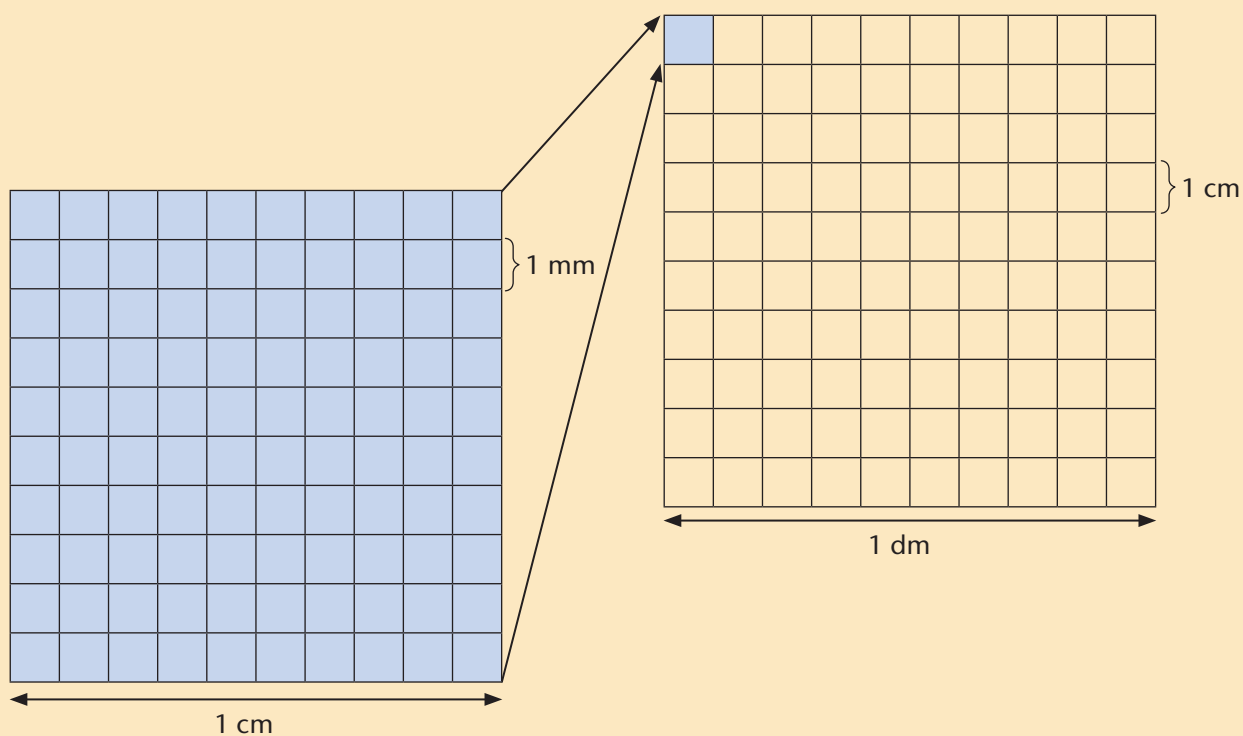

Solution: In the above diagram the pink square has sides of length 1 dm. The blue square is as in the previous example.

There are $10^2/100$ one millimetre squares in each 1 cm^2 square.

Since $1 \text{ dm} = 10 \text{ cm}$, there are 10^2 cm^2 in 1 dm^2 .

So, there must be $10^2 \times 10^2$ or 10^4 square mm in a square dm.

What can we learn?

We know that $1 \text{ dm} = 10 \text{ cm} = 10^2 \text{ mm}$.

So, $(1 \text{ dm})^2 = (10 \text{ cm})^2$, which means that $1 \text{ dm}^2 = 10^2 \text{ cm}^2$.

Similarly, $(1 \text{ dm})^2 = (100 \text{ mm})^2$, which means that $1 \text{ dm}^2 = 100^2 \text{ mm}^2$ or 10^4 mm^2 .

The number of mm^2 in 1 m^2 : $(1 \text{ m})^2 = (10^3 \text{ mm})^2$, which means that $1 \text{ m}^2 = 10^6 \text{ mm}^2$.

Worked example

Problem: Express $38,5 \text{ cm}^2$ in m^2 .

Solution:

Step 1a: Identify the conversion factor and express cm in terms of m:

$$10^2 \text{ cm} = 1 \text{ m} \text{ which means } 1 \text{ cm} = 10^{-2} \text{ m.}$$

Step 1b: Express cm^2 in terms of m^2 :

$$1 \text{ cm}^2 = (10^{-2})^2 \text{ m}^2 = 10^{-4} \text{ m}^2$$

Step 2: Now we can answer the question:

$$\begin{aligned} 38,5 \text{ cm}^2 &= 38,5 \times 10^{-4} \text{ m}^2 \\ &= 3,85 \times 10 \times 10^{-4} \text{ m}^2 \\ &= 3,85 \times 10^{-3} \text{ m}^2 \end{aligned}$$

In this example, we are going from cm^2 to m^2 , i.e. from a smaller unit to a bigger one. This means there must be a smaller value for the area in m^2 than it is in cm^2 .

Worked example

Problem: How many cubic millimetres in a cubic metre?

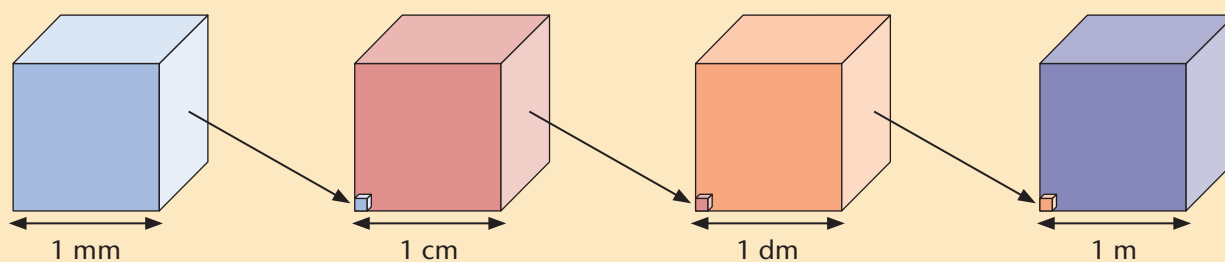

Each block is drawn twice, e.g. the 1 mm^3 block on the left, is shown at the bottom left corner of the 1 cm^3 block in miniature form. This continues across to the 1 mm^3 block. Try to imagine just how tiny the 1 mm^3 block is in the 1 m^3 block.

Solution: We can work as before:

The 1 m^3 cube has 10 layers of 1 dm^3 cubes, each layer having 10^2 of them.

So, there are 10^3 one dm^3 cubes in a 1 m^3 cube,

10^3 one cm^3 cubes in a 1 dm^3 cube,

and 10^3 one mm^3 cubes in a 1 cm^3 cube.

What can we learn?

Since we know that $1 \text{ m} = 10 \text{ dm} = 10^2 \text{ cm} = 10^3 \text{ mm}$, we can say that

$$(1 \text{ m})^3 = (10 \text{ dm})^3 = (10^2 \text{ cm})^3 = (10^3 \text{ mm})^3, \text{ or that}$$

$$1 \text{ m}^3 = 10^3 \text{ dm}^3 = 10^6 \text{ cm}^3 = 10^9 \text{ mm}^3.$$

Note that one cubic decimetre is almost exactly the same as one **litre**.

Worked example

Problem: Express the density of gold, $19,32 \text{ g/cm}^3$ in kg/m^3 .

Solution:

Step 1: Find the conversion factors:

$$1 \text{ cm} = 10^{-2} \text{ m, so } 1 \text{ cm}^3 = (10^{-2})^3 \text{ m}^3 = 10^{-6} \text{ m}^3$$

$$1 \text{ g} = 10^{-3} \text{ kg}$$

Step 2: Convert

$$\begin{aligned} 19,32 \text{ g/cm}^3 &= 19,32 \times \frac{1 \text{ g}}{1 \text{ cm}^3} \\ &= (1,932 \times 10) \times \frac{(10^{-3}\text{kg})}{(10^{-6}\text{m}^3)} \\ &= 1,932 \times 10^4 \text{ kg/m}^3 \end{aligned}$$

Exercise

23 Convert the following numbers to the required units:

- How many square mm are there in 2 cm^2 ?
- How many square cm are there in 3 dm^2 ?
- How many square mm are there in 5 m^2 ?
- Express $98,23 \text{ cm}$ in m^2 .
- Express $45,88 \text{ mm}$ in m^2 .
- A student prepares 250 mg per 50 ml of medicine A. Express this in g/l .
- If there are 3 patients requiring $125 \text{ mg}/50 \text{ ml}$ of medicine A, how much medicine should the student prepare? Express your answer in mg/ml and in g/l .
- What is $65,56 \text{ g/cm}^3$ expressed as kg/m^3 ?
- A construction company needs to remove $20\,000\,000 \text{ g/m}^3$ in half a day. How can you express this in kg/m^3 ?
- How much earth will the construction company in (i) remove in two days?

3.9 Summary

- Grade 10 Exponents really are all about **repeated multiplication** and counting factors.
- You learned that the **power** x^n is a short way of writing $x \times x \times \dots \times x$ n times. We call x the **base** and n the **exponent**. We read x^n as ‘ x exponent n ’ or ‘ x to the power n ’. You also learned that x^{-n} is shorthand for $\frac{1}{x^n}$ and that $x^0 = 1$ unless x is zero, which is indeterminate. x may be zero so long as n is positive.
- A quick revision of the four **properties of exponents** – often called laws – form the basis of the **algebra of exponents**. They are just ways of writing repeated multiplication. The four very important properties are:
 - $x^m x^n = x^{m+n}$
 - $\frac{x^m}{x^n} = x^{m-n}$
 - $(x^m)^n = x^{mn}$
 - $x^n y^n = (xy)^n$
- **Simplifying expressions** requires expressing all the bases in their smallest whole number factors, called prime factors. After rewriting all the bases using prime factors, the expression may be simplified using the properties of exponents.
- Exponential **equations** have unknown exponents. To solve for the unknown exponent, it is necessary to express all bases using prime factors. Situations that involve repeated multiplication an unknown number of times can lead to exponential equations.
- **Scientific notation** is a way of writing a decimal number as a factor between -10 and 10 , multiplied by a power of 10 , showing only the significant figures. **Significant figures** are the digits in a decimal number that form part of the value of the number, and excluding all placeholder zeros. They are the only digits shown in scientific notation.
- Finally, you worked with kilo-, nano-, mega, and micro-, and conversion between units, where your knowledge of exponents and scientific notations assisted you in converting units and expressing them in the required units and in a readable manner. This includes being able to convert between two square units and to convert between two cubic units.

3.10 Consolidation exercises

1 Re-write the following in exponential form:

(a) $3 \times 3 \times 3 \times 3 \times 3$

(b) $4.5.5.3.3.3$

(c) $-2 \times -2 \times -2 \times -2$

(d) $7.7.x.x.x.y.y$

2 Without using a calculator, calculate the value of the following:

(a) 2^5

(b) $(-3)^3$

(c) 5.2^3

(d) -1^0

(e) $4 \times 2^{-2} + 3^2.5$

(f) $(-7)^0$

3 Find the values of the following:

(a) 12^0

(b) 0^{12}

(c) $(-12)^0$

(d) 0^{-12}

(e) 12^{12}

(f) 0^0

4 Simplify the following:

(a) $3^2.3^3$

(b) $8^5.8^{-3}.8^2$

(c) $5^{12} \div 5^9$

(d) $7^5.7^6 \div 7^0$

(e) $(15 - 8)^4$

(f) $\frac{8 \times 3^{10}}{2 \times 3^4}$

(g) $\frac{4^5}{2^4}$

(h) $5 \times 3^{-3} \times 2 \times 3^2$

(i) $5^{-2} \div 5^9$

(j) $\frac{7.2^5}{21.2^{12}}$

5 Simplify the following expressions:

(a) $5^2 \times 5^7$

(b) $8^0 \times 8^8$

(c) $x^5 \times x^4$

(d) $6^{p+1} \times 6^{3p+3}$

(e) $4^6 \div 4^3$

(f) $7^5 \div 7^4$

(g) $y^8 \div y^6$

(h) $2^{3p+3} \div 2^{p-2}$

(i) $(2^3)^4$

(j) $(x^{-3})^{-5}$

(k) $(3^2)^{x-3}$

(l) $(7^{-2})^3$

(m) $5^7 \times 3^4$

(n) $8^1 \times 2^5$

(o) $x^5 y^2$

(p) $6^2 \times 5^2$

6 Simplify where possible:

(a) $x^3 x^2$

(b) $y^7 x^2$

(c) $x^6.2x$

(d) $2^x 3^y$

(e) $2xy(5y^3 + x^4y)$

(f) $2d^2e^5.6d^{-5}e^0$

(g) $a^2b^5c^9 \div a^2b^3c^6$

(h) $\frac{m^6n^{-3} \times mn \times m^5n^{-2}}{m^{12}n^6}$

(i) $\frac{32de^5.d^3e}{4d^{-5}e^6}$

(j) $\frac{m^2.n^{-3}}{m^5.n^7}$

(k) $5^{3x} \div 25x$

(l) $6^x \div 6y$

(m) $13^{2x-1} \div 169x + 6$

(n) $\frac{7^{2a+3b}.11^{-5a+4b}}{7^{a+b}.11^{8a-3b}}$

7 Simplify the following:

(a) $(5^2)^4$

(b) $(6^{-2})^{-3}$

(c) $(7^0)^3$

(d) $[(-5)^3]^5$

(e) $(x^2)^3$

(f) $(3^{x-3})^2$

(g) $\left(\frac{5}{7}\right)^2$

(h) $3^{-2}(3^3 + 3^2)$

(i) $5^5 \div 5^2 \times 5^9$

(j) $\left(\frac{-2a^3b^2}{8a^5b^2}\right)^2$

8 A baby weighs 3,52 kg at birth and his weight increases by an average of 11% per month. What will the baby weigh after one year?

9 A certain radioactive isotope decays half of itself into other elements every day. Initially, there are 20 grams of the isotope. How much of the isotope will be left after 8 days?

10 There are 25 rats in a city sewer.

(a) If the number of rats double every 45 days, how long will it take for the rat population to be 6 400?

(b) If an exterminator exterminates 200 rats per day, how long will it take him to exterminate all the rats? You can assume that no rats are born while he does this.

(c) Which of (a) and (b) is exponential change?

11 Simplify leaving your answer in scientific notation:

(a) $4,243\ 5 \times 10^5 \times 1\ 000$

(b) 10% of $3,689 \times 10^7$

(c) $3.41 \times 10^{21} \times 16\ 000$

(d) $(3 \times 10^8)(2 \times 10^5)$

(e) $\frac{9,324 \times 10^7}{7,733 \times 10^4}$

(f) $5.17 \times 10^{-3} + 3,78 \times 10^{-2}$

12 A neutron weighs 0,000 000 000 000 000 000 000 001 675 kg.

(a) Write the mass of a neutron in scientific notation.

(b) How much will 1 000 neutrons weigh?

(c) How much will 1 000 000 neutrons weigh?

(d) How many neutrons will weigh 1g?

-
- 13 The circumference of the Earth around the Equator is 40 075,16 km.
- (a) How far would you travel if you travel 17 times around the Earth on this path? Express your answer in scientific notation correct to four significant figures.
 - (b) Express the circumference in metres, in centimetres, and in millimetres, giving your values in scientific notation to 3 significant figures.
- 14 Write each of the following numbers in the way requested. Give your answers in scientific notation and state the number of significant figures.
- (a) 8,65 MW in kW
 - (b) 4,65 MW in W
 - (c) 4,3 mA in pA
 - (d) 55 nm in dm
 - (e) 556 cg in g
 - (f) 128 μm in mm
 - (g) 52 kg in TG
 - (h) 88 GHz in MHz
 - (i) 3 679 mg in g
 - (j) 658 ℓ in k ℓ
- 15 Convert the following numbers to the required units.
- (a) Convert 10 000 hectometres to meters.
 - (b) A tank can hold 30 000 ℓ . How many k ℓ will the tank hold if it is only half-full?
 - (d) For each 40 mg of medicine A, a nurse needs to add 250 mL of water. Express this in g/ ℓ .
- 16 Lindiwe decorates a mirror with coloured tiles of 1 cm² each. The mirror is 10 cm in length and 5 cm is breadth.
- (a) How many coloured tiles will she need to cover the mirror?
 - (b) How many cm² is the mirror?
- 17 A construction company removes soil from a building site. Every 2 500 kg soil takes up a volume of 1 m³.
- (a) A large tipper truck can carry 40 tonnes of soil at a time. How many truck trips are needed to remove 1 000 m³ of soil from the site?
 - (b) Express the mass per volume, the density, of soil in g/cm³.
 - (c) If a spade-full of the soil has a volume of 4 litres, how many spadefuls of soil need to be removed?

OPTIONAL Two slightly more realistic real life problems

- 18 Archaeologists often date organic objects, i.e. objects that came from living things, using carbon-14 (C-14) dating techniques. Carbon-14 is a radioactive form of carbon. It is always present in roughly the same concentrations in living things. When the organism dies, the amount of C-14 gradually decreases (as the C-14 breaks down through a nuclear reaction). It takes close to 5 700 years for the amount of C-14 to halve.

An archaeologist has just uncovered the remains of a boat made of oak wood. A technician in a nuclear laboratory analyses a small amount of the wood and discovers that only one eighth of the amount of C-14 in wood from a living oak is present.

- (a) How long ago was the tree, used for the boat, felled?
 - (b) How long ago was the boat made? Is this the same question as in (a)?
 - (c) The same day, the technologist tests another piece of wood (from a different artefact) and finds that it has roughly 60% of the initial amount of C-14 in it. What can you say about the age of the artefact?
 - (d) The next day, a sample from a piece of clothing from another dig arrives at the technician's lab. She finds that it has a third of the initial amount of C-14 in it. What can she say about the age of the clothing?
- 19 In information technology it is sometimes necessary to programme a computer to find a solution to a problem by checking each possible solution.

If the solution is a whole number, between 0 and 9 (including 0 and 9), then the computer has to check ten numbers. If the solution lies between 0 and 99 (inclusive again), then the computer has to test 100 numbers, ten times as many solutions.

Suppose it takes 10^{-9} s for the computer to check one digit.

In a particular problem, the computer has to check for an n -digit solution. It takes the computer 10^{-4} s to do this. Determine the value of n .

4 ALGEBRAIC EXPRESSIONS

This chapter focusses on the algebra of polynomial expressions and quotients of polynomial expressions, also called algebraic fractions.

This chapter will cover the following:

- representing sets, interval notation, set builder notation, number lines
- manipulation of algebraic expressions by adding and subtracting algebraic terms; multiply a binomial by a binomial; multiply a binomial by a trinomial
- determining the highest common factor (HCF) and the lowest common multiple (LCM) of algebraic expressions using factorisation
- factorisation using common factors
- factorisation using grouping in pairs
- factorising quadratic expressions
- factorising expressions involving the difference between two squares
- factorising expressions involving the difference between, and the sum of two cubes
- the use of the lowest common multiple in working with algebraic fractions
- addition and subtraction of algebraic fractions
- multiplication and division of algebraic fractions

4.1 Revision: Notation for representing sets

Mathematical notation is a writing system used for recording concepts in mathematics. The notation uses symbols or symbolic expressions, intended to have a precise meaning.

Examples

Resistor tolerance: A pack of resistors have a resistance of $150\ \Omega$ with a tolerance of 10%. This means that the actual value of the resistance of any one of the resistors will almost certainly lie in the range $150 - 15\ \Omega = 135\ \Omega$ to $150 + 15\ \Omega = 165\ \Omega$.

Engine torque: An engine produces a maximum torque of 2 000 lb-ft. at 7 000 rpm. This means that the torque can have any value in the interval 0 lb-ft. to 2 000 lb-ft.

Coefficient of expansion: Steel railway tracks expand and contract as the temperature increases and decreases. A particular rail has a length of 120 m at 20 degrees Celsius. Its length increases by 0,001% for every degree Celsius change in temperature. If the expected temperature fluctuation is from 10 degrees to 35 degrees Celsius, the length of the rail will vary between $120 - 0,0012\ \text{m} = 119,99\ \text{m}$ to $120 + 0,018\ \text{m} = 120,018\ \text{m}$.

Worked examples

Work through the following examples to refresh your memory:

Problem: If we are asked to represent the following:

A. **Solution:** On a number line

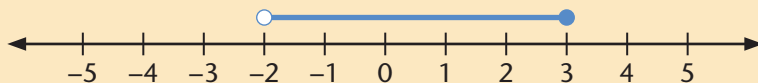

B. **Solution:** In interval notation $x \in (-2; 3]$

C. **Solution:** In set builder notation $\{x \mid -2 < x \leq 3\}$

In this case, our example is an inequality.

Open interval: This is when a number is not included, as in $<$ or $>$, then we use the open dot on the number line.

Closed interval: This is when the number is included, as in \leq or \geq , then we use the closed dot on the number line.

Open interval: When a number is not included, as in $<$ or $>$, then we use $($ or $)$.

Closed interval: This is when the number is included, as in \leq or \geq , then we use $[$ or $]$.

This is read aloud, 'the set of all x such that x is greater than -2 but smaller or equal to 3 '.

In this case, x is the variable and the vertical line $|$ refers to 'such that'.

Exercises

- 1 Represent $3 \leq x < 4$
 - (a) on a number line
 - (b) in interval notation
 - (c) in set builder notation

- 2 Represent $-7 < x \leq 2$
 - (a) on a number line
 - (b) in interval notation
 - (c) in set builder notation

- 3 Represent $x < -9$ or $x > -1$
 - (a) on a number line
 - (b) in interval notation
 - (c) in set builder notation

- 4 Represent each of the following
 - on a number line
 - in interval notation
 - in set builder notation

(a) $-5 \leq x < 1$ (b) $-2 < x$ or $x \leq 3$ (c) $t = 10$
(d) $s > 6$ (e) $m \neq 2$

- 5 Represent the following
 - on a number line and then
 - in interval notation:

(a) $\{t \mid -7 < t \leq 5\}$ (b) $\{m \mid m \leq 2 \text{ or } m > 13\}$

- 6 Represent the following
 - on a number line and then
 - in set builder notation:

(a) $k \in (-\infty; 3]$ (b) $k \in (-\infty; 3] \cup (7; \infty)$

4.2 Using algebraic expressions

This section is about how useful algebraic expressions can be. We will begin with a situation that builds on the revision of equivalent expressions you did in Chapter 1.

Exercise

- 7 Gumani is an expert woodworker. He makes high quality items out of indigenous wood and supplies various shops and markets with these. His most successful items are jewellery boxes made out of wild olive. He has been making them and selling them for a few years but is not yet sure which selling price will make him the best profit. If he charges too little, the boxes will sell very well but his profit will be low. If he charges too much, only a few boxes will sell and he will not make much profit.

The following table shows the different selling prices he has tried and the corresponding number of jewellery boxes he sold:

Selling price in Rand	Number jewellery boxes sold
400	120
450	110
500	100
550	90

- (a) Copy and complete the following sentences in your exercise book:
- (i) For every R50 increase in the selling price, the number sold (increases/decreases) by _____.
 - (ii) For every R10 decrease in the selling price, the number sold (increases/decreases) by _____.
 - (iii) If the selling price is R300, the number sold will be _____.
 - (iv) If the selling price is R100, the number sold will be _____.
 - (v) If the selling price is _____, the number sold will be 200.
 - (vi) If the selling price is _____, the number sold will be 0.
- (b) Gumani comes up with the following rule for calculating the number of jewellery boxes sold:

'200 minus one fifth of the selling price'

Check that Gumani's rule is correct by using it to calculate the values of number of jewellery boxes sold in the table.

What can we learn from the previous exercise?

Gumani's rule for calculating the number of jewellery boxes sold is:

200 minus one fifth of the selling price

If we let the number of jewellery boxes be represented by the letter x , then Gumani's rule for calculating the number of jewellery boxes sold can be written as an algebraic expression as follows:

$$\left(-\frac{1}{5}\right)x + 200.$$

In the representations of Gumani's rule we have the following:

Variables: These are the quantities that can have different values in the situation and in the expression, e.g. the expression $\left(-\frac{1}{5}\right)x + 200$ where x is a variable, the input value of the selling price of the jewellery boxes.

Constants: These are the quantities that have fixed or unchanging values in the situation and the expression, e.g. the expression $\left(-\frac{1}{5}\right)x + 200$ where 200 is a constant.

Operations: These are the ways variables and constants are combined to form new values, e.g. there is multiplication between $-\frac{1}{5}$ and x , and addition between $-\frac{1}{5}$ and 200.

Expression: This is an algebraic 'sentence', 'rule', or 'instruction', e.g. Gumani's rule in algebraic form $\left(-\frac{1}{5}\right)x + 200$ is an algebraic expression.

Terms: These are the parts of an algebraic expression that are added or subtracted, e.g. Gumani's rule has two terms, $-\frac{1}{5}$ and $+200$.

Coefficient: These are constants that are multiplied with variables in a particular term, e.g. $-\frac{1}{5}$ is the coefficient of x in the term $-\frac{1}{5}x$.

When we give the input variable in the expression a value and then use the operations to calculate the value of the output value, we say that we are **evaluating the expression for a particular input**.

The part I divide is called the **dividend** (numerator) and the part I divide with is called the **divisor** (denominator) of the expression:

$$\frac{x^2 + 5x}{x + 5} \rightarrow \frac{\text{dividend}}{\text{divisor}}$$

Exercise Identifying the various expressions

8 Identify the following expressions as they are, as monomial, binomial, or trinomial. Explain whether they are sum, difference, product, or quotient expressions.

- | | | |
|--|-----------------------------|-------------------------|
| (a) x^2 | (b) $1 + x^2$ | (c) $x^2 + x$ |
| (d) $x^2 + x + 1$ | (d) $x^2(x + 1)$ | (e) $\frac{x^2}{x + 1}$ |
| (f) $x(2x + 3)$ | (g) $18 - x(2x + 3)$ | (h) $(2x + 3)(3y + 2)$ |
| (i) $(2x + 3)(3x + 2)$ | (j) $(2x + 3) - (3y + 2)$ | (k) $2x + 3 - 3y + 2$ |
| (l) $2x + 3y + 5$ | (m) $\frac{2x + 3}{3x + 2}$ | (n) $x^3 - 343$ |
| (o) $\frac{x(x + 3)(x - 2)}{x(x + 3)}$ | | |

4.3 Adding and subtracting of algebraic terms

Generally, simplifying an expression involves a number of steps. Each of these steps replaces one expression with another, equivalent expression.

One way of simplifying an algebraic expression that is made up of polynomial terms, is to replace all like terms with single, equivalent terms.

Worked examples

A. Problem:

Add $3x^2 + 5x - 2y + 8$ and $5x^2 + x - 7xy + 4$ into a sum expression by adding and subtracting like terms.

Solution:

$$\begin{aligned} & 3x^2 + 5x - 2y + 8 + 5x^2 + x - 7xy + 4 \\ &= 3x^2 + 5x^2 + 5x + x - 7xy - 2y + 8 + 4 \\ &= 8x^2 + 6x - 7xy - 2y + 12 \end{aligned}$$

B. Problem: Add $r^2 + 3r - 5$ and $7r^2 - 8r - 12$

Solution: $(r^2 + 3r - 5) + (7r^2 - 8r - 12)$

$$\begin{aligned} &= r^2 + 3r - 5 + 7r^2 - 8r - 12 \\ &= r^2 + 7r^2 + 3r - 8r - 12 - 5 \\ &= 8r^2 - 5r - 17 \end{aligned}$$

Both expressions are sum expressions, as the last operation would be to add or subtract.

If: $x = 2$ and $y = 3$ then:

$$\begin{aligned} & 3(2)^2 + 5(2) - 2(3) + 8 + 5(2)^2 + 2 - 7(2)(3) + 4 = 8 \\ & \text{and } 8(2)^2 + 6(2) - 7(2)(3) - 2(3) + 12 = 8 \end{aligned}$$

Therefore, they are equivalent expressions.

Both expressions are sum expressions, as the last operation would be to add or subtract.

If: $r = 2$ then:

$$[(2)^2 + 3(2) - 5 + 7(2)^2 - 8(2) - 12] = 5$$

$$\text{and: } 8(2)^2 - 5(2) - 17 = 5$$

Therefore, they are equivalent expressions.

C. Problem:

Subtract $6x^2 + 5x + 4$ from $10x^2 + 8x + 6$:

Solution: $(10x^2 + 8x + 6) - (6x^2 + 5x + 4)$

$$= 10x^2 + 8x + 6 - 6x^2 - 5x - 4$$

$$= 10x^2 - 6x^2 - 5x + 8x + 6 - 4$$

$$= 4x^2 + 3x + 2$$

Both expressions are sum expressions, as the last operation would be to add or subtract.

If: $x = 2$ then:

$$[10(2)^2 + 8(2) + 6] - [6(2)^2 + 5(2) + 4] = 24$$

$$\text{and: } 4(2)^2 + 3(2) + 2 = 24$$

Therefore, they are equivalent expressions.

Remember, the following **properties of numbers** apply when we multiply:

- a negative multiplied by a negative, equals a positive
- a positive multiplied by a positive, equals a positive
- a negative multiplied by a positive, equals a negative
- a positive multiplied by a negative, equals a negative

$$(-) \times (-) = (+)$$

$$(+) \times (+) = (+)$$

$$(-) \times (+) = (-)$$

$$(+) \times (-) = (-)$$

If I subtract 2 from 6, I write it as $6 - 2$.

We are subtracting the expression $6x^2 + 5x + 4$ from the expression $10x^2 + 8x + 6$. For this reason, we use the brackets and then $-(6x^2 + 5x + 4)$ will become $-6x^2 - 5x - 4$.

Like terms are the terms that have the same letter symbols, with each letter symbol having the same exponent.

Examples

Like terms:

$$3x^2 \text{ and } -0,25x^2; 4mn \text{ and } 3nm; 2(1 - y^2) \text{ and } 7(1 - y^2)$$

Unlike terms:

$$3x^2 \text{ and } 3x; 4m^2n \text{ and } 3n^2m; 2(1 - y^2) \text{ and } 7(3 - y^2)$$

Strategy for using addition or subtraction to simplify a sum expression:

- Group the like terms together.
- Add or subtract the like terms.

We use the **commutative property** of numbers to group like terms together.

Example: $a + b = b + a$ and $a.b = b.a$

We use the **associative property** of numbers to add or subtract like terms.

Example: $(a + b) + c = a + (b + c)$ and $(a.b)c = a(b.c)$.

Exercises

9 Work out the following exercises:

- Simplify $4m^2 + 7m - 2n + 5 - 5m^2 + m + 3mn - 4$. Evaluate the first and the final expressions if $m = 2$ and $n = 3$.
- Add $2x - 5xy + 3y$ and $12x - 2xy - 5y$. Evaluate the given expression and your final expression for $x = 2$ and $y = 3$.
- Subtract $3x^2 - 2x$ from $7x^2 - 4x$. Evaluate the given expression and the final expression if $x = 2$ and $y = 3$.

10 (a) Simplify the following expressions:

- $8m^2n^2 + 5n + 8m^2 - 3m^2n - 3n - 9m^2$
- $3x^2y^2 + 5y^3 + 8x^2 - 2x^2y^2 + 7y - 3x^2$
- $13r^2s^2 + 8s^3 - 2r^2 - 7r^2s^2 + 4s^2 - 8r^2$
- $4r^2s^3 + 8r^2s^3 - 2r^2s^3 - 7r^2s^2 + 12r^2s^2$
- $6t^2u^2 + n^2 + 3k^2l^3 - 3n^2 + 2t^2u^2 + k^2l^3$
- $a^2b^{3c} + f^2g + h^3 - f^2g + a^2b^{3c} + h^3$

(b) Add the following expressions:

- $6x^2 + 5x + 4$ and $10x^2 + 8x + 6$
- $3x^2 - 2x$ and $7x^2 - 4x$
- $4r^2s^3 - 3t^2$ and $3r^2s^3 + 5t^2 + 4$
- $-2p^2 + (-3q^2r^3)$ and $5q^2r^3 - 3p^2$
- $12x^3y - 5z^2$ and $3z^2 + (-4x^3y)$
- $3x^3 - 2x^2 + 4x - 1$ and $-5x^3 + 3x^2 - 7x + 2$

(c) Subtract the following expressions:

- $2r^2 + 3r - 5$ from $7r^2 - 8r - 12$
- $2x - 5xy + 3y$ from $12x - 2xy - 5y$
- $3x^2 - 5x - 7$ from $7x^2 - 2x - 6$
- $4x^2 + 5x - 7$ from $7x^2 - 2x - 6$
- $-2m^3 + 6m + 3m^2$ from $5m - 6m^2 + 7m^3$
- $-2m^2 - 5$ from $-3m^2 - 5$

4.4 Multiplication of polynomials

We can show that the expressions $(x + 1)(x + 2)$ and $x^2 + 3x + 2$ are equivalent by substituting and comparing output values. But how do we know how to compare these two expressions in the first place? Guessing expressions will be a very slow process. We need some way of ‘transforming’ $(x + 1)(x + 2)$ into $x^2 + 3x + 2$:

$$(x + 1)(x + 2) \xrightarrow{\text{What algebraic process?}} x^2 + 3x + 2$$

In paragraph 4.3 we saw how to ‘transform’ additions and subtractions of expressions into equivalent forms.

The operation in $(x + 1)(x + 2)$ is the product, and $(x + 1)$ is multiplied with $(x + 2)$. This is not the same as the multiplication of numbers where we can get a single answer i.e. a single, numerical term. The multiplication of the two binomials here produces three unlike terms, i.e. a quadratic trinomial.

We call the multiplication of expressions, **expansion**. It relies on a well-known characteristic of numbers called the **distributive property**.

Example The distributive property is quite natural

Problem: Multiply 11 by 12 without a calculator

Solution: $11 \times 12 = (10 + 1)(10 + 2)$

$$\begin{aligned} &= 10(10 + 2) + 1(10 + 2) \\ &= 100 + 20 + 10 + 2 \\ &= 132 \end{aligned}$$

Or

$$\begin{aligned} 11 \times 12 &= (11 \times 10) + (11 \times 2) \\ &= 110 + 22 \\ &= 132 \end{aligned}$$

We can see how the distributive property works in expanding $(x + 1)(x + 2)$ by substituting $x = 10$ in $(x + 1)(x + 2)$:

Worked example Using number multiplication to understand expansion

Problem: Find the product of 11 and 12 written as $(10 + 1)$ and $(10 + 2)$.

Solution: Imagine that 11 and 12 are the sides of a rectangle. Then the product of $(10 + 1)$ and $(10 + 2)$ will be the area of the rectangle made up of 132 squares:

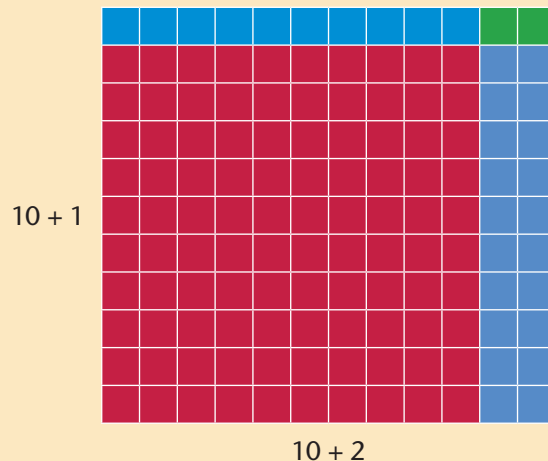

From the diagram, we can see that $(10 + 1)(10 + 2)$ is the same as

$$(10 \times 10) + (10 \times 1) + (10 \times 2) + (1 \times 2)$$

We can focus on the way the four terms arise from the two pairs of terms in the binomial factors by colour coding them differently: $(10 + 1)(10 + 2) = (10 \times 10) + (10 \times 2) + (1 \times 10) + (1 \times 2)$

Exercise Multiplication of monomial expressions by binomial expressions

11 You can use a multiplication grid if you would like to multiply terms with each other.

Draw the following multiplication grid in your exercise book. Complete the blocks by multiplying the number in the top row of the column with the number in the first column to the left:

Multiply:	$2x$	$-9y$
$3y$		
$-5x$		

Now expand the following:

(a) $3y(2x)$

(b) $3y(-9y)$

(c) $3y(2x - 9y)$

(d) $(3y - 5y)(2x - 9y)$

(e) $3y(-5x - 9y)$

(f) $(3y - 5y)(1 - 9y)$

Multiplying binomials by binomials

- $(a + b)(x + y) = (a + b)x + (a + b)y = ax + bx + ay + by$
or alternatively:
- $(a + b)(x + y) = a(x + y) + b(x + y) = ax + ay + bx + by$
- $(a + b)(x - y) = a(x - y) + b(x - y) = ax - ay + bx - by$

Exercise

12 Simplify the following:

- (a) $2x(-x + 1)$ (b) $-10x - x(4 + x)$ (c) $2a + 4b + a(-4 + b)$
(d) $(-x + 1)(-2x - 3)$ (e) $3y - 2x + 2x - 2y$ (f) $-(-x + y) + 2x - 3y$
(g) $\frac{2x + 4x^2}{6x}$

Further examples of multiplying binomial with a binomial

- $(x + y)^2 = x^2 + 2xy + y^2$ Squaring a binomial
- $(x - y)^2 = x^2 - 2xy + y^2$ Squaring a binomial
- $(x + y)(x - y) = x^2 - y^2$ The difference of two squares

Exercise

13 Expand and simplify the following:

- (a) $(3 + q)^2$ (b) $(1 - 3q)^2$
(c) $(3 + q)(3 - q)$ (d) $(1 - 3q)(3 + q)$
(e) $(2x + 5y)^2$ (f) $(2x + 5y)2 - (2x - 5y)^2$
(g) $(2x + 5y)(2x - 5y)$ (h) $(4w + 7)2(4w - 7)$

Multiplying binomials by trinomials

- $(a + b)(x + y + z) = (a + b)x + (a + b)y + (a + b)z = ax + bx + ay + by + az + bz$
or alternatively:
- $(a + b)(x + y + z) = a(x + y + z) + b(x + y + z) = ax + ay + az + bx + by + bz$
- $(a - b)(x - y + z) = (a - b)x - (a - b)y + (a - b)z = ax - bx - ay + by + az - bz$

Exercise

14 Simplify the following:

- (a) $(2x + y)(2a + 3b + c)$ (b) $(a + 3b)(2c + d + 4e)$
(c) $(x + y)(3a - 2b + 3c)$ (d) $(2a + 3b)(4x - 3y + z)$
(e) $(3x + 2y)(3a + 2b + 3c)$ (f) $(2x + 2y)(5d - 3e + f)$

Exercises

15 (a) Expand the following:

(i) $3(x + 1)$

(ii) $x(x + 1)$

(iii) $-x(a + 3)$

(iv) $-a(a - b)$

(b) Simplify:

(i) $2x^2 + 3x(x + 2) - 5x$

(ii) $-2 + (a + b) - a(3 + a)$

(iii) $a(a + 2) - (-3 + a^2)$

(iv) $-a(2a + 2) - 5a(a - 1)$

16 Multiply the following:

(a) $5(3x^2 + 2y)$

(b) $x(x - 3)$

(c) $3x^2(2x + 5y^3)$

(d) $m(3m^2 + 2n - 3)$

(e) $4s^2(3s^3 - 5t + 7)$

(f) $(a + b)(a + b)$

(g) $(3a + b)(3a + b)$

(h) $(a - b)(a - b)$

(i) $(3a - b)(3a - b)$

(j) $(a + b)(a - b)$

(k) $(3a + b)(3a - b)$

(l) $(x + y)(a + b)$

17 Simplify the following expressions:

(a) $x(x^2 + 3x + 4) - x^3 + 2x^2$

(b) $a(a + 2) + 3a^2 - 2a$

(c) $2b(b + 1) + b^2 - b$

(d) $2y(y + 2) - 2y^2 + 3(y + 1)$

(e) $(x + 1)(x^2 + 2x - 3)$

4.5 Factorise expressions of the form $ab \pm ac$

Looking ahead at factorisation, the opposite process to expanding

The process of writing a sum expression (polynomial) as a product is called **factorisation**. This is the *inverse operation of expansion*. Each part of a product is called a **factor of the expression**.

If $c = ab$, then a and b are factors of c .

If $x^2 + 5x + 6 = (x + 2)(x + 3)$, then $x + 2$ and $x + 3$ are factors of $x^2 + 5x + 6$.

How do we take out the Highest Common Factor (HCF) when factorising expressions in the form $ab \pm ac$?

The terms of expressions are also made up by diverse values and variables.

Exercise Explore how to find the HCF

18 Find the highest common factor (HCF). Copy and complete the following table in your exercise book:

	Find for each of the following expressions	$3x + 6y$	$4a^3 + 2a$	$5x + 2x$	$ax^2 - bx^3$	$12a^2b + 18ab^2$
(a)	the factors (excluding 1) of the first term;	3 and x				
(b)	the factors (excluding 1) of the second term;	2; 3 and y				
(c)	the highest common factor of the two terms;	3				
(d)	Write the expression in factor form	$3(x + 2y)$				

Worked example

Problem: Factorise $4x^3 + 2x^2 - 6x$

Solution:

$$\begin{aligned}4x^3 + 2x^2 - 6x &= 2x(2x^2 + x - 3) \\ &= 2x(2x + 3)(x - 1)\end{aligned}$$

Worked examples

Factorise: $(a - b)x + (b - a)y$

$$\begin{aligned}-a + b &= -(a - b) \\ &= (a - b)x - (a - b)y \\ &= (a - b)(x - y)\end{aligned}$$

Note that: $b - a = -a + b$. Now, by taking out -1 as a common factor:

$$\begin{aligned}\text{Factorise: } ac + bc + bd + ad & \\ &= (ac + bc) + (bd + ad) \\ &= c(a + b) + d(b + a) \\ &= (a + b)(c + d)\end{aligned}$$

Order and group terms with common factors.

Take out the common factor.

Write it as a product.

Exercise

19 Factorise the expressions that follow.

(a) $(a - b)x + a - b$

(b) $(a - b)x - a + b$

(c) $xy + x + y + 1$

(d) $(a + b)x - a - b$

(e) $3x(2x - 3) - (3 - 2x)$

(f) $(y^2 - 4y) + (3y - 12)$

(g) $px + py + qx + qy$

(h) $9x^3 - 27x^2 + x - 3$

(i) $4a + 4b + 3ap + 3bp$

(j) $a^4 + a^3 + 3a + 3$

(k) $xy + x - y + 1$

(l) $ac - ad - bc + bd$

Note: It is always a good idea to check factorisation by expanding the answer to ensure that the result is equal to the original expression.

4.6 Factorise expressions of the form $ax^2 \pm bx \pm c$

A trial and error approach to factorising $x^2 \pm bx \pm c$

We can also find factors systematically through trial and error to factorise quadratic trinomials. We saw that quadratic trinomials such as $x^2 + 5x + 6$ are obtained by expanding the product of two linear factors like $(x + 2)(x + 3)$:

$$x^2 + 5x + 6 \begin{array}{c} \xrightarrow{\text{factorisation}} \\ = \\ \xleftarrow{\text{expansion}} \end{array} (x + 2)(x + 3).$$

We know from expanding products that the factors of a quadratic trinomial are two linear binomials. Our problem is simply to find the terms of these binomials. In other words, to get the answer: $x^2 + 5x + 6 = (? + ?)(? + ?)$

We can use a geometric way of understanding this again:

Example Factorising $x^2 + 5x + 6$

Let x take a positive integer value again, say 10 (You can also try this for $x = 1, 2$ etc.). We can represent $x^2 + 5x + 6$ as a collection of squares with sides of length 1 as follows:

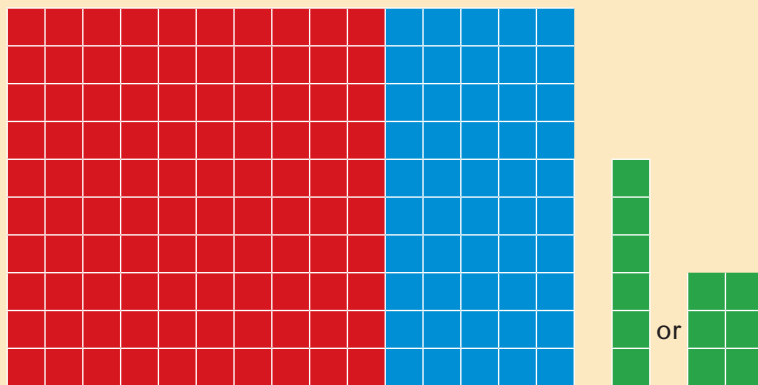

There are:

10² **red** squares corresponding to the term x^2 ,

5.10 **blue** squares corresponding to $5x$, and

6 **green** squares.

There are only two ways that the six squares can be arranged: in 1 by 6 arrangement, or in a 2 by 3 arrangement.

We need to rearrange the squares so that they form a rectangle.

First try: move one blue column of 1 by 10 to the top of the 10 by 10 square:

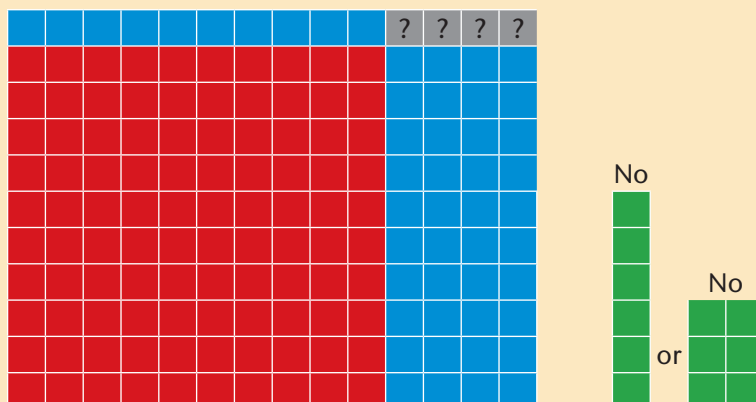

This gives us an 11 by 14 rectangle that is missing four squares, shown in grey. But we need to fit in six green squares, so this rearrangement will not help.

Second Try: move another blue column of 1 by 10 squares to the top:

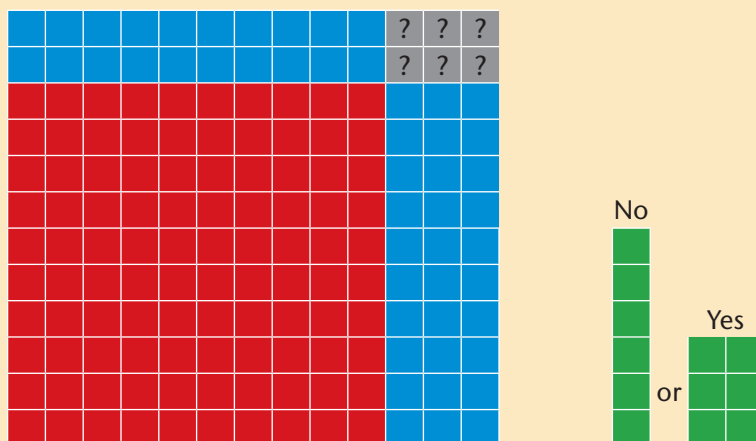

Now we have created a 12 by 13 rectangle that is missing six blocks, exactly the number we need to fit in. So we get:

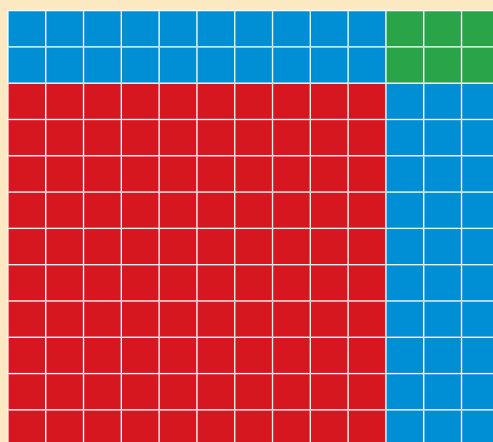

Which we can see is a $(10 + 2)(10 + 3)$ rectangle. Since we let x take the value 10, we can replace the 10 with x again. This means that we have factorised $x^2 + 5x + 6$ to $(x + 2)(x + 3)$.

Exercises Exploring factorisation of trinomials

Copy and complete the following tables in your exercise book.

20 Factorise $x^2 + 6x + 8$.

The factors are of the form $(x \cdot x) + (m + n)x + (m \cdot n)$

(a) Find the possible factor pairs:

If factor $m =$	If factor $n =$	$mn = 8$	$m + n = 6$	Will this work?
+1	+8			Yes/ No
+2	+4			Yes/ No

(b) Hence: $x^2 + 6x + 8 = (x \quad)(x \quad)$

(c) Check your answer by expanding.

(d) Why are both constants in the two factors positive?

21 Factorise $x^2 - 5x + 6$.

The factors are of the form $(x \cdot x) - (m + n)x + (m \cdot n)$

(a) Find the possible factor pairs:

If factor $m =$	If factor $n =$	$mn = 6$	$m + n = -5$	Will this work?
-1	-6			Yes/ No
-2	-3			Yes/ No

(b) Hence: $x^2 - 5x + 6 = (x \quad)(x \quad)$

(c) Check your answer by expanding.

(d) Why are both constants in the two factors negative?

22 Factorise $x^2 + 4x - 12$.

The factors are of the form $(x \cdot x) + (m + n)x - (m \cdot n)$

(a) Find the possible factor pairs:

If factor $m =$	If factor $n =$	$mn = -12$	$m + n = 4$	Will this work?
+12	-1			Yes/ No
+4	-3			Yes/ No
+6	-2			Yes/ No

(b) Hence: $x^2 + 4x - 12 = (x + \quad)(x + \quad)$

(c) Check your answer by expanding.

(d) Why is the one constant positive and the other negative in the two factors?

23 Factorise $x^2 - 4x - 12$.

The factors are of the form $(x \cdot x) - (m + n)x - (m \cdot n)$

(a) Find the possible factor pairs:

If factor $m =$	If factor $n =$	$mn = -12$	$m + n = -4$	Will this work?
+1	-12			Yes/ No
+3	-4			Yes/ No
+2	-6			Yes/ No

(b) Hence: $x^2 - 4x - 12 = (x \quad)(x \quad)$

(c) Check your answer by expanding.

(d) Why is the one constant positive and the other negative in the two factors?

We can summarise what we observed as follows:

The trinomial $x^2 \pm bx \pm c$ rewritten as $(x \cdot x) - (m + n)x - (m \cdot n)$ can be factorised as follows:

Factors will be:	If mn is:	If $m + n$ is:	If $m \neq n$:
$(x + m)(x + n)$	Positive	Positive	Not relevant
$(x - m)(x - n)$	Positive	Negative	Not relevant
$(x + m)(x - n)$	Negative	Positive	$m > n$ because $(m + n) > 0$
$(x + m)(x - n)$	Negative	Negative	$m < n$ because $(m + n) < 0$

Exercise

24 Factorise the following trinomials:

(a) $x^2 + x - 12$

(b) $x^2 - x - 12$

(c) $x^2 + 8x + 12$

(d) $x^2 - 8x + 12$

(e) $x^2 + 9x - 10$

(f) $x^2 - 3x - 10$

(g) $4x - 21 + x^2$

(h) $10x + 21 + x^2$

(i) $x^2 - 18 - 7x$

(j) $x^2 - 20 - 8x$

(k) $x^2 + 2x + 1$

(l) $x^2 - 2x + 1$

(m) $a^2 + 14x + 49$

(n) $p^2 - 16p + 64$

(o) $m^2 + 2mn - 3n^2$

(p) $a^2 - 10ab + 25b^2$

(q) If $x^2 + 3xy - 10y^2$ is the area of a rectangle, and the length is given by the expression $x + 5y$, find the expression for the breadth.

Using HCF and grouping to factorise $x^2 \pm bx \pm c$ expressions

Find factors by splitting the middle term and using the HCF and grouping to factorise quadratic trinomials. How do we do this? We saw that quadratic trinomials such as $x^2 + 5x + 6$ are obtained by expanding the product of two linear factors such as $(x + 2)(x + 3)$:

$$\begin{array}{l} (x + 2)(x + 3) \\ = x(x + 3) + 2(x + 3) \\ = x^2 + 3x + 2x + 6 \\ = x^2 + 5x + 6 \end{array}$$

expansion factorisation

We can factorise expressions such as $x^2 + 5x + 6$ by simply reversing this process. This is done by writing the middle term ($5x$) as the sum of two terms ($2x$ and $3x$) such that the sum of their coefficients is 5 and their product is 6.

Coefficient is a number or symbol multiplied with a variable or an unknown quantity in an algebraic term. For example, 4 is the coefficient in the term $4x$, and x is the coefficient in $x(a + b)$.

Worked examples

Factorise:

$$\begin{aligned} &x^2 + 4x + 3 \\ &= x^2 + x + 3x + 1 \\ &= x(x + 1) + 3(x + 1) \\ &= (x + 1)(x + 3) \end{aligned}$$

If the two factors are +3 and +1 then the constant c will be $(+3) \times (+1) = +3$ and the coefficient b of x will be $(+3) + (+1) = +4$.
Rewriting the middle term as $\pm mx \pm nx$.
Grouping and taking out the HCF.
Write it as a product.

Factorise:

$$\begin{aligned} &x^2 + 3x - 4 \\ &= x^2 - x + 4x - 4 \\ &= x(x - 1) + 4(x - 1) \\ &= (x - 1)(x + 4) \end{aligned}$$

If the two factors are +4 and -1 then the constant c will be $(+4) \times (-1) = -4$ and the coefficient b of x will be $(+4) + (-1) = +3$.
Rewriting the middle term as $\pm mx \pm nx$.
Grouping and taking out the HCF.
Write it as a product.

Exercises

25 Factorise the following trinomials:

(a) $a^2 + 9a + 14$

(b) $x^2 + 3x - 18$

Remember to check your answer by expanding the factors to test if you do get the original expression. Share the way you solve the problem with the rest of the class.

26 Factorise the following trinomials:

(a) $a^2 + 9a + 14$

(b) $x^2 + 3x - 18$

(c) $x^2 - 18x + 17$

(d) $y^2 + 20y + 30$

(e) $y^2 - 13y - 30$

(f) $y^2 + 7y - 30$

(g) $x^2 + 2x - 15$

(h) $m^2 + 4m - 21$

(i) $x^2 - 4x + 9$

(j) $b^2 + 15b + 56$

(k) $a^2 - 2a - 36$

(l) $a^2 - ab - 30b^2$

(m) $x^2 - 5xy - 24y^2$

(n) $x^2 - 13x + 40$

(Remember to check your answer by expanding the factors to test if you do get the original expression.)

27 Factorise the following trinomials:

(a) $2a^2 + 9a + 9$

(b) $3x^2 + 3x - 6$

(Remember to check your answer by expanding the factors to test if you do get the original expression.)

28 (a) How are the trinomials in Exercise 27 different to the trinomials in Exercises 25 and 26?

(b) Are you still able to use the strategy as before?

Explain your answer.

(c) Is there a way that one can adapt our current strategy to work for these types of trinomials?

Factorise expressions of the form $ax^2 \pm bx \pm c$

As noted in the last Exercise, the challenge is to factorise trinomials with a coefficient of x^2 other than 1. In this lesson, we are going to explore how we can adjust our strategy to achieve this goal.

Exercise It was there all the time

29 Consider the trinomial $x^2 + 9x + 14$. Compare this with the standard form $ax^2 \pm bx \pm c$ and answer the following questions:

- (a) What value will the constant c be in the trinomial?
- (b) What value will the coefficient b be in the trinomial?
- (c) What value will the coefficient a be in the trinomial?

In Algebraic notation, if the coefficient is 1, we do not write that in front of the variable. If the coefficient is -1 we just write the $-$ in front of the variable.

Worked example

Factorise:

$$\begin{aligned}x^2 + 9x + 14 \\&= x^2 + 7x + 2x + 14 \\&= x(x + 7) + 2(x + 7) \\&= (x + 7)(x + 2)\end{aligned}$$

If the two factors are $+7$ and $+2$ then the constant c will be $(+7) \times (+2) = +14$ and the coefficient ' b ' of x will be $(+7) + (+2) = +9$.
Rewriting the middle term as $\pm mx \pm nx$.
Grouping and taking out the HCF.
Write it as a product.

Exercise

- 30 (a) Consider the following: If we rewrite the middle term as two terms, using two factors that were obtained as follows:
- We multiply the coefficient ' a ' with the coefficient c .
 - We find two factors (m and n) of this product, if added together, will give us the coefficient b . ($\therefore m + n = b$ and $m \times n = a \times c$)
 - We then use these two factors to rewrite the middle term and proceed to take out the HCF to factorise the trinomial.
- (b) Test it by factorising $x^2 + 9x + 14$ again.
- (c) Do you think it changed anything?
- (d) Now test the strategy by factorising the problem: $2a^2 + 9a + 9$

Worked examples

Factorise:

$$\begin{aligned}3x^2 + 3x - 6 \\&= 3x^2 - 3x + 6x - 6 \\&= 3x(x - 1) + 6(x - 1) \\&= (x - 1)(3x + 6)\end{aligned}$$

If the two factors are -3 and $+6$ then the coefficient of x will be $(-3) + (+6) = +3$.
Rewriting the middle term as $\pm mn \pm nx$.
Grouping and taking out the HCF.
Write it as a product.

Exercises Practicing your new strategy

31 Factorise the following trinomials (remember to check your answer by expanding the factors to test if you do get the original expression):

(a) $5a^2 + 27a + 10$

(b) $3x^2 - 5x - 12$

(c) $24x^2 - 14x - 3$

(d) $15y^2 - 11y + 2$

(e) $14y^2 - 25y - 25$

(f) $12y^2 - 13y - 35$

(g) $6x^2 - 14x - 12$

(h) $21m^2 - 6 - 15m$

(i) $24x^2 - 30x + 8 + 2x$

(j) $24b^2 - 46b - 18$

32 Now factorise the following, try your best to do it:

(a) $x^2 - 9$

(b) $x^2 - 16$

33 Did you struggle to answer the two problems in Exercise 32? Let us consider factorising $x^2 - y^2$.

(a) Do you think we can rewrite this binomial as the trinomial $x^2 + 0xy - y^2$?

(Is $x^2 + 0xy - y^2$ and $x^2 - y^2$ the same?)

(b) Now rather factorise $x^2 + 0xy - y^2$

It does not mean if you cannot see $0x$ that it does not exist!

Remember: The factors are of the form

$$(x \cdot x) - (m + n)x - (m \cdot n) = (x + m)(x - n)$$

(c) Check your answer by expanding it.

4.7 Factorising the difference of two squares

In the following lesson, we are going to explore the problem that you did in the previous Exercise. We are going to consider how we can factorise the difference of two squares.

An expression of the form $a^2 - b^2 = (a + b)(a - b)$ is called the difference of two squares.

Exercise Exploring factorisation of the difference of two squares

34 For this Exercise, you will need paper, scissors, a ruler, and a straightedge.

Step 1: Use a straightedge to draw two squares similar to those shown below. Choose any measure for a and b .

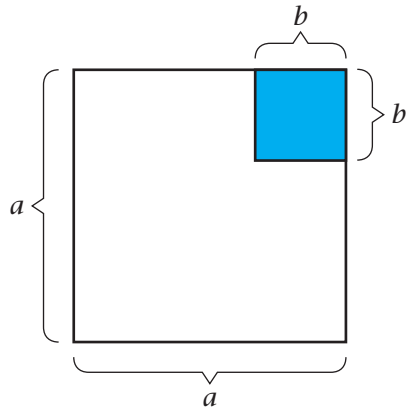

Step 2: Cut the small square from the large square.

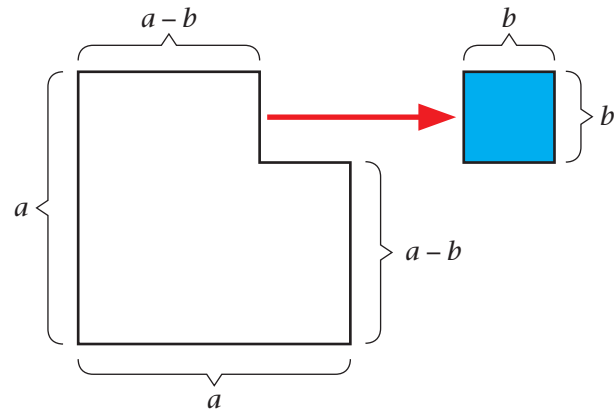

(a) What is the area of the large square in terms of a , and what is the area of the small square in terms of b ?

(b) Can you agree with the statement that the area of the remaining irregular region is $a^2 - b^2$?

Step 3: Cut the irregular region into two congruent pieces as shown below:

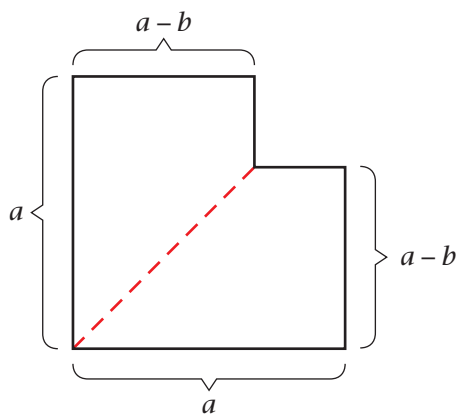

Step 4: Rearrange the two congruent regions to form a rectangle as shown below:

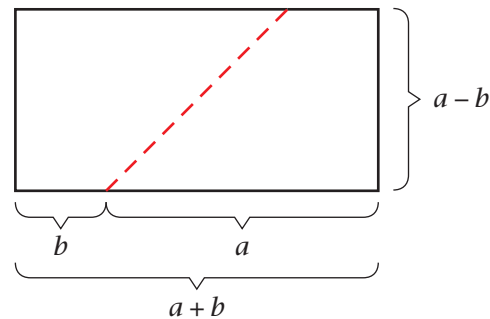

(c) Write an expression representing the area of the new rectangle made in step 4.

(d) Explain why $a^2 - b^2 = (a + b)(a - b)$

Challenge: Another way to show the factorisation of the difference of two squares is to use an approach more like the example at the start of 4.6. Do this with a 5 by 5 square from which a 3 by 3 square is removed from one corner. Shade the four zones differently to keep track.

Worked example Factorise $9x^4 - 4y^2$

To factorise a difference between squares, we use the identity: $a^2 - b^2 = (a + b)(a - b)$ where a and b represent numbers or algebraic expressions.

Stated differently: If p and q are perfect squares, also ‘algebraic squares’, then:

$$p^2 - q^2 = (p + q)(p - q)$$

$$\begin{aligned} 9x^4 - 4y^2 &= (3x^2)^2 - (2y)^2 \\ &= (3x^2 + 2y)(3x^2 - 2y) \end{aligned}$$

Exercises

35 Factorise the following expressions:

(a) $9a^2 - b^2$

(b) $18a^2 - 2b^2$

(c) $a^2 - 1$

(d) $9a^4 - b^6$

Remember: Always take out the highest common factor, if there is one, before you try to factorise the expression (see b).

One is a perfect square: $1 = 1^2$ as $1^m = 1$ (see c)

36 Use the skills you learnt to factorise the following:

(a) $4a^2 - b^2$

(b) $m^2 - 9n^2$

(c) $25x^2 - 36y^2$

(d) $121x^2 - 144y^2$

(e) $16p^2 - 49q^2$

(f) $64a^2 - 25b^2c^2$

(g) $x^2 - 4$

(h) $16x^2 - 36y^2$

(i) $1 - a^2b^2c^2$

(j) $25x^{10} - 49y^8$

(k) $2x^2 - 18$

(l) $200 - 2b^2$

(m) $3xy^2 - 48xa^2$

(n) $5a^4 - 20b^2$

37 Is it possible to factorise the sum of two squares? Try to determine the algebraic factors of $m^2 + n^2$. Show that your factorised expression is equivalent to $m^2 + n^2$ either by

- Expanding it again algebraically to get $m^2 + n^2$, or
- By substituting some values of m and n to show that the expressions produce the same outputs for the same inputs

(Hint: Your options are very few. Your factors have to be two binomials containing m and n .)

4.8 Factorising: addition or subtraction of two cubes

The other two special factoring formulas are two sides of the same coin: the sum and difference of cubes. These are the formulas:

- $a^3 + b^3 = (a + b)(a^2 - ab + b^2)$ and
- $a^3 - b^3 = (a - b)(a^2 + ab + b^2)$

Exercises Exploring addition and subtraction of two cubes

38 Expand the following:

(a) $(x + y)(x^2 - xy + y^2)$

(b) $(x - y)(x^2 + xy + y^2)$

(c) $(x + 2y)(x^2 - 2xy + 4y^2)$

(d) $(x - 2y)(x^2 + 2xy + 4y^2)$

(e) $(2x + y)(4x^2 - 2xy + y^2)$

(f) $(x - 2y)(x^2 + 2xy + 4y^2)$

(g) $(3x + 2y)(9x^2 - 6xy + 4y^2)$

(h) $(3x - 2y)(9x^2 + 6xy + 4y^2)$

The pattern that emerges

The sum of and difference between two cubes are equivalent to the product of a binomial and a trinomial:

$$a^3 + b^3 = (a + b)(a^2 - ab + b^2)$$

$$a^3 - b^3 = (a - b)(a^2 + ab + b^2)$$

Notice that the operation + or - in the binomial factor is the same as the operation in the two cubes expression. The operation of the product term in the trinomial factor is the opposite of the one in the two cubes expression.

Worked example

Problem: Factorise $125x^3 - 1$

Solution:

Step 1: Notice that $125x^3$ and 1 are both perfect cubes. Rewrite the binomial as the difference between two cubes:

$$125x^3 - 1 = (5x)^3 - 1^3$$

Step 2: Determine the binomial factor and then the trinomial factor:

$$\begin{aligned}(5x)^3 - 1^3 &= (5x - 1)(? + ?? + ???) \\ &= (5x - 1)((5x)^2 + (5x)(1) + 1^2) \\ &= (5x - 1)(25x^2 + 5x + 1)\end{aligned}$$

Worked example

Problem: Factorise $27 + \frac{p^6}{8}$

Solution:

Step 1: Notice that $27 = 3^3$ and that $\frac{p^6}{8} = \left(\frac{p^2}{2}\right)^3$

Step 2: Factorise

$$\begin{aligned}27 + \frac{p^6}{8} &= 3^3 + \left(\frac{p^2}{2}\right)^3 \\ &= \left(\frac{3+p^2}{2}\right)\left((3)^2 - (3)\left(\frac{p^2}{2}\right) + \left(\frac{p^2}{2}\right)^2\right) \\ &= \left(3 + \frac{p}{2}\right)\left(9 - \left(\frac{3}{2}\right)p^2 + \frac{p^4}{4}\right)\end{aligned}$$

A useful mnemonic

Some people use the mnemonic ‘SOAP’ for the signs; the letters stand for ‘same’ as the sign in the middle of the original expression, ‘opposite’ sign, and ‘always positive’.

$$a^3 \pm b^3 = a \text{ [same sign]} ba^2 \text{ [opposite sign]} ab \text{ [always positive]} b^2$$

The quadratic part of each cube formula does not factor, so don’t attempt it.

A mnemonic is a way of easily remembering something that is tricky to do.

Mnemonics are great because of this. They are however, also dangerous, because mnemonics avoid dealing with the tricky details, so you have to trust that the mnemonic is telling you to do the right thing.

Exercise

39 Use the skills you learnt to factorise the following:

- | | |
|--------------------------------------|-----------------------------|
| (a) $1 - 8x^6$ | (b) $8m^9 - 1$ |
| (c) $8a^3 - b^3$ | (d) $x^9 - 27y^3$ |
| (e) $125p^{12} - 216$ | (f) $1 + \frac{64}{t^{15}}$ |
| (g) $3x^3b - 24b$ | (h) $x^3 + 343x^6$ |
| (i) $m^3 + 64n^3$ | (j) $16a^3 - 2b^3$ |
| (k) $\frac{1\,000}{1\,331} + 216y^6$ | |

Remember:

Always take out the highest common factor if there is one before you try to factorise the expression.

One is a perfect cube: $1 = 1^3$ as $1^m = 1$

4.9 Factorising: some mixed examples

Exercises

40 Factorise the following expression completely:

(a) $2(3x^2 - 7x - 6)$

(b) $7m^2 - 2 - 5m$

(c) $12x^2 - 16x + 4 + 2x$

(d) $24b^2x - 46bx - 18x$

(e) $36x^2 - 49y^2$

(f) $72ax^2 - 24ay^2$

(g) $125p^{12} + 8x^6$

(h) $32a^4b - 4ab^4$

(i) $5a^2 + 27a + 10 + 4a^2 - b^2$

(j) $3x^2 - 5x - 12 + 8a^3 - b^3$

(k) $2x^2 - 18 + 5a^4 - 20b^2$

(l) $x^2 - 4 + 16a^3 - 2b^3$

(m) $14y^2 - 25y - 25 + m^3 + 64n^3$

(n) $12y^2 - 13y - 35 + m^2 - 9n^2$

41 In each case, calculate the area of the shaded part without using your calculator.

(a)

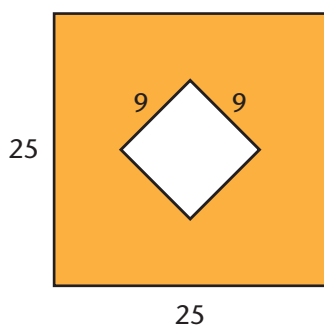

(b)

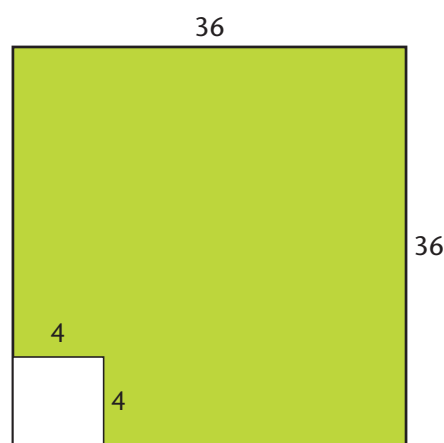

4.10 Simplifying algebraic fractions (quotient expressions)

By the end of this lesson, you will know what an algebraic fraction is, and you will be able to simplify algebraic fractions using factorisation and the property $\frac{ax}{a} = x$ if $a \neq 0$.

In the case of the expression $\frac{x^2 + 5x + 6}{x + 2}$
the numerator $(x^2 + 5x + 6)$ is the **dividend**,
the denominator $(x + 2)$ is the **divisor**
and the simplified form $(x + 3)$ is the **quotient**.

Exercise Quotient expressions

42 (a) Copy and complete the following diagram in your workbook.

Calculate $\frac{x^2 + 5x + 6}{x + 2}$ for $x = 2$:

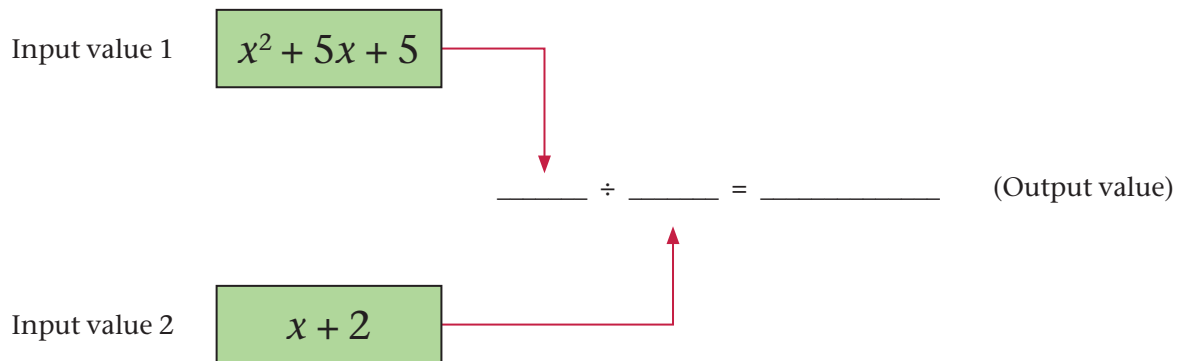

(b) What is the last step of your calculation (addition, subtraction, multiplication, or division)?

It is important to note that if $x + 2 = 0$ ($\therefore x = -2$) then $\frac{x^2 + 5x + 6}{x + 2}$ will not be possible as division by zero does not make sense.

Worked example

Simplify

$$\begin{aligned} & \frac{x^2 + 5x + 6}{x + 2} \\ &= \frac{(x + 2)(x + 3)}{x + 2} \\ &= x + 3 \text{ if } x \neq -2 \end{aligned}$$

We use factorisation to rewrite the numerator or the denominator into its factors. We then use the property $\frac{ax}{a} = x$ if $a \neq 0$ to simplify the term of the algebraic fraction.

Exercises Let's practise

43 Simplify the following algebraic fractions (remember to list the excluded values of the variables):

(a) $\frac{6x^2 + 2}{2x}$

(b) $\frac{x^2 + 8x + 15}{x + 5}$

(c) $\frac{x^2 - 6x + 8}{x^2 - 16}$

(d) $\frac{x^2 - 9}{2x - 6}$

(e) $\frac{2x^2y \times 3xy^2}{4xy}$

(f) $\frac{a^2 + ab}{b^2 + ab}$

(g) $\frac{2x^3 - 4x^2 + x - 2}{(x + 1)(x - 2)}$

(h) $\frac{a^3 - b^3}{a^2 + ab + b^2}$

44 Where possible, simplify the following algebraic fractions and list the excluded values of the variables:

(a) $\frac{10y^2 - 5y}{5y}$

(b) $\frac{9x^2 - 3xy^2 + 6xy}{3xy}$

(c) $\frac{a^2 + ab}{a^2 - ab}$

(d) $\frac{r + r^2}{s + rs}$

(e) $\frac{x^2 - y^2}{(x - y)^2}$

(f) $\frac{a^2 + ab - 2b^2}{a^2 - 2ab + b^2}$

(g) $\frac{4x^2 - 9}{4x^2 - 6x}$

(h) $\frac{x^2 - 3x - 4}{x^2 - 16}$

(i) $\frac{x^2 + 5x - 6}{x^2 + 5x + 6}$

(j) $\frac{m^2 - m - 6}{m - 3}$

(k) $\frac{x^3 - y^3}{x^2 + xy + y^2}$

(l) $\frac{m^2 - 2mn + n}{m^3 + n^3}$

4.11 Lowest common multiples (LCM) and highest common factors (HCF)

LCM – when finding the LCM of algebraic terms we take the variables with the highest exponents.

Example 1: For ab ; a^2bc ; ab^3 we have a LCM of a^2b^3c

Example 2: For $2x^2$; $4x^3y$; $3x^4y^3z$ we have a LCM of $12x^4y^3z$

HCF – when finding the HCF of algebraic terms we take common variables with the lowest exponents.

Example 1: For ab ; a^2bc ; ab^3 we have a HCF of ab

Example 2: For $2x^2$; $4x^3y$; $3x^4y^3z$ we have a HCF of x^2

4.12 Adding and subtracting algebraic fractions

Let us practice how to write equivalent fractions by using the Lowest Common Multiple (LCM) and, add and subtract algebraic fractions that do not require factorisation.

Hint: To add or subtract fractions, the denominators need to be the same. We need to rewrite the fractions as equivalent fractions with the same denominator.

Exercise Practise using LCM

45 Add or subtract the following fractions:

(a) $\frac{2}{3} + \frac{1}{4}$

(b) $\frac{2}{5} - \frac{1}{4}$

(c) $\frac{a}{3} + \frac{b}{4}$

(d) $\frac{2}{a} + \frac{1}{b}$

(e) $\frac{3}{2} - \frac{7}{9}$

(f) $\frac{m}{n} - \frac{2}{3}$

(g) $\frac{5y}{2} - \frac{3z}{3}$

(h) $\frac{2}{xy} - \frac{3}{5}$

Worked examples

Study the following worked examples to find the Lowest Common Multiple (LCM):

A. **Problem:** Find the LCM of 8 and 20

Solution: $8 = 2 \times 2 \times 2$

$$20 = 2 \times 2 \times 5$$

Common factors 2×2

$$\text{LCM } 2 \times 2 \times 2 \times 5 = 40$$

Write the terms in their prime factors.

Find the factors common to each.

Find the factors left for each term.

Additional factors 2 (from 8) and 5 (from 20).

Multiply the common.

B. **Problem:** Find the LCM of x^3y^2 and x^2y^4

Solution: Variables $x; y$

Highest degree $x^3; y^4$

$$\text{LCM } x^3y^4$$

List the variable in all terms.

List each variable with the highest exponent.

Multiply the highest degree variables.

C. **Problem:** Find the LCM of $8x^3y^2$ and $20x^2y^4$

Solution: $\text{LCM } 2 \times 2 \times 2 \times 5 \times x^3y^4 = 40x^3y^4$

Just follow the process as before for the coefficients and the variables.

Multiplying with 1:

If we multiply a number by one, it always stays the same: $x \times 1 = x$

To add or subtract fractions, the denominators need to be the same. Multiplying each term of the algebraic fraction by $\frac{\text{LCM}}{\text{LCM}}$ we rewrite the terms as equivalent fractions with the same denominator.

$\frac{1}{2} \times \frac{5}{5} = \frac{5}{10}$ because $\frac{5}{5} = 1$ therefore $\frac{1}{2}$ and $\frac{5}{10}$ are equivalent fractions.

The same will apply to $\frac{1}{a} \times \frac{b}{b} = \frac{b}{ab}$

Worked example

Problem: Simplify $\frac{a}{2b} + \frac{b}{3a} - \frac{a^2 + 2b^2}{6ab}$

Solution: LCM $2 \times 3 \times a \times b = 6ab$

$$\frac{a}{2b} + \frac{b}{3a} - \frac{a^2 + 2b^2}{6ab}$$

We multiply each term by $\frac{\text{LCM}}{\text{LCM}}$

$$= \left(\frac{a}{2b} \times \frac{6ab}{6ab} \right) + \left(\frac{b}{3a} \times \frac{6ab}{6ab} \right) - \left(\frac{a^2 + 2b^2}{6ab} \times \frac{6ab}{6ab} \right)$$

$$= \frac{3a^2}{6ab} + \frac{2b^2}{6ab} - \frac{a^2 + 2b^2}{6ab} \quad \text{Use the property } \frac{A \times C}{B \times C} = \frac{A}{B} \text{ if } B \neq 0 \text{ and } C \neq 0 \text{ to simplify.}$$

$$= \frac{3a^2 + 2b^2 - (a^2 + 2b^2)}{6ab} \quad \text{Simplify brackets}$$

$$= \frac{3a^2 + 2b^2 - a^2 - 2b^2}{6ab} \quad \text{Add like terms}$$

$$= \frac{2a^2}{6ab} \quad \text{Use the property } \frac{ax}{a} = x \text{ if } a \neq 0 \text{ to simplify the algebraic fraction}$$

$$= \frac{a}{3b} \text{ if } a \neq 0 \text{ or } b \neq 0$$

Exercise

46 Where possible, simplify the following algebraic fractions and list the excluded values of the variables:

(a) $\frac{a+1}{2} - \frac{(a-1)}{3}$

(b) $x - \frac{x-y}{2}$

(c) $\frac{2a}{3} + \frac{4a-1}{5} + a$

(d) $\frac{1}{a} + \frac{1}{b} + \frac{1}{c}$

(e) $\frac{2a+b}{b} - \frac{a-b}{a}$

(f) $\frac{2a+b}{a} - \frac{a-b}{b}$

(g) $1 - \frac{a+b}{2a} - \frac{a-b}{3a}$

(h) $\frac{a+1}{ab} + \frac{c-1}{bc}$

(i) $\frac{x+3}{x^2y} - \frac{y-3}{xy^2}$

(j) $\frac{2k-3}{6km} - \frac{3m+2}{9m^2}$

(k) $\frac{x+1}{3x^2} - \frac{x+1}{4x^4} + \frac{x+1}{5x^5}$

(l) $\frac{3a+b}{a^2b} + \frac{a-4b}{a^2b^2} - \frac{a^2+b^2}{a^3b^2}$

Factorising is an important skill in dealing with algebraic expression. Finding the LCM of two terms is also important. From this reason we will do a bit of revision of these skills first:

Exercise

47 Find the Lowest Common Multiple (LCM) of the following expressions:

- (a) $(x^2 + 5x + 6)$ and $(2x^2 + 7x + 6)$ (b) $(x^2 + x - 6)$ and $(x^2 - 8x + 12)$
(c) $(3x - 6y)$ and $(mx - 2my)$ (d) $(mx + my)$ and $(nx + ny)$
(e) $(ax + 2a)$ and $(bx + 2x)$ (f) $(7a + 21b)$ and $(4a + 12b)$
(g) $(3x + 3y)$ and $(7x + 7y)$ (h) $(9ax^2 + 9bx^2)$ and $(ay^2 + by^2)$

Hint: Before we can find the LCM, we first need to factorise the expressions.

Worked examples

A. **Problem:** Simplify $\frac{6}{3x + 6y} + \frac{3}{2x + 4y}$

Solution:

$$\begin{aligned} & \frac{6}{3x + 6y} + \frac{3}{2x + 4y} \\ &= \frac{6}{3(x + 2y)} + \frac{3}{2(x + 2y)} \\ &= \frac{2}{(x + 2y)} + \frac{3}{2(x + 2y)} \end{aligned}$$

First take out the common factors.

Use the property $\frac{ax}{a} = x$ if $a \neq 0$ to simplify each fraction

$$\text{LCM } 2 \times (x + 2y) = 2(x + 2y).$$

$$= \left(\frac{2}{(x + 2y)} \times \frac{2(x + 2y)}{2(x + 2y)} \right) + \left(\frac{3}{2(x + 2y)} \times \frac{2(x + 2y)}{2(x + 2y)} \right) \quad \text{We multiply each term by } \frac{\text{LCM}}{\text{LCM}}$$

Use the property $\frac{A \times B}{B \times C} = \frac{A}{C}$ if $B \neq 0$ and $C \neq 0$ to simplify algebraic fractions.

Note the use of the brackets.

$$= \frac{4}{2(x + 2y)} + \frac{3}{2(x + 2y)}$$

Use the property $\frac{ax}{a} = x$ if $a \neq 0$ to simplify each fraction.

$$= \frac{4 + 3}{2(x + 2y)}$$

$$= \frac{7}{2(x + 2y)} \text{ if } x \neq 0 \text{ or } y \neq 0$$

Remember the exponential laws:

$$a^m \times a^n = a^{m+n}$$

$$a^m \div a^n = a^{m-n}$$

B. Problem: Simplify $\frac{ax}{ax^2 + axy} + \frac{2ax + 2bx}{3(y + x)(a + b)}$

Solution: First take out the common factors.

$$\begin{aligned} & \frac{ax}{ax^2 + axy} + \frac{2ax + 2bx}{3(x + y)(a + b)} \\ &= \frac{ax}{ax(x + y)} + \frac{2x(a + b)}{3(x + y)(a + b)} \\ &= \frac{1}{(x + y)} + \frac{2x}{3(x + y)} \end{aligned}$$

LCM $3 \times (x + y) = 3(x + y)$.

$$\begin{aligned} &= \left(\frac{1}{(x + y)} \times \frac{3(x + y)}{3(x + y)} \right) + \left(\frac{2x}{3(x + y)} \times \frac{3(x + y)}{3(x + y)} \right) \quad \text{We multiply each term by } \frac{\text{LCM}}{\text{LCM}} \\ &= \frac{3}{3(x + y)} + \frac{2x}{3(x + y)} \\ &= \frac{3 + 2x}{3(x + y)} \end{aligned}$$

Exercise Practise what you learnt

48 Where possible, simplify the following algebraic fractions and list the excluded values of the variables:

(a) $\frac{12}{6x + 6y} + \frac{1}{2x + 2y}$

(c) $\frac{r + r^2}{s + sr} - \frac{r^2 + sr}{r^2 - sr}$

(e) $\frac{x + 1}{(a - b)x + a - b} - \frac{4(y - 1)}{(a - b)y - 2a + 2b}$

(g) $\frac{3x + 3}{xy + x + y + 1} + \frac{(y^2 - 4y) + (3y - 12)}{2y - 8}$

(i) $\frac{2x + 2y + 6}{(x + y)^2 + 3(x + y)} - \frac{3x}{x^2 + xy}$

(k) $\frac{x^2 - y^2}{3x + 3y} + \frac{3ay - 3a}{xy - y}$

(b) $\frac{bx^2}{bx^3 + bx^2y} + \frac{2ax + 2bx}{4(b - a)(a + b)}$

(d) $\frac{x}{a + b} + \frac{a - b}{bx - ax}$

(f) $\frac{3x(2x - 3) - (3 - 2x)}{3 - 2x} - \frac{18x^3}{9x^3 - 27x^2 + x - 3}$

(h) $\frac{2ab + 2b^2}{x(a + b) + y(b - a)} + \frac{x - y}{x + y}$

(j) $\frac{10x^2y^3 + 20x^3y^2}{50x^2y^2} + \frac{x + y}{x - y}$

(l) $\frac{x^2 - y^2}{x^2 - 2xy + y^2} - \frac{x + y}{y - x}$

Worked example

Problem: Simplify $\frac{x+3}{x^2-2x-15} - \frac{x-7}{x^2-4x-21}$

Solution:

$$\begin{aligned} & \frac{x+3}{(x+3)(x-5)} - \frac{x-7}{(x+3)(x-7)} \\ &= \frac{1}{x-5} - \frac{1}{x+3} \\ &= \left(\frac{1}{x-5} \times \frac{(x-5)(x+3)}{(x-5)(x+3)} \right) - \left(\frac{1}{x+3} \times \frac{(x-5)(x+3)}{(x-5)(x+3)} \right) \\ &= \frac{x+3}{(x-5)(x+3)} - \frac{(x-5)}{(x-5)(x+3)} \\ &= \frac{x+3-(x-5)}{(x-5)(x+3)} \\ &= \frac{x+3-x+5}{(x-5)(x+3)} \\ &= \frac{8}{(x-5)(x+3)} \end{aligned}$$

Exercise

49 Where possible, simplify the following algebraic fractions and list the excluded values of the variables:

(a) $\frac{x-3}{x^2-2x-15} - \frac{x-7}{x^2-4x-21}$

(b) $\frac{x-1}{2x+3} + \frac{x+2}{x^2-9x-22}$

(c) $\frac{x+2}{3x-2} + \frac{x^2+15x+56}{x+7}$

(d) $\frac{x^2+12x+35}{x^2+4x-5} - \frac{2x^2-9x-5}{x^2+4x-5}$

(e) $\frac{3xy+6y}{x^2+5x+6} - \frac{2xy-4y}{x^2+2x-8}$

(f) $\frac{x^2+5x}{x^2-5x-50} + \frac{x^3-x^2-30x}{3x^2+18x}$

(g) $\frac{x^2-16x+15}{x^2-13x-30} + \frac{2x+3}{2x^2+5x+3}$

(h) $\frac{x^2-4}{3x-6} - \frac{x+7}{x^2+15x+56}$

(i) $\frac{x^2-y^2}{3x^2+3xy} - \frac{5x+4y}{25x^2-16y^2}$

(j) $\frac{x^2-xy+y^2}{x^3+y^3} + \frac{y+1}{x-1}$

(k) $\frac{x^2+xy+y^2}{3ax^3-3ay^3} + \frac{x+1}{x^2-1}$

(l) $\frac{6ax^3-6ay^3}{2a^2x^2+2a^2xy+2a^2y^2} - \frac{x-1}{y-x}$

4.13 Multiplying algebraic fractions

Multiplying simple algebraic fractions

Using the property $\frac{a}{b} \times \frac{x}{y} = \frac{ax}{by}$ if $b \neq 0$ and $y \neq 0$ to multiply algebraic fractions that do not require factorisation.

Exercises Multiplying algebraic fractions

50 Complete the calculations:

(a) $\frac{3}{5} \times \frac{2}{3}$

(b) $\frac{1}{3} \times \frac{6}{7}$

(c) $\frac{9}{4} \times \frac{3}{5}$

(d) $\frac{11}{5} \times \frac{9}{3}$

51 Now, try to simplify the following algebraic fractions:

(a) $\frac{a^2}{3} \times \frac{6}{a}$

(b) $\frac{a^2}{a} \times \frac{6}{3}$

(c) $\frac{b^3}{ab} \times \frac{a^2}{b}$

(d) $\frac{5c^2}{cd} \times \frac{d^2}{15c}$

Worked example

Problem: Simplify $\frac{3a^3}{ac} \times \frac{6bc}{ab^2}$

Solution:

$$\begin{aligned} & \frac{3a^2}{c} \times \frac{6c}{ab} \\ &= \frac{3a}{1} \times \frac{6}{b} \\ &= \frac{18a}{b} \end{aligned}$$

Exercise Practise multiplying fractions

52 Where possible, simplify the following algebraic fractions and list the excluded values of the variables:

(a) $\frac{2x^3}{x} \times \frac{x}{2x^2}$

(b) $\frac{-x}{x^2} \times \frac{2y^3}{y}$

(c) $\frac{-2x^5}{6x^3} \times \frac{3x^2}{-4}$

(d) $\frac{4n^2}{m^7} \times \frac{m^5}{-2n^3}$

(e) $\frac{a^2b^2}{-3} \times \frac{b}{b^3}$

(f) $\frac{2m^7}{m^2n^3} \times \frac{n^2}{4}$

(g) $\frac{6}{x^3y^2} \times \frac{-2x^2y^5}{y^2}$

(h) $\frac{5a^3b^2}{7} \times \frac{2a^2b^2}{-10b^5}$

(i) $\frac{m^2n^2}{n^2} \times \frac{8}{4m^2n^3}$

(j) $\frac{13x^5y^7}{y^2} \times \frac{x^3y^2}{2x^2y^2}$

(k) $\frac{a^2b^2}{2a^5b^5} \times \frac{7a^3b^7}{b^2}$

(l) $\frac{16m^2n^3}{2m^5n^7} \times \frac{3m^7n^2}{4m^4n^2}$

Multiplying algebraic fractions requiring factorisation

Using the property $\frac{a}{b} \times \frac{x}{y} = \frac{ax}{by}$ if $b \neq 0$ and $y \neq 0$ to multiply algebraic fractions that require factorisation.

Exercises Revise

53 Factorise the following:

(a) $x^2 + 4x + 4 - y^2$

(b) $8x^3 + 1$

54 Simplify the following algebraic fractions:

(a) $\frac{a^2 - b^2}{a + b} \times \frac{4}{2}$

(b) $\frac{x^2 - 9}{(x - 2)^2} \times \frac{x^2 - 4x + 4}{x - 3}$

Worked example

Problem: Simplify $\frac{x^2 - x - 2}{x^2 + x - 6} \times \frac{x^2 + 3x}{x^2 + 3x + 2}$

Solution:

$$\begin{aligned} & \frac{(x+1)(x-2)}{(x+3)(x-2)} \times \frac{x(x+3)}{(x+1)(x+2)} \\ &= \frac{(x+1)}{(x+3)} \times \frac{x(x+3)}{(x+1)(x+2)} \\ &= \frac{x}{x+2} \end{aligned}$$

Exercise Practice and problems

55 Where possible, simplify the following algebraic fractions and list the excluded values of the variables:

(a) $\frac{3k - 5}{2k + 1} \times \frac{6k + 3}{6k - 10}$

(b) $\frac{10p - 14}{15p + 20} \times \frac{3p + 4}{5p - 7}$

(c) $\frac{5a + 35}{a^2 - 25} \times \frac{3a + 15}{a^2 - 49}$

(d) $\frac{5x + 15}{3x - 12} \times \frac{7x + 21}{2x - 8}$

(e) $\frac{a^3 - 5a}{-3a - 6} \times \frac{4a + 8}{a^2 - 5a}$

(f) $\frac{2a}{2a + b} \times \frac{2ab + b^2}{6a^2}$

(g) $\frac{x^2 - 5x + 6}{x} \times \frac{x + 2}{x^2 - 3x}$

(h) $\frac{x^2 - xy}{xy + y^2} \times \frac{xy - y^2}{x^2 + xy}$

(i) $\frac{x^2 - y^2}{x^2 - 2xy + y^2} \times \frac{xy - y^2}{xy + y^2}$

(j) $\frac{x^2 - 25a^2}{x^2 - 3ax - 10a^2} \times \frac{x^2 - 4a^2}{x^2 + 3ax - 10a^2}$

(k) $\frac{a^2 - 4a - 5}{a^3 - 8} \times \frac{a^2 + 2a + 4}{a^2 - 4a}$

(l) $\frac{3x^3 + 81}{x + 3} \times \frac{4}{2x^2 - 6x + 18}$

4.14 Dividing algebraic fractions

We use the multiplicative inverse to divide two algebraic fractions and we will divide algebraic fractions that do not require factorisation.

In mathematics, a multiplicative **inverse** or **reciprocal** for a number x , denoted by $\frac{1}{x}$ or x^{-1} , is a number that when multiplied by x yields the **multiplicative identity**, 1.

The multiplicative inverse of a fraction $\frac{a}{b}$ is $\frac{b}{a}$.

For the multiplicative inverse of a real number, divide 1 by the number.

For example, the reciprocal of 5 is $\frac{1}{5}$, and the reciprocal of $\frac{1}{4}$ is 1 divided by $\frac{1}{4}$, or 4.

Exercises Dividing algebraic fractions

56 Complete the calculations:

(a) $\frac{3}{5} \div \frac{3}{2}$

(b) $\frac{1}{3} \div \frac{7}{6}$

57 Now, try to simplify the following algebraic fractions:

(a) $\frac{a^2}{3} \div \frac{a}{6}$

(b) $\frac{a^2}{a} \div \frac{6}{3}$

Worked example

Problem: Simplify $\frac{3a^3}{ac} \div \frac{ab^2}{6bc}$

Solution: Division is the inverse of multiplication, $\frac{a}{b} \div \frac{x}{y} = \frac{a}{b} \times \frac{y}{x}$ if $b \neq 0$, $x \neq 0$ and $y \neq 0$.

$$= \frac{3a^3}{ac} \times \frac{6bc}{ab^2}$$

$$= \frac{3a^2}{c} \times \frac{6c}{ab} \quad \text{Use the property } \frac{ax}{a} = x \text{ if } a \neq 0 \text{ to simplify the algebraic fractions.}$$

$$\frac{3a}{1} \times \frac{6}{b} \quad \text{Use the property } \frac{A \times C}{B \times C} = \frac{A}{B} \text{ if } B \neq 0 \text{ and } C \neq 0 \text{ to simplify algebraic fractions.}$$

$$\frac{18a}{b} \quad \text{Use the property } \frac{a}{b} \times \frac{x}{y} = \frac{ax}{by} \text{ if } b \neq 0 \text{ and } y \neq 0 \text{ to multiply the fractions, provided } a, b \text{ or } c \neq 0.$$

Exercise Practise dividing algebraic fractions

58 Where possible, simplify the following algebraic fractions and list the excluded values of the variables:

(a) $\frac{2x^3}{x} \div \frac{x}{2x^2}$

(b) $\frac{-x}{x^2} \div \frac{2y^3}{y}$

(c) $\frac{-2x^5}{6x^3} \div \frac{3x^2}{-4}$

(d) $\frac{4n^2}{m^7} \div \frac{m^5}{-2n^3}$

(e) $\frac{a^2b^2}{-3} \div \frac{b}{b^3}$

(f) $\frac{2m^7}{m^2n^3} \div \frac{n^2}{4}$

$$(g) \frac{6}{x^3y^2} \div \frac{-2x^2y^5}{y^2}$$

$$(h) \frac{5a^3b^2}{7} \div \frac{2a^2b^2}{-10b^5}$$

$$(i) \frac{m^2n^2}{n^2} \div \frac{8}{4m^2n^3}$$

$$(j) \frac{12x^5y^7}{y^2} \div \frac{x^3y^2}{2x^2y^2}$$

$$(k) \frac{a^2b^2}{2a^5b^5} \div \frac{7a^3b^7}{b^2}$$

$$(l) \frac{16m^2n^3}{2m^5n^7} \div \frac{3m^7n^2}{4m^4n^2}$$

Use the multiplicative inverse to divide algebraic fractions and divide algebraic fractions that require factorisation.

Exercise Dividing using factorisation

59 Factorise the following:

$$(a) x^2 - 4x + 4$$

$$(b) x^2 - 9$$

$$(c) a^2 - b^2$$

Now simplify the following algebraic fractions:

$$(d) \frac{a^2 - b^2}{a + b} \times \frac{4}{2}$$

$$(e) \frac{x^2 - 9}{(x - 2)^2} \times \frac{x^2 - 4x + 4}{x - 3}$$

Worked example

Problem: Simplify $\frac{x^2 - x - 2}{x^2 + x - 6} \div \frac{x^2 + 3x + 2}{x^2 + 3x}$

Solution:

$$\begin{aligned} & \frac{x^2 - x - 2}{x^2 + x - 6} \div \frac{x^2 + 3x + 2}{x^2 + 3x} \\ &= \frac{x^2 - x - 2}{x^2 + x - 6} \times \frac{x^2 + 3x}{x^2 + 3x + 2} \\ &= \frac{(x + 1)(x - 2)}{(x + 3)(x - 2)} \times \frac{x(x + 3)}{(x + 1)(x + 2)} \\ &= \frac{1}{1} \times \frac{x}{x + 2} \\ &= \frac{x}{x + 2} \end{aligned}$$

Exercise Practise dividing by using factorisation

60 Where possible, simplify the following algebraic fractions and list the excluded values of the variables:

$$(a) \frac{6k - 10}{2k + 1} \div \frac{3k - 5}{2k + 1}$$

$$(b) \frac{10p - 14}{5p - 7} \div \frac{15p + 20}{3p + 4}$$

$$(c) \frac{5a + 35}{a^2 - 25} \div \frac{a - 1}{a - 5}$$

$$(d) \frac{5x + 15}{3x - 12} \div \frac{3 - x}{x - 4}$$

$$(e) \frac{a^3 - 5a^2}{-3a - 6} \times \frac{-3}{a^2} \div \frac{a^2 - 5a}{a^3 - 5a^2}$$

$$(f) \frac{3a}{2a + b} \times \frac{2ab + b^2}{b} \div \frac{6a^2}{2a}$$

$$(g) \frac{x^2 - 5a^2}{3a^2} \div \frac{x}{x+2} \times \frac{a^2}{x^2 - 3x}$$

$$(h) \frac{7}{xy + y^2} \div \frac{x^2 - xy}{xy - y^2} \times \frac{4}{x^2 + xy}$$

$$(i) \frac{x^2 - 2xy + y^2}{xy - y^2} \div \frac{x^2 - y^2}{y} \times \frac{-x}{xy + y^2}$$

$$(j) \frac{x^2 + 3ax - 10a^2}{x^2 - 4a^2} \div \frac{x^2 - 25a^2}{x^2 - 3ax - 10a^2} \times \frac{x - a}{3x - 3a}$$

$$(k) \frac{a^2 - 4a - 5}{a^3 - 8} \times \frac{a^2 - 9}{a + 3} \div \frac{a^2 - 4a}{a^2 + 2a + 4}$$

$$(l) \frac{3x^3 + 81}{x + 3} \times \frac{6}{x^2 - 6x + 18} \div \frac{x - 3}{2x}$$

If A , B , X and Y are polynomials:

$$\frac{A}{B} \times \frac{X}{Y} = \frac{AX}{BY} \text{ if } B \neq 0 \text{ and } Y \neq 0$$

$$\frac{A}{B} \div \frac{X}{Y} = \frac{A}{B} \times \frac{Y}{X} = \frac{AY}{BX}$$

if $B \neq 0$, $X \neq 0$ and $Y \neq 0$

$$\frac{A \times C}{B \times C} = \frac{A}{B} \text{ if } B \neq 0 \text{ and } C \neq 0$$

$$\frac{AX}{A} = X \text{ if } A \neq 0$$

4.15 Summary

- **Mathematical notation** is a writing system that we use for recording concepts in mathematics. This notation uses symbols or symbolic expressions, intended to have precise meaning.
- We refer to algebraic concepts as follows: The known value is called the **constant**, the unknown value is called the **variable**, and the action we take with these values is called the **operation**.
- The process of completing the expression by assigning a value to the variable is referred to as **evaluating the expression**.
- Algebraic expressions that have the same numerical value for the same value of x , but look different, are equivalent expressions.
- The parts that are added are called the **terms of the expression**: If addition and/or subtraction is the last step in evaluating an algebraic expression, the expression is called a **sum expression**.
- The parts that are multiplied are called the **factors of the expression**: If multiplication is the last step in evaluating an algebraic expression, then the expression is called a **product expression**. If division is the last step in evaluating an algebraic expression, then the expression is called a **quotient expression**.
- Expressions with more than one term are called **polynomials**. One term is a **monomial**, two terms is a **binomial**, and three terms is a **trinomial**.
- We manipulate expressions by adding and subtracting **like terms** to simplify expressions. Like terms are terms that have the same letter symbols, having the same exponent.

- We use the **commutative property** of numbers to group like terms together. We use the **associative property** of numbers to add or subtract like terms. We use the **distributive property** of numbers to multiply or expand polynomials.
- Multiplication is repeated addition and exponents are repeated multiplication.
- The process of writing a sum expression (polynomial) as a product is called **factorisation**. This is the inverse of expansion. Each part of a product is called a **factor of the expression**. Factorisation means that a polynomial is written as an equivalent monomial.
- **Coefficient** is a number or symbol multiplied with a variable or unknown quantity in an algebraic term.
- $a^2 - b^2$ is called the difference between two squares $(a - b)(a + b)$
- $a^3 + b^3 = (a + b)(a^2 - ab + b^2)$ and $a^3 - b^3 = (a - b)(a^2 + ab + b^2)$ is called the sum and difference of cubes.
- An **algebraic fraction** is a fraction with variable in its numerator and denominator.

4.16 Consolidation exercises

1 Represent the following:

- (i) on a number line
- (ii) in interval notation
- (iii) in set builder notation.

- | | | |
|---------------------|---------------------|-------------------|
| (a) $-5 < x \leq 2$ | (b) $0 \geq x > -4$ | (c) $-1 > x > -6$ |
| (d) $2 < x < 8$ | (e) $m \neq 3$ | (f) $k > 1$ |

2 Calculate the values of the following where $x = 3$:

- | | | |
|----------------------|----------------------|------------------|
| (a) $(x + 3)(x - 2)$ | (b) $2x + 5$ | (c) $2x(4x - 1)$ |
| (d) $x^2 - 5x - 6$ | (e) $(x + 5)(x - 6)$ | (f) $(x + 6)^2$ |

3 Simplify the following:

- | | | |
|-----------------------------|------------------------------|-------------------------------------|
| (a) $\frac{ab}{b}$ | (b) $\frac{a}{ab}$ | (c) $\frac{15y}{3}$ |
| (d) $\frac{x^2 - 1}{x - 1}$ | (e) $\frac{24q + 6}{4q + 1}$ | (f) $\frac{3(x + y)^2}{9(x + y)^3}$ |
| (g) $\frac{12ab}{24a^2b}$ | (h) $\frac{x^6}{(x + y)^2}$ | |

4 If $x = 2$, $y = -1$ and $z = -3$, what will the value of the following be?

- | | |
|--------------------------|--|
| (a) $\frac{x^3y^4}{z^2}$ | (b) $\frac{-3x^4y^2z^3 + 6x^2yz^2}{9xyz - 3x^2y^2z}$ |
|--------------------------|--|

5 Simplify the following algebraic fractions:

(a) $\frac{3y-y}{y}$

(b) $\frac{3y+y^2}{y}$

(c) $\frac{a+a}{2}$

(d) $\frac{b-b}{b}$

(e) $\frac{5z-2z}{5z^3}$

(f) $\frac{x-3}{3}$

6 Simplify:

(a) $\frac{5x-15}{5}$

(b) $\frac{2y^2+6xy}{2y(y+3x)}$

(c) $\frac{a(a-5)-2a(a-5)}{1-a}$

(d) $\frac{b^2-4b+4}{(x-2)^2}$

(e) $\frac{1-x-y}{1-(x+y)^2}$

(f) $\frac{(p-q)^2-8q^2}{4p^2-16pq}$

7 (a) What will the breadth of a rectangle be if the area is q^2-4q+4 and the length is $(q-2)^2$?

(b) What will the breadth of the rectangle be if $q=4$?

8 Simplify the following:

(a) $\frac{4a^2}{12a} \times \frac{3}{a}$

(b) $\frac{27b^3}{-9b} \times \frac{4b^2}{-16b}$

(c) $\frac{x^5}{5y^3} \times \frac{15y^4}{2x^3}$

(d) $\frac{3a^3b^2}{c^5} \times \frac{c^3}{9ab}$

(e) $\frac{a}{b^2} \times c$

(f) $\frac{a^2}{b} \div c^3$

(g) $\frac{2x^3y^2}{6x} \div \frac{3xy}{x^2y}$

(h) $\frac{4pq^3}{2} \div \frac{5p^3q^4}{15p}$

(i) $\frac{ab}{c} \div \frac{a^3}{bc^2} \div abc$

(j) $\frac{3x^2y}{6y^3} \times \frac{4y^6z^5}{2z} \div \frac{2z^3}{x^4y^2}$

9 Simplify the following:

(a) $\frac{a^2+a-12}{4a^2-16a} \div \frac{a^3+4a^2}{a^2-16} \times \frac{1}{a+4}$

(b) $\frac{3x-2y}{x-2y} \div \frac{6x+2y}{x-2y} \div \frac{2x-3y}{3x-y}$

(c) $\frac{2x^2-4x-6}{3x^2} \div \frac{x^2-x-6}{3(x-1)^2}$

(d) $\frac{x^3+y^3}{2x^3-x^2y-3xy^2} \div \frac{x^3y-x^2y^2+xy^3}{4x^4-9x^2y^2}$

10 Simplify:

(a) $\frac{2}{x} + \frac{3y-2}{xy}$

(b) $1 + \frac{a-3}{4}$

(c) $\frac{1}{3a} - \frac{3}{6a} + \frac{5}{9a}$

(d) $\frac{4x}{x^2-9} - \frac{2}{x+3} - \frac{1}{3-x}$

(e) $5 + \frac{p}{q}$

(f) $\frac{y+1}{y} - \frac{y+3}{4y}$

11 Factorise the following expressions:

(a) x^2-16

(b) $x^2-8x+12$

(c) x^2-x-6

(d) p^2+2p-3

(e) x^2-25

(f) $y^2-24p+144$

(g) $ac+bc+bd+ad$

(h) $m(x-y)+3(y-x)$

(i) $(x-1)-a(1-x)$

(j) $3x-2ym-mx+6y$

(k) $x^2y-x^2-xy^2+xy$

(l) $1-3x-3xy-y^2$

5 EQUATIONS AND INEQUALITIES

In this chapter, you will:

- revise solving linear equations and quadratic equations by factorisation
- solve simultaneous linear equations with two variables
- revise notation (interval, set builder, number line, sets)
- solve simple linear inequalities (and show solutions graphically)
- manipulate formulae (technical related) and solve word problems involving linear, quadratic, or simultaneous linear equations

5.1 Getting ready to learn

Working with number relationships

When we work with variables, we need to remember our ways of working with numbers. We use exactly the same rules for variables.

Worked example

In each of the examples below, the number sentences have been rearranged. Read through these examples carefully and discuss:

A. What have we done to each equation to change the way it is written?

B. Do the equations stay true in each case?

$$8 + 5 = 13$$

$$8 = 13 - 5$$

$$5 = 13 - 8$$

$$6 \times 4 = 24$$

$$6 = \frac{24}{4}$$

$$4 = \frac{24}{6}$$

$$9 \times 3 + 7 = 34$$

$$9 \times 3 = 34 - 7$$

$$9 = \frac{34 - 7}{3}$$

$$3 = \frac{34 - 7}{9}$$

5.2 Working with equations

An equation in x means an equation that contains the variable x . This is an invitation to calculate all possible values of x so that two given expressions in x on either side of the equals sign are equal. Any number that we substitute for x that makes the equality true is called a **solution**.

Linear equations in one variable

To solve an equation in one variable, we pretend to know what the solution is. Then we arrange the equation to calculate what the variable is.

Here is an example using letters a , b , and c for the known numbers:

$$x + b = c$$

$$x = c - b$$

$$ax + b = c$$

$$ax = c - b$$

$$x = \frac{c - b}{a}$$

$$ax = b$$

$$x = \frac{b}{a}$$

Worked examples

Solve for x . Check your answer in each case.

A. Problem: $x + 4 = 7$

Solution: $x = 7 - 4$

$$x = 3$$

Check: $3 + 4 = 7$

B. Problem: $2x = 5$

Solution: $x = \frac{5}{2}$

$$x = 2\frac{1}{2}$$

Check: $2\left(\frac{5}{2}\right) = 5$

C. Problem: $2x + 5 = 11$

Solution: $2x = 11 - 5$

$$x = \frac{11 - 5}{2}$$

$$x = \frac{6}{2}$$

$$x = 3$$

Check: $2 \times 3 + 5 = 6 + 5 = 11$

Exercises

1 Solve for x and check your answer in each case.

(a) $x + 2 = 0$

(b) $x + 2 = -4$

(c) $2x = 0$

(d) $2x = -4$

(e) $\frac{1}{3}x = 9$

(f) $x - 2 = -4$

2 Solve for x in each of the following:

(a) $4x + 1 = 9$

(b) $4x + 1 = -7$

(c) $4x + 1 = 2$

(d) $4x + 1 = 0$

(e) $4x + 1 = -2$

(f) $4x + 1 = 4$

(g) $4x + 1 = 1$

(h) $4x + 1 = -11$

More equations

Linear equations of the form $Ax + B = Cx + D$; (A , B , C , and D are constants, and $C \neq A$.)

We assume that x is a number, so that $Ax + B = Cx + D$, then:

$$Ax - Cx = D - B$$

$$(A - C)x = D - B$$

$$x = \frac{D - B}{A - C}$$

Worked examples

A. Problem: Solve for x : $3x + 4 = 2x + 1$

Solution: $3x + 4 = 2x + 1$

$$3x - 2x = 1 - 4$$

$$(3 - 2)x = 1 - 4$$

$$x = \frac{1 - 4}{3 - 2}$$

$$x = \frac{-3}{1} = -3 \quad \text{Check: } 3(-3) + 4 = -9 + 4 = -5, \text{ and } 2(-3) + 1 = -6 + 1 = -5$$

So $x = -3$ is the solution of $3x + 4 = 2x + 1$

B. Problem: Solve for x : $\frac{x}{5} + 1 = 2x - 8$

Solution: $\frac{x}{5} + 1 = 2x - 8$

$$\frac{x}{5} - 2x = -8 - 1$$

$$\left(\frac{1}{5} - 2\right)x = -8 - 1$$

$$x = \frac{-8 - 1}{\frac{1}{5} - 2}$$

$$x = \frac{-9}{\frac{-9}{5}}$$

$$x = 5 \quad \text{Check: } x = \frac{5}{5} + 1 = 2, \text{ and } 2(5) - 2 = 10 - 2 = 8$$

So $x = 5$ is the solution to $\frac{x}{5} + 1 = 2x - 8$

Exercise

3 Solve for x in each of the following:

(a) $5x = 3x + 2$

(b) $5x - 1 = 3x + 13$

(c) $-7x + 8 = 2 - 13x$

(d) $x + 3 = 2x - 4$

(e) $\frac{x}{3} + 4 = 2x - 1$

(f) $\frac{x}{3} - 7 = 9 - x$

(g) $\frac{x}{2} + 10 = 85 - 7x$

(h) $5 + \frac{x}{4} = -2x + \frac{1}{2}$

Solving equations with fractions

Sometimes, a linear expression disguises itself as a rational expression such as $\frac{x-3}{3x+1} = 2$. In cases such as this one, we need to ensure that we are not dividing by 0, by considering only those values for which the denominator is not 0. In other words, we need to put a restriction on the denominator, such that it is not equal to 0.

Worked example

Problem: Solve for x in $\frac{x-3}{3x+1} = 2$, where $x \in \mathbb{Q}$.

Solution: $\frac{x-3}{3x+1} = 2$, restriction for the equation to be true $3x+1 \neq 0$, $\therefore x \neq -\frac{1}{3}$

$$x - 3 = 2(3x + 1)$$

$$x - 3 = 6x + 2$$

$$-5x = 5$$

$$x = -1$$

$$\text{Check: } \frac{-1-3}{3(-1)+1} = \frac{-4}{-2} = 2$$

Also: $-1 \neq -\frac{1}{3}$ (restriction)

$\therefore x = -1$ is the solution to $\frac{x-3}{3x+1} = 2$

Exercise

4 Solve for x , where $x \in \mathbb{Q}$ (state the restriction on the denominator).

(a) $\frac{x+1}{2} = 6$

(b) $\frac{2}{x+1} = 6$

(c) $\frac{3x+1}{x} = 2$

(d) $\frac{5x-2}{6x+3} = 3$

(e) $\frac{9x-3}{x-1} = 3$

(f) $\frac{x-1}{x+1} = -2$

5.3 Simultaneous equations

Linear equations in two variables

We say that a pair of linear equations, such as $2x + y = 5$ and $3x + 2y = 4$, is a system of linear equations or simultaneous equations in x and y .

To solve simultaneous equations, we need to find all the ordered pairs of numbers that are solutions of both equations. Such an ordered pair is called the solution of the system.

Worked example

Problem: Let us consider the equation $2x + y = 5$. Which pair(s) of numbers x and y make the equation true?

There are many pairs such as $(3; -1)$; $(0; 5)$; $(2; 1)$; $(\frac{5}{2}; 0)$; $(6; -7)$; $(\frac{3}{2}; 2)$. Let us now consider for the equation $3x + 2y = 4$, which pair(s) of numbers x and y , make the equation true? Again, there are many such pairs; some of them are given below:

$$(1; \frac{1}{2}); (0; 2); (\frac{1}{3}; \frac{3}{2}); (6; -7); (-2; 5); (4; -4)$$

From the two sets of ordered pairs of numbers, $(6; -7)$ is common to both equations. So we say $(6; -7)$ is a solution common to both equations.

A. Solve x and y simultaneously:

Solve for x and y : $2x + y = 5$ and

$$3x + 2y = 4$$

Label the first equation (1) and the second equation (2):

$$2x + y = 5 \dots\dots\dots(1)$$

$$3x + 2y = 4 \dots\dots\dots(2)$$

Write equation (1) in terms of y :

$$y = 5 - 2x \dots\dots\dots(3)$$

We can now substitute this expression for y into equation (2):

$$3x + 2(5 - 2x) = 4$$

$$3x + 10 - 4x = 4$$

$$3x - 4x = 4 - 10$$

$$-x = -6$$

$$x = 6$$

To calculate the value of y , substitute the solution above, $x = 6$, into (3):

$$y = 5 - 2(6)$$

$$y = -7$$

The solution is $(6; -7)$.

B. Solve for x and y simultaneously:

Solve for x and y : $2x + y = 5$ and
 $3x + 2y = 4$

Label the first equation 1, and the second equation 2:

$$2x + y = 5 \dots\dots\dots(1)$$

$$3x + 2y = 4 \dots\dots\dots(2)$$

We are now going to multiply equation (1) by -2 because this will ensure that the magnitude of the coefficient of y in equation (1) is the additive inverse of the coefficient of y in equation (2).

Equation (1) becomes:

$$-4x - 2y = -10 \dots\dots\dots(3)$$

If we now add equation (2) and (3), the terms involving y disappear:

$$\begin{array}{r} 3x + 2y = 4 \\ -4x - 2y = -10 \\ \hline -x \quad = -6 \\ \therefore x = 6 \end{array}$$

We use the solution, $x = 6$, and substitute this into equation (2) in order to calculate the value of y :

$$\begin{array}{r} 3x + 2y = 4 \\ 3(6) + 2y = 4 \\ 18 + 2y = 4 \\ 2y = 4 - 18 \\ 2y = -14 \\ y = \frac{-14}{2} \\ y = -7 \end{array} \quad \text{The solution is } (6; -7)$$

The **additive inverse** of a number a is the number that, when added to a , equals zero, e.g. $2 + (-2)$, and $-2y + 2y$.

Exercise

5 Solve the following simultaneous equations:

(a) $5x + 3y = 8$ and $9x - y = 9$

(b) $6x + 11y = 1$ and $5x - y = 1$

(c) $x + 4y = 11$ and $2x + 3y = 7$

(d) $-3x + 2y = 1$ and $7x - 6y = -1$

(e) $\frac{1}{2}x + 3y = 8$ and $5x + 6y = 18$

(f) $-x + 10y = 5$ and $-6x - y = 30$

(g) $0,8x + 1,2y = 14$ and $0,1x - 0,6y = 7$

(h) $\frac{2}{5}x - \frac{y}{3} = 3$ and $5x - 3y = 16$

5.4 Linear inequalities

We come across expressions of inequality more often than we may think. On television, for example, before a programme is shown there is something said about the age restriction of who can or cannot watch the programme. As an introduction to this section, think about the situation given below:

- (a) If the age restriction for watching a certain programme on television is shown as 13 years, can you list all the possible ages of people who can watch the programme?
- (b) Amantha plays soccer for the under 17 national ladies soccer team. How old is Amantha?

Exercises Revision

6 Consider the expression $2x + 1$. List 10 possible values of x :

- (a) if $x \in \mathbb{R}$
- (b) if $x \in \mathbb{Z}$
- (c) if $x \in \mathbb{N}$
- (d) if $x \in \mathbb{N}_0$
- (e) if $x \in \mathbb{Q}$

7 (a) Can the set of numbers below be part of the set of real numbers (\mathbb{R})? Give an explanation for your answer.

$$\left\{-6; -3,6; -2\frac{1}{5}; 0; 3; 5,18; 10\frac{3}{5}\right\}$$

(b) Can the set of numbers below be part of the set of integers (\mathbb{Z})? Give an explanation for your answer.

$$\{-6; -5; -4; -3; -2; -1; 0; 1; 2; 3; 4; 58; 600\}$$

(c) Can the set of numbers below be part of the set of natural numbers (\mathbb{N})? Give an explanation for your answer.

$$\{-20; -10; 0; 1; 2; 60; 416\}$$

(d) Can the set of numbers below be part of the set of whole numbers (\mathbb{N}_0)? Give an explanation for your answer.

$$\{0; 100; 200; 300; 600\}$$

(e) Can the set of numbers below be part of the set of rational numbers (\mathbb{Q})? Give an explanation for your answer.

$$\left\{-152; \frac{-13}{200}; 0; \sqrt[3]{125}; 100\right\}$$

To answer exercises 8 to 10, you will have to refer to the table shown below.

x	-3	-2	-1	0	1	2	3
$2x + 1$	-5	-3	-1	1	3	5	7

- 8 The table above shows some information about the expression $2x + 1$, where x is a real number. Refer to the table to answer the questions below.
- (a) For which value(s) of x is $2x + 1 = 1$?
- (b) For which value(s) of x is $2x + 1 = -5$?
- (c) For which value(s) of x is $2x + 1 = 3$?
- 9 (a) For which value(s) of x is $2x + 1$ greater than -1 ? $2x + 1 > -1$
- (b) For which value(s) of x is $2x + 1$ greater than 1 ? $2x + 1 > 1$
- (c) For which value(s) of x is $2x + 1$ greater than -5 ? $2x + 1 > -5$
- (d) For which value(s) of x is $2x + 1$ less than -1 ? $2x + 1 < -1$
- (e) For which value(s) of x is $2x + 1$ less than 1 ?
- (f) For which value(s) of x is $2x + 1$ less than -3 ?
- 10 (a) For which value(s) of x is $2x + 1 = 0$?
- (b) For which value(s) of x is $2x + 1$ greater than 0 ?
- 11 (a) Does the table show all the values for which $2x + 1$ is greater than 1 ?
Try $x = 10$ or $x = 807$.
- (b) Does the table show all the values for which $2x + 1$ is less than 1 ?
Try $x = -10$, or $x = -501$.

Listing possible values

List all the realistic values of k that satisfy the inequality $0 < k \leq 2$, k is an integer.

The sign \leq means that k can be less than 2 or equal to 2 .

The sign $<$ means k can be greater than 0 .

So, there are only two such integers: $\{1; 2\}$

Exercise

12 Write down all the integers that satisfy each of the following inequalities:

(a) $4 < k < 9$

(b) $-1 < k < 1$

(c) $-5 < k < 2$

(d) $-5 < k \leq 2$

(e) $-5 \leq k < 2$

(f) $-5 \leq k \leq 2$

$>$ means 'greater than'
 $<$ means 'less than'
 \geq means 'greater than or equal to'
 \leq means 'less than or equal to'

Set-builder notation

Sometimes it is not realistic to list all the possible values in a solution set, for example, if there are an infinite number of solutions.

The best thing we can do is to say how we can build the list. We use set builder notation to do this.

Worked examples

A. Problem: $\{x \in \mathbb{Z} \mid x < 0\}$ means the set of all integer numbers such that x is less than 0.

Solution: This can be written as $\{x \in \mathbb{Z} \mid x < 0\} = \{-1, -2, -3, \dots\}$

We can show this using the number line:

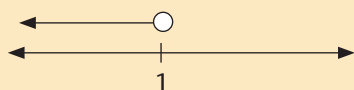

Using the interval notation: $(-\infty; 1)$

B. Problem: $\{x \in \mathbb{Z} \mid x \geq 1\}$ means all real numbers such that x is greater than or equal to 1.

Solution: This can be written as $\{x \in \mathbb{Z} \mid x \geq 1\} = \{1; 1\frac{1}{2}; 2; \dots\}$

We can show this in other ways, for example:

(a) Using the number line:

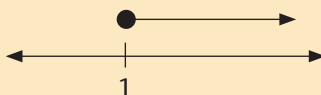

(b) Using the interval notation: $[1; \infty)$

C. Problem: Express the set of numbers shown on the number line below in:

(a) set builder notation

(b) interval notation

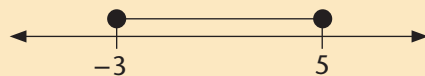

Solution:

(a) $\{x \in \mathbb{R} \mid -3 \leq x \leq 5\}$

(b) $[-3; 5]$

Exercises

13 $S = \{-1, 0, 1, 2, 3, \dots\}$ S is a set of integers.

- Express S in a set builder notation.
- Express S using the interval notation.
- Express S using the number line.

14 Copy and complete the following table. An example has been done for you.

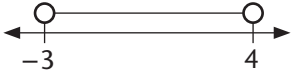
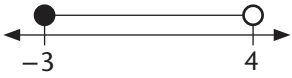
Words	Interval Notation	Set Builder Notation	Number Line
A. Set of real numbers between -3 and 4	$(-3; 4)$	$\{x \mid -3 < x < 4; x \in \mathbb{R}\}$	
	$(-3; 4]$		
		$\{x \mid -3 \leq x \leq 4; x \in \mathbb{R}\}$	
			

15 If you consider the statement: 'All real numbers from zero up to and including 10,' which statement(s) below represent the situation best?

- $0 \leq x < 10$
- $(0; 10]$
- $0 < x < 10$
- $[x \in \mathbb{Z} \mid 0 < x \leq 10]$

16 How do you read the statement $[x \in \mathbb{R} \mid 2 \leq x \leq 7]$?

- the numbers 3, 4, 5, 6?
- a number between 2 and 7?
- a real number between 2 and 7, including both 2 and 7?
- a number greater than 2 but less than 7?

- 17 What is the difference between:
- (a) $(2; 7)$ and $[2; 7]$? (b) $(2; 7)$ and $\{2; 7\}$ (c) $[2; 7)$ and $(2; 7]$
- 18 Express each of the above in question 17 (a) – (c) using:
- (a) a set builder notation (b) the number line
- 19 What values of x would each inequality below represent? Explain in words and also show it on a number line.
- (a) $5 < x < 8$ (b) $x < 5$ or $x > 8$
- 20 (a) If the inequalities $x \geq 2$ and $x \leq 2$ are both true, describe the possible values for x .
- (b) Show on a number line the possible values of x for this situation. Justify your answer.

5.5 Solving linear inequalities

To solve an inequality is to calculate all the possible values of x that make one expression in x bigger than, smaller than, or equal to the other.

Worked examples

Solving an equation

Problem:

Solve for x , $x \in \mathbb{R}$

Solution:

$$5x - 4 = 3x + 2$$

$$5x - 3x = 2 + 4$$

$$2x = 6$$

$$x = 3$$

Check: $5 \times 3 - 4 = 11$ and $3 \times 3 + 2 = 11$
 $\therefore x = 3$ is a solution of $5x - 4 = 3x + 2$

Solving an inequality

Problem:

Solve the inequality: $5x - 4 > 3x + 2$, $x \in \mathbb{R}$

Solution:

$$5x - 4 > 3x + 2$$

$$5x - 3x > 4 + 2$$

$$2x > 6$$

$$x > 3$$

Check: with the solution being $x > 3$, let's assume that $x = 4$

$$5 \times 4 - 4 = 16$$

$$3 \times 4 + 2 = 14$$

$$16 > 14$$

$\therefore x > 3$ is a solution of $5x - 4 > 3x + 2$

Graphically:

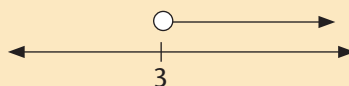

Solving an inequality

Problem: Solve the inequality: $5x - 4 \geq 3x + 2$, $x \in \mathbb{R}$

Solution: $5x - 4 \geq 3x + 2$

$$5x - 3x \geq 4 + 2$$

$$2x \geq 6$$

$$x \geq 3$$

Check: with the solution being $x \geq 3$, let's assume that $x = 4$

$$5 \times 4 - 4 = 16$$

$$3 \times 4 + 2 = 14$$

$$16 \geq 14$$

$\therefore x \geq 3$ is a solution of $5x - 4 \geq 3x + 2$

Graphically:

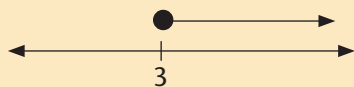

Solving an inequality is not any different from solving an equation.

Exercises

21 Solve the inequalities below where x is a real number. Also represent the solution graphically.

(a) $5x < 10$

(b) $-5x \leq 10$

(c) $5x \geq -10$

(d) $3x \leq -6$

(e) $7x > -14$

(f) $-14x < -7$

22 Solve the inequalities below where x is a real number. Also represent the solution graphically.

(a) $3x + 1 \leq 4$

(b) $2x + 1 > 5x - 2$

(c) $4x + 6 < 2x$

(d) $2x - 6 \geq 5$

(e) $x + 1 \leq -1$

(f) $-\frac{1}{2}x - 2 < \frac{1}{2}$

5.6 Solving quadratic equations by factorisation

Worked example

A. Problem: Solve the equation $x^2 - 4x + 4 = 0$

Solution: To solve the equation $x^2 - 4x + 4 = 0$, write it as a product of linear factors.

If you multiply two numbers or two expressions, the result can only equal 0 if either one of the numbers or expression is 0 or if both are 0.

$$(x - 2)(x - 2) = 0$$

$$\text{So, } x - 2 = 0 \therefore x = 2$$

We now solve the two linear equations. We must check whether we indeed have a solution by substituting the values of x into the equation.

If $x = 2$, then $x^2 - 4x + 4 = 2^2 - 4 \times 2 + 4 = 4 - 8 + 4 = 0$, $\therefore x = 2$ is the solution.

B. Problem: Solve for x if $x^2 + 3x = 0$

Solution: $x^2 + 3x = 0$

$$x(x + 3) = 0$$

$$x = 0 \text{ or } x + 3 = 0$$

$$x = 0 \text{ or } x = -3$$

Check: If $x = 0$; $x^2 + 3x = 0^2 + 3(0) = 0$

Check: If $x = -3$; $x^2 + 3x = (-3)^2 + 3(-3) = 9 - 9 = 0$

The solution is $x = 0$ or $x = -3$.

C. Problem: Solve for x if $x^2 - 121 = 0$

Solution: $x^2 - 121 = 0$

$$(x - 11)(x + 11) = 0 \quad \text{This is a difference of two squares.}$$

$$x - 11 = 0 \text{ or } x + 11 = 0$$

$$\therefore x = 11 \text{ or } x = -11$$

Check: If $x = 11$, $x^2 - 121 = 11^2 - 121 = 0$

Check: If $x = -11$, $x^2 - 121 = (-11)^2 - 121 = 0$

The solution is $x = 11$ or $x = -11$.

Exercise

23 Solve the equations below; x is a real number.

(a) $x^2 - 9x + 20 = 0$

(b) $x^2 + 6x + 8 = 0$

(c) $x^2 - 10x + 21 = 0$

(d) $x^2 + 4x - 12 = 0$

(e) $x^2 - 2x - 35 = 0$

(f) $x^2 + 6x + 5 = 0$

(g) $x^2 - 1 = 0$

(h) $x^2 - 16 = 0$

(i) $x^2 - 81 = 0$

(j) $x^2 - 25 = 0$

(k) $x^2 - 169 = 0$

(l) $x^2 - 225 = 0$

(m) $x^2 + 5x = 0$

(n) $x^2 - 5x = -14$

(o) $x^2 - x = 0$

(p) $x^2 + 3x - 4 = 0$

(q) $x^2 + 3x = 10$

(r) $-6x = -x^2 + 27$

5.7 Subject of the formula

We use formulae to relate quantities to one other. Formulae provide rules so that if we know the value of certain quantities, we can calculate the values of others.

Worked example

Problem: Make the quantity shown in brackets, the subject of the formula:

$$v = u + at \quad [u]$$

Solution: $v = u + at$

$$u + at = v$$

$$u = v - at$$

Making a quantity the subject of a formula means rearranging a formula in order to calculate a value of one of the quantities. It is the same as solving an equation.

Exercise

24 Rearrange each of the following formulae to make the quantity shown in brackets, the subject of the formula.

(a) $v = u + at$ $[t]$

(b) $v = u + at$ $[a]$

(c) $I = \frac{V}{R}$ $[V]$

(d) $I = \frac{V}{R}$ $[R]$

(e) $C = \frac{5(F - 32)}{9}$ $[F]$

(f) $A = \pi r^2$ $[r]$

(g) $A = \pi(R - r)$ $[R]$

(h) $R = \frac{PQ}{P + Q}$ $[Q]$

(i) $R = \frac{PQ}{P + Q}$ $[P]$

(j) $E = mc^2$ $[m]$

(k) $E = mc^2$ $[c]$

(l) $P = I^2R$ $[R]$

(m) $P = I^2R$ $[I]$

5.8 Word problems

When we solve word problems, it is useful to keep the following tools in mind:

- Identify the quantities involved in a given scenario. Use letter symbols for the various quantities you have identified.
- Create an equation that expresses a relationship between or amongst the quantities involved in the situation.
- Solve the equation.
- Check whether indeed you have a solution.

Worked example

Problem: The sum of two numbers is 45. One number is four times the other.

Solution: Let one of the numbers be x

The other number is $4x$.

$$x + 4x = 45$$

$$5x = 45$$

$$x = 9$$

Check: $9 + 4 \times 9 = 9 + 36 = 45$

So the numbers are 9 and 36.

Exercises

25 The rectangle and the isosceles triangle below each have the same perimeter.

Calculate the value of x .

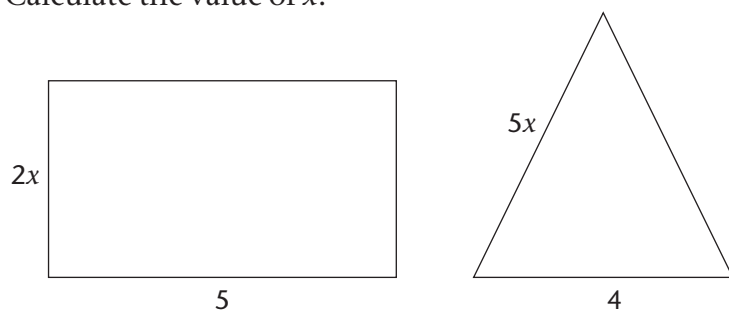

26 The sum of three consecutive odd numbers is 45. What are the numbers?

-
- 27 Two parents went to a school concert with their two children. During the interval, they met a neighbour with four of his children. It became clear during their conversation that each family had paid the same total amount for the concert tickets. If the childrens' tickets cost R10 each, how much did each adult ticket cost?
- 28 There are two numbers. Their sum is 24. One number is three times the other. What are the numbers?
- 29 At a concert a 100 tickets were sold. Adult tickets cost R150, children's tickets cost R75. A sum of R12 225 was collected. How many tickets of each kind were sold?
- 30 A test has 21 questions, with a total of 150 marks. The test consists of multiple choice questions worth 4 marks each and essay type questions worth 15 marks each. How many questions of each type are on the test?
- 31 The length of a rectangular fowl run is 3 metres more than its width. The area of the rectangle is 10 square metres. What are the dimensions of the fowl run?
- 32 The product of two consecutive integers is 42. Calculate the integers.
- 33 One batch of alloy A is made by melting 3 tonnes of refined chrome ore with 5 tonnes of refined vanadium ore.
- One batch of alloy B is made by melting 2 tonnes of refined chrome ore with 6 tonnes of refined vanadium ore.
- (a) How much of each kind of ore is needed for 5 batches of alloy A plus 3 batches of alloy B?
- (b) If 37 tonnes of chrome ore is available and 38 tonnes of Vanadium ore, how many batches of each kind of alloy can be produced?
- 34 The length of a metal rod A in cm is given by the formula $13,4 + 0,023t$ where t , is the temperature in degrees Celsius. The length of the metal rod B is given by $18,6 + 0,023t$. If the ends are 1,4 cm apart at 3°C , at what temperature will the ends touch?

5.9 Summary

- An **equation** is an equality between numbers. To solve an equation in one variable, we need to arrange the equation to calculate what the variable is.
- We solve linear equations of the form $Ax + B = Cx + D$ by making x the subject of the equation, providing that A is not equal to C .
- When solving equations involving fractions, we need to ensure that division by 0 does not take place, by considering only those values for which the denominator is not 0.
- To solve simultaneous equations, we need to find all the ordered pairs of numbers that are solutions of both equations. Such ordered pairs are called the **solution of the system**.
- Solving an inequality is to calculate all the possible values of the variable that make one expression in x bigger than, smaller than, or equal to the other.
- To solve quadratic equations, we make use of factorisation. You write it as a product of linear factors. If you multiply two numbers or two expressions, the result can only equal 0 if either one of the numbers or expression is 0, or both are 0.
- Making a quantity the **subject of the formula**, means rearranging a formula in order to calculate a value of one of the quantities.

5.10 Consolidation exercises

1 Solve for x :

(a) $11 + x = 5$

(b) $x - 3 = 10$

(c) $2x = 7$

(d) $3x = 5 + 2$

(e) $4x - 1 = 2$

(f) $\frac{1}{2}x = 9$

(g) $11x = 0$

(h) $4x + 2 = 10$

2 Solve for x :

(a) $7x = 2x + 3$

(b) $6x - 2 = 3x + 15$

(c) $-5 - 3x = 4x + 7$

(d) $x - 1 = 3x + 2$

(e) $\frac{2x}{3} + 5 = 3x - 1$

(f) $7 - \frac{x}{2} = 12 + x$

(g) $\frac{3x}{2} + 4 = \frac{x}{5} - 5$

(h) $-9 - \frac{5}{2x} = 2x - 2$

3 Solve for x , where $x \in Q$ (state the restriction on the denominator):

(a) $\frac{x+2}{3} = 6$

(b) $\frac{2}{x-1} = 4$

(c) $\frac{4x-3}{x} = 5$

(d) $\frac{3x+2}{7x-3} = 4$

(e) $\frac{3x+9}{2x-4} = 1$

(f) $\frac{x-1}{x+1} = -2$

4 Solve the following simultaneous equations:

(a) $7x - 2y = 4$ and $3x + 2y = 6$

(b) $5x + 6 = 2y$ and $x - 3y = 4$

(c) $-2x - 8 = 5y$ and $-2y + 6x = 3$

(d) $\frac{3}{4}x + 2y = 2$ and $7x - 5 = 2y$

(e) $0,9x - 3 = 1,6y$ and $0,2x + 6y = 1$

5 Write down all the integers that satisfy each inequality:

(a) $6 < k < 8$

(b) $-2 < k \leq 3$

(c) $-4 \leq k < 1$

(d) $0 \leq k \leq 5$

(e) $1 < k < 4$

(f) $-3 \leq k < 2$

- 6 $M = \{-2, -1, 0, 1, 2, \dots\}$ M is a set of integers.
- Express M in a set-builder notation.
 - Express M using the interval notation.
 - Express M using the number line.
- 7 Which statement represents all real numbers from zero up to and including 10?
- $0 \leq x < 10$
 - $(0; 10]$
 - $0 < x < 10$
 - $[x \in \mathbb{Z} \mid 0 < x \leq 10]$
- 8 Solve the inequalities below, where x is a real number, then represent the solution graphically:
- $6x < 12$
 - $-4x \leq 12$
 - $3x > 9$
 - $3x \leq -6$
 - $7x > 21$
 - $-9 \geq 6x$
 - $4x + 3 \leq 5$
 - $3x - 1 > -2x + 5$
 - $8x + 4 \leq 3x$
 - $2x + 6 \leq 5$
 - $x - 1 > 1$
 - $-\frac{1}{4}x + 2 < \frac{1}{2}$
- 9 Solve the equations below, x is a real number:
- $x^2 - 7x + 12 = 0$
 - $x^2 + 6x + 8 = 0$
 - $x^2 - 9 = 0$
 - $x^2 - 4x - 12 = 0$
 - $x^2 - 7x = 0$
 - $x^2 + 7x = 0$
 - $x^2 - x = 0$
 - $x^2 + 6x + 5 = 0$
 - $x^2 + 25 = 0$
- 10 Make the quantity shown in brackets, the subject of the formula:
- $y = u + at$ [a]
 - $v = u + ut$ [t]
 - $I = \frac{V}{R}$ [R]
 - $I = \frac{V}{R}$ [V]
 - $R = \frac{PQ}{P+Q}$ [Q]
 - $A = \pi r^2$ [r]
 - $P = I^2 R$ [I]
 - $E = mc^2$ [m]
 - $A = \pi (R - r)$ [r]

6 TRIGONOMETRY

This chapter is about a very important group of functions called **trigonometric functions**. The part of mathematics that has to do with these functions is called **trigonometry**.

- You may have applied trigonometric functions in your technical subjects. If this is so, you know *what* these functions do. However, you may be uncertain about *how* and *why* they do it. Anything you did not understand about them will become clear as you work through this chapter. It is very important to go back to those places where you used trigonometry to make sure that you *understand how* and *why* the functions worked.

In this chapter, you will learn that:

- the corresponding sides of similar right-angled triangles are in the same ratio (NB: this is generally true for *all* similar polygons)
- in right-angled triangles, trigonometric functions link input acute angles to output length ratios of the sides of the triangle
- in the Cartesian plane, trigonometric functions link input angles of all sizes to ratios, also called quotients, involving coordinates

In this chapter, you will learn:

- to determine input and output values of the trigonometric functions using diagrams, measurements, and calculations
- to use trigonometry to solve equations and to solve problems that have to do with angles, and lengths or coordinates
- to use graphs, diagrams, and algebra to represent trigonometric functions

Keep in mind that understanding trigonometry and being able to use it effectively as a tool will empower you as a technical person.

6.1 Introducing the roof pitch situation

Roof pitch

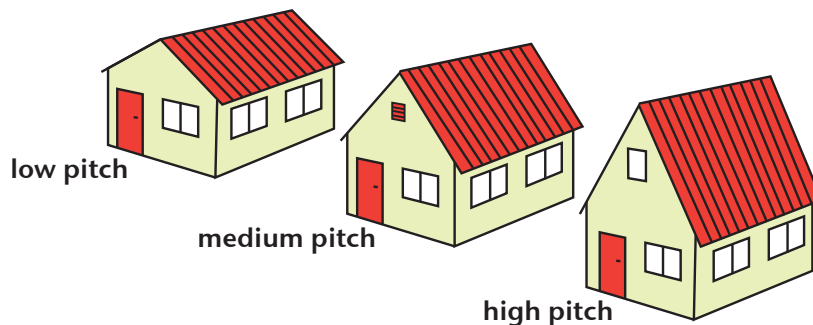

The pitch of a roof tells you how steep the roof is. Pitch can be measured in two ways as:

- an angle, measured in degrees or radians, or
- a slope, a dimensionless ratio of vertical rises to horizontal run.

An important mathematical question:

How can we change between the pitch as an angle and the pitch as a *rise: run* ratio?

We will address the question posed above as we work through the chapter. Along the way, we will learn some new math.

6.2 Revision of angles, lengths, length ratios, and similarity

Comparing angles and lengths

Example Angles and lengths

Imagine Muvhuso is standing at position O on a football field:

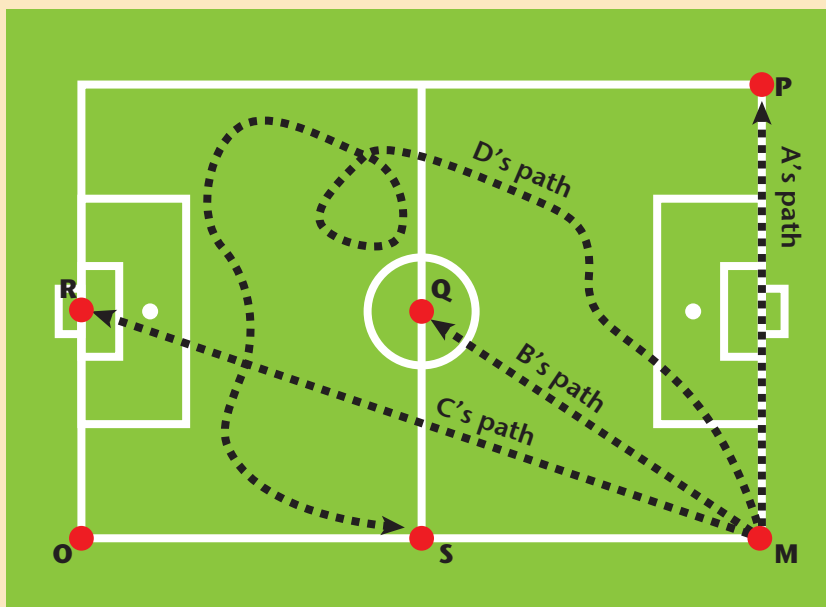

Four of her friends, A, B, C, and D, move from position M along the paths shown.

Check that you agree with the following as seen from her position at O:

- C ends up furthest from her starting position at M.
- B has covered the shortest distance, i.e. B has the smallest path length.
- A and B have moved through the same angle. The directions of their starting positions are the same and the directions of their end positions are the same as seen from her position at O.
- The change in the direction of the position of C is 90° as seen from her position at O.
- D's path is definitely the longest. But the direction of his end position as seen from her position at O, is the same as the direction of his starting position so the angle change is 0° as seen from her position at O.

Length ratios

A **ratio** is one way of comparing two values. Ratios tell us *how many times* bigger or smaller one measurement is compared to another measurement. Ratios are **dimensionless**, i.e. they have no unit.

In trigonometry, we are particularly interested in length ratios in right-angled triangles.

There is another way we can compare two measurements, by finding the **difference** between their two values. A difference tells us *how much bigger or smaller* one value is compared to another. Differences have the same unit as the two values.

Example Length ratio

Wooden beams: beam P has length a , and beam Q has length b .

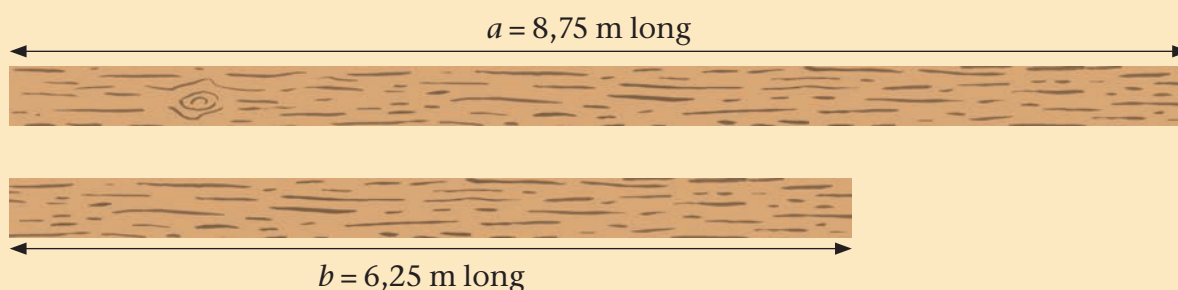

The ratio of the length of beam P to the length of beam Q can be written in these ways:

In ratio notation: $a:b = 8,75:6,25$

As a *whole number ratio*: $8,75 \div 0,25 = 35$ and $6,25 \div 0,25 = 25$, so $a:b = 35:25$

As the *simplest whole number ratio*: 5 is the highest common factor of 35 and 25 so $a:b = 7:5$. We read this as a is to b as 7 is to 5.

In rational form (quotient form): $\frac{a}{b} = \frac{8,75}{6,25} = \frac{7}{5}$

We can change the rational form into decimal form since $7 \div 5 = 1,4$ then: $\frac{a}{b} = 1,4$

Decimal form is very useful. It tells us that beam P is 1,4 times longer than beam Q. We can also write the ratio as $a:b = 1,4:1$ using the ratio notation.

We can also express the **reciprocal ratio**, the ratio of the length of beam Q to the length of beam P:

In ratio notation as $b:a = 5:7 = 1:1,4 = 0,71:1$

In rational form and in decimal form as $\frac{b}{a} = \frac{6,25}{8,75} = \frac{5}{7}$.

This tells us that the length of beam Q is the fraction 0,71 of the length of beam P.

Note: Beam P is 2,50 m longer than beam Q. This is NOT a ratio statement. This is a *difference* statement. Beam M of length 7,50 m is also 2,50 m longer than beam N of length 5,0 m. But the ratio of the lengths of beams M and N is $7,5:5 = 3:2 = 1,5:1$. So beam M is 1,5 times longer than beam N, which is not the same as for beams P and Q, where we have 1,4:1.

Right-angled triangles: the roof pitch

A very important skill you must learn in trigonometry is to see the hidden right-angled triangles in situations. Once you become good at this, things are quite straightforward.

We are beginning with the roof pitch situation, the slope or pitch of a roof.

Roofers use two ways of describing the pitch (slope) of a roof:

- The pitch angle
- The *rise: run* ratio

Are these equivalent, that is, the same in some way? Are there different ways of expressing the same thing?

Look at the following gable-end of the building in the roof pitch situation:

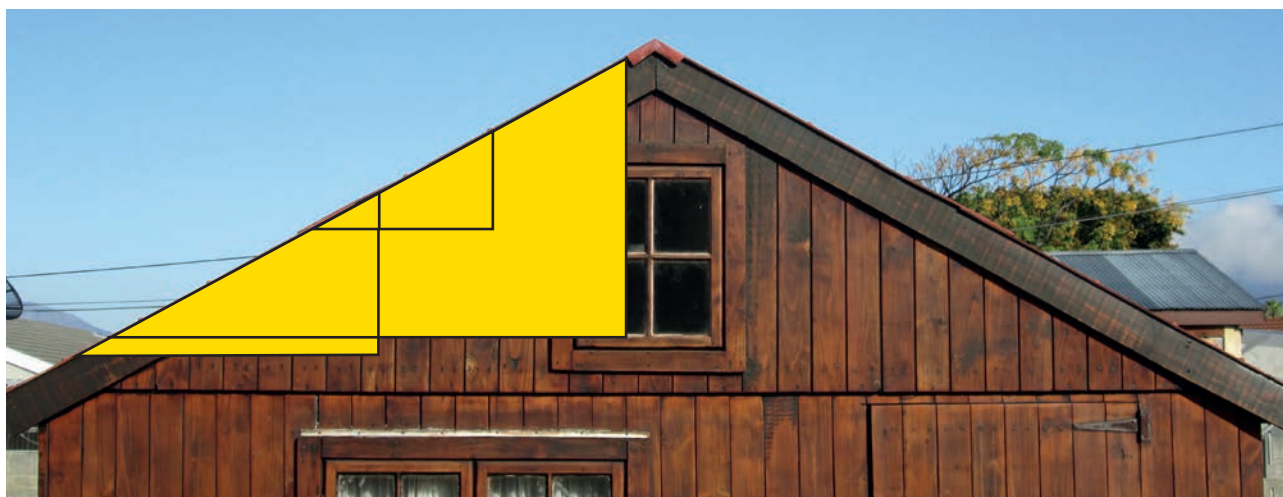

Three yellow triangles have been drawn over the picture. Their hypotenuses lie along the slope of the roof. The remaining sides are horizontal, that is, parallel with the ground, and vertical, that is, straight up from the ground.

For a roof pitch the horizontal side is called the run length, vertical side the rise length, and the hypotenuse the rafter length. We can represent these three triangles as projections of each other using a vanishing point, making sure that the corresponding sides are parallel to each other:

Note that we will use the term 'rafter length' to mean the distance between two points along the slope of the roof that corresponds to the particular rise and run we are looking at, and not just to refer to the length of the rafters themselves.

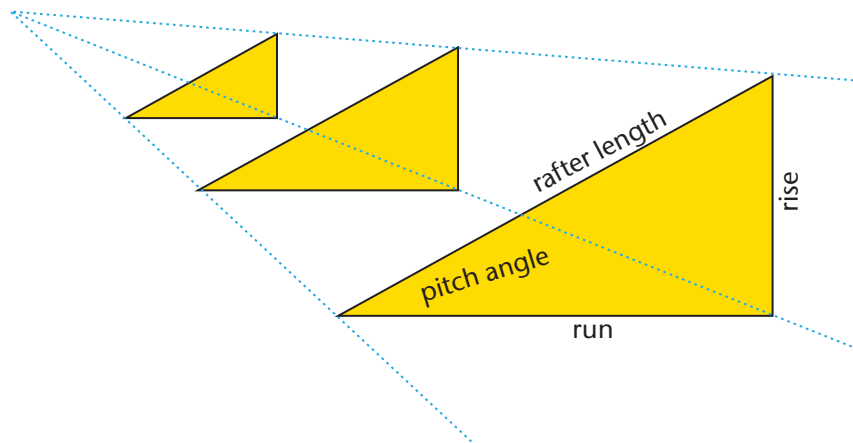

Note: The triangles are all in the plane of the page here. This is a 2-D diagram, not a 3-D diagram

The three corresponding acute angles shown are equal, and equal to the pitch angle of the roof. What can you say about the other three corresponding acute angles?

The lengths of the rises, runs, and rafter length are not the same for the three triangles.

Exercises

- 1 Use the yellow triangles on the photograph above for this exercise. Carefully measure the three pitch angles, to the nearest degree. Measure the lengths of the three sides of each of the three triangles to the nearest millimetre. What can be said about the:
 - (a) pitch angle for the triangles?
 - (b) lengths of the 'run', the 'rise', and the 'rafter length' of the triangles?
 - (c) ratio of rise to run, rise to rafter length, and run to rafter length in each triangle in ratio form, and rational form?
- 2 Construct your own set of similar right-angled triangles. Draw at least three. Measure all the angles and sides, and determine the three ratios mentioned in (c) for each triangle. Do you get what you expect?

Here is another way to represent the same three similar triangles:

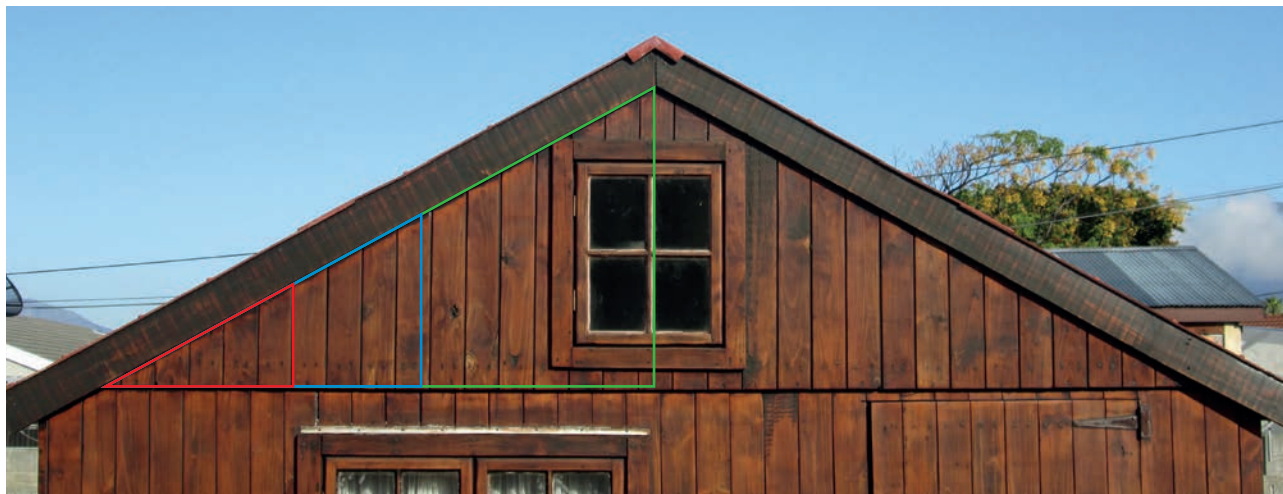

Check that you agree with the following statements:

- The green and blue triangles are projections of the red triangle through the vanishing point, located at the pitch angle vertex.
- It is clear that the triangles have the same pitch angle.
- The 'rafter lengths' are the hypotenuses that lie along the same line parallel to the slope of the roof.
- The 'runs' are on the same horizontal line, the bottom edge of the gable planks.
- The 'rises' are all vertical and parallel to each other, the long sides of the gable planks.

Something important and useful about ratios: Ratios act as multipliers. If we say that the pitch ratio is $\frac{\text{rise}}{\text{run}} = 0,67$ we mean that the rise is 0,67 of the run. So, if we 'run' horizontally by 10 cm, the roof will 'rise' vertically through 6,7 cm. If the run is 25 cm the rise will be $0,67 \times 25 \text{ cm} = 16,75 \text{ cm}$. And so on. We say that the ratio is a multiplier, or multiplying factor, or a scale factor, because we multiply the run by it to get the rise.

Make sure you can answer the following questions with confidence before you continue:

- Someone draws in a fourth, different right-angled triangle with the same pitch angle as the roof in the picture. Is this right-angled triangle similar to the three right-angled triangles in the picture?
- Are the length ratios of corresponding sides for all possible right-angled triangles that have the same pitch angle, the same?
- Someone draws two similar right-angled triangles. Will the two pairs of corresponding non-right-angles in the two triangles be equal?

Exercise Measuring pitches

- 3 The following diagrams represent cross-sections of buildings with pitched roofs. Before continuing, arrange the pitches in order of increasing size.

Now, make the necessary measurements directly on the diagrams and then express the pitch of the roof:

- as an angle
- as a ratio of *rise:run* with run = 10 units of length
- as a decimal number

Note: When we speak of corresponding angles and lengths we mean angles or lengths that are in the same corresponding positions in two different triangles. If the two triangles are similar then the two longest sides are in the same corresponding positions, the two middle sized angles, the two largest angles, the two shortest sides etc. See the sections on congruence and similarity in Chapter 8.

(a)

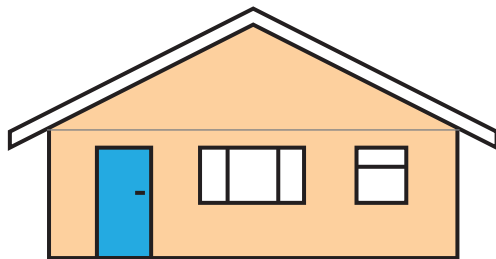

(b)



(c)

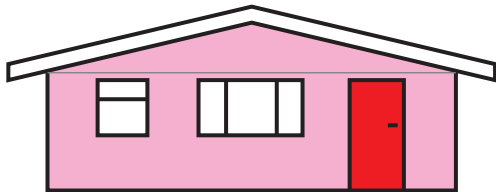

(d)



(e)

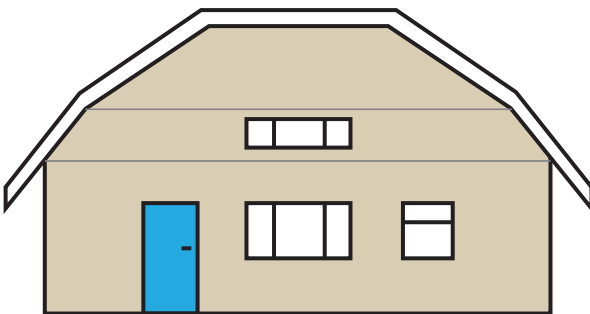

- (f) What is the pitch of the vertical walls of the houses?

6.3 Switching between pitch angles and different roof length ratios with the sine, cosine, and tangent functions

We are going to make use of six mathematical functions. These can be used to determine roof lengths and pitch angles, as you will see.

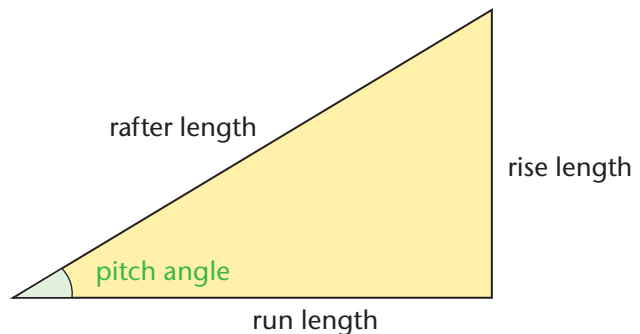

The **sine function** with the pitch angle as input, gives as output the ratio of the rise length and rafter length of the roof, with the ratio rise length : rafter length = $\frac{\text{rise length}}{\text{rafter length}}$

$$\sin \text{pitch angle} = \frac{\text{rise length}}{\text{rafter length}}$$

The **cosine function** with the pitch angle as input, gives as output the ratio of the run length and rafter length of the roof, with the ratio run length : rafter length = $\frac{\text{run length}}{\text{rafter length}}$

$$\cos \text{pitch angle} = \frac{\text{run length}}{\text{rafter length}}$$

The **tangent function** with the pitch angle as input, gives as output the ratio of the rise length and run length (pitch ratio) of the roof, with the ratio rise length : run length = $\frac{\text{rise length}}{\text{run length}}$

$$\tan \text{pitch angle} = \frac{\text{rise length}}{\text{run length}}$$

If you carefully consider the above three function definitions you would notice that they are each a relationship of three properties of the roof pitch, hence specific values can be calculated, e.g. if you have a pitch angle and a rise length then both rafter length and run length can be calculated using the sine and tangent functions.

Worked example Scale drawing – Constructing ratio outputs for sine, cosine and tangent from input angles

Problem: Suppose a particular roof has a pitch angle of 40° . Determine its roof length ratios by construction. In other words, determine the value of $\sin 40^\circ$, $\cos 40^\circ$, and $\tan 40^\circ$ by scale drawing:

Solution:

Step 1: Construct a horizontal line segment, OM, of any length, the longer the better (why?).

Step 2: Construct a ray perpendicular to OM at M.

Step 3: Construct a ray from O at the required angle, here 40° .

Step 4: Label the point N where the two rays cut; we now have a right-angled $\triangle OMN$.

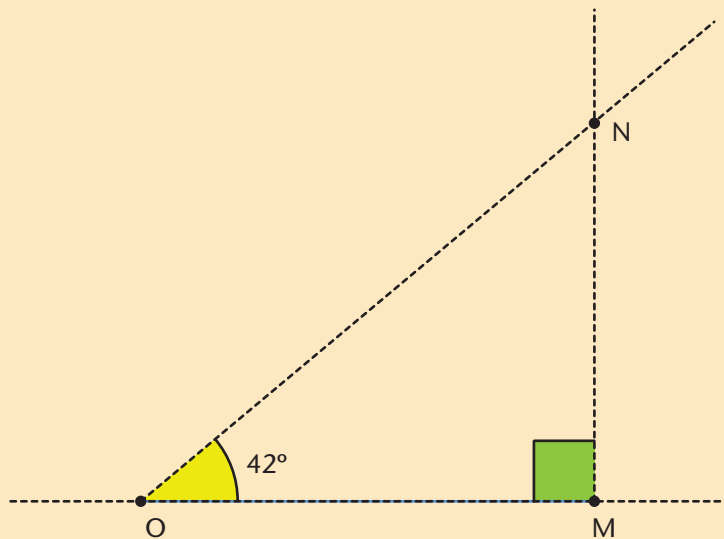

Step 5: Measure lengths MN, ON, and OM on your construction.

If you use your measurements, you can confirm that the following is true for all $\triangle OMN$:

The rise length and rafter length ratio (*rise: rafter*) will be

$$MN: ON = \sin 40^\circ = 0,64$$

The run length and rafter length ratio (*run: rafter*) will be $OM: ON = \cos 40^\circ = 0,77$

The pitch ratio (*rise: run*) will be $MN: OM = \tan 40^\circ = 0,84$

Convention: There are different conventions for writing the trigonometric functions and their input values. One is to use brackets: $\sin 60^\circ$. As you will see shortly, this is the convention used by your calculator and in other electronic formats. This is true function notation. However, we will follow the convention of writing $\sin 60^\circ$, without the brackets.

Worked example

The inverse question: constructing angle outputs for ratio inputs

Problem: A roof has a rise to run ratio of 2 cm to every 7 cm, i.e. a ratio $2:7 = 0,29$. Determine the pitch angle of the roof by scale drawing.

Solution:

Step 1: construct OM as before, say 10 cm long.

Step 2: construct a ray perpendicular to OM at M.

Step 3: construct point N $2,9\text{cm} \left(\frac{2}{7} \times 10\text{ cm} = 2,9\text{ cm} \right)$ from M along the ray.

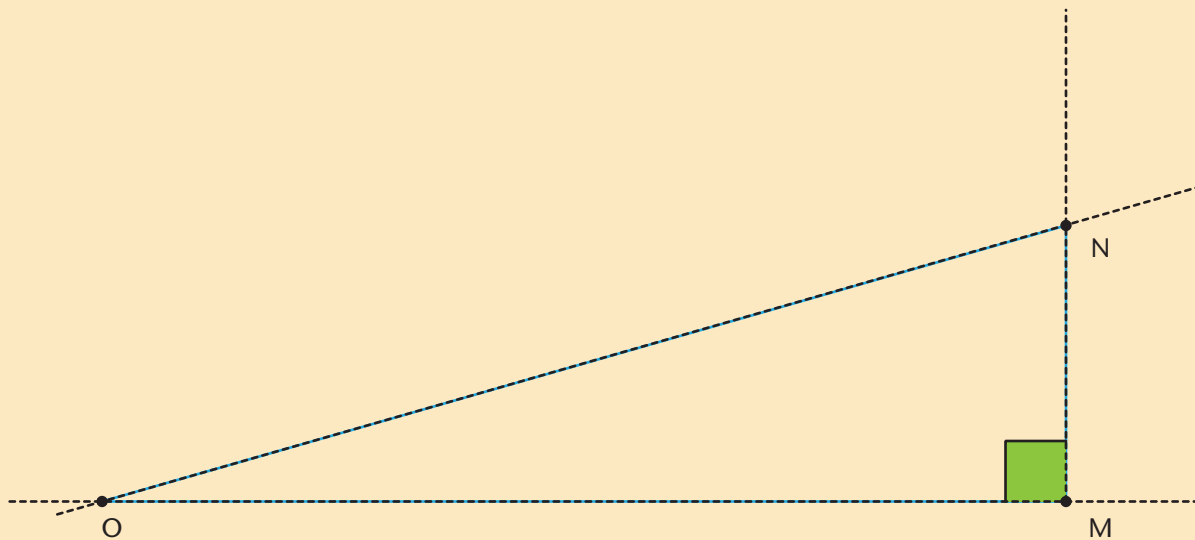

Step 4: join O and N.

Step 5: measure the $\triangle NOM$.

Your pitch angle measurement should be close to 16° .

Using the \tan^{-1} function and the pitch ratio of $2:7$ ($0,29$), the roof's pitch angle can be calculated as $\tan^{-1}(0,29) = 16^\circ$

Exercise Practise constructing inputs and outputs

- 4 Find the missing inputs and outputs for the sine, cosine, and tangent functions in the following right-angled triangles by scale drawing.

Important: In this question we are no longer talking about roof pitch. We have been using the roof situation as a *way into* trigonometry. Use your understanding of what we have done in that context to solve these.

- (a) Determine θ to one decimal place

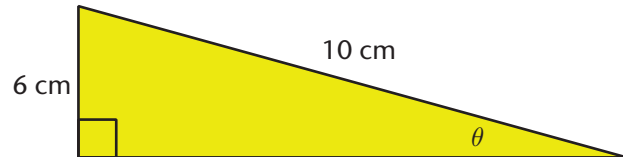

- (b) Determine α to one decimal place

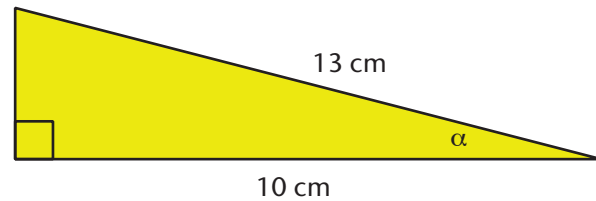

- (c) Determine θ to one decimal place

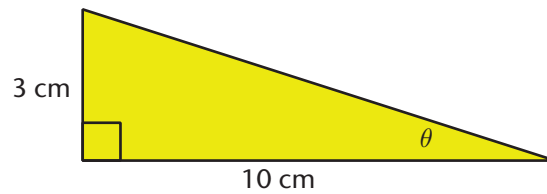

- (d) Determine a given that $\frac{a}{b} = \frac{2}{13}$

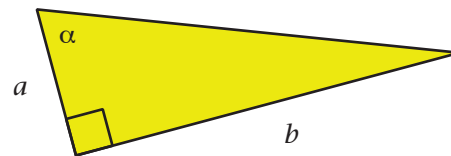

- (e) Determine $p:q$ in decimal form, rounded to two decimal places

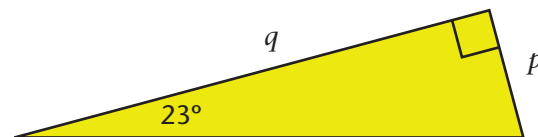

- (f) Determine $p:q$ in decimal form, rounded to two decimal places

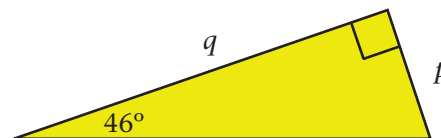

Calculating different values with the trigonometric functions

Each of the three trigonometric functions above is a calculation involving 2 lengths and an angle. This means that for a specific situation the **sine function** can be used to calculate the:

- rise length using $\text{rise length} = \text{rafter length} \times \sin \text{pitch angle}$, if the **rafter length** and **pitch angle** are known
- rafter length using $\text{rafter length} = \frac{\text{rise length}}{\sin \text{pitch angle}}$, if the rise length and pitch angle are known,

To calculate the **pitch angle** when the rise and rafter lengths are known, we use the sine function inverse – the arcsine function. The arcsine function is also known as \sin^{-1} . Most calculators use \sin^{-1} to denote the sine inverse function instead of arcsine.

This inverse function \sin^{-1} takes as input the ratio $\sin^{-1} \frac{\text{rise length}}{\text{rafter length}}$ of the roof's rise and rafter lengths $\frac{\text{rise length}}{\text{rafter length}}$, and outputs the pitch angle in degrees.

Therefore, pitch angle can be calculated:

- **pitch angle** using $\text{pitch angle} = \sin^{-1} \frac{\text{rise length}}{\text{rafter length}}$, if the **rise** and **rafter lengths** are known.

Trigonometric functions are very important. They are so important that they have been included in your calculator's collection of functions.

- Have a look on your calculator.
- Find the sin, cos, and tangent buttons.
- Notice that it says \sin^{-1} , \cos^{-1} , and \tan^{-1} just above.

You can switch between ratios and angles in right-angled triangles very easily using your calculator.

Important: First make sure that your calculator is set to degrees: You will see a little 'D' on your display confirming it is in degree mode. (Make sure to read your calculator's user manual or ask your teacher to assist you.)

Note: f^{-1} is a way mathematicians show the inverse function of a function: the function that swaps inputs and outputs. This can be very confusing because we use the same notation to show the reciprocal of a number. So, be clear that the ' -1 ' in ' \sin^{-1} ' does not represent a power, like in exponents, but rather the inverse of the sine function.

Note: Degree measure divides a full revolution into 360° of rotation. Radian measure divides a full revolution into 2π units, or 2π rad (See Chapter 10). Gradian measure divides a full revolution into 400 units, or 400 grad. In this chapter, we will only do trigonometry with angles in degrees.

Worked example

Problem: Calculate the unknown sides, n and p , of the right-angled triangle:

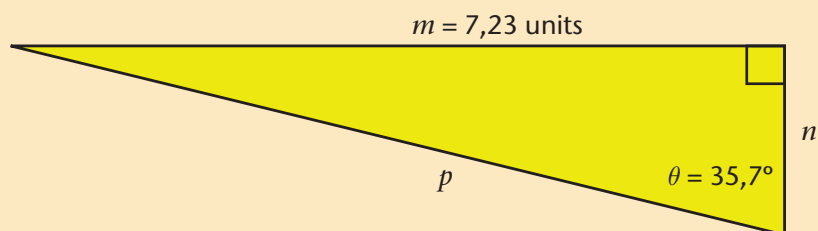

Solution: (rounding to two decimal places)

Step 1: m is opposite to the angle θ (orientate yourself in the triangle)

Step 2: decide which of p or n to calculate first (it doesn't matter!); we'll choose p

Step 3: decide which trigonometric function involves p and m ; since m is opposite and p is hypotenuse in terms of the angle θ , the trigonometric function must be $\sin \theta$.

Step 4: write down the correct relationship between p , m , and θ , and calculate p :

$$\begin{aligned}\frac{m}{p} &= \sin \theta \\ \frac{7,23}{p} &= \sin 35,7^\circ \\ p &= \frac{7,23}{\sin 35,7^\circ} \\ &= 12,38987043\dots \text{ units}\end{aligned}$$

Step 5: calculate n

Approach 1: use trigonometry

$$\begin{aligned}\tan \theta &= \frac{m}{n} \\ \tan 35,7^\circ &= \frac{7,23}{n} \\ n &= \frac{7,23}{\tan 35,7^\circ} \\ &= 10,06160968\dots \text{ units} \approx 10,06 \text{ units}\end{aligned}$$

Approach 2: use the Pythagorean Theorem:

$$\begin{aligned}n^2 + m^2 &= p^2 \\ n^2 &= p^2 - m^2 \\ n &= \sqrt{(12,39)^2 - (7,23)^2} \\ &= 10,06 \text{ units}\end{aligned}$$

Note: there is no need to put the angle of $35,7^\circ$ in parentheses; your calculator understands that $35,7$ is the angle. You can put them in if you prefer to.

Exercise

5 Determine the unknown quantities in the following right-angled triangles. Take care to set your work out neatly, in an organised fashion, as was done in the worked examples (round your final numerical answers to one decimal place).

(a) s and then t

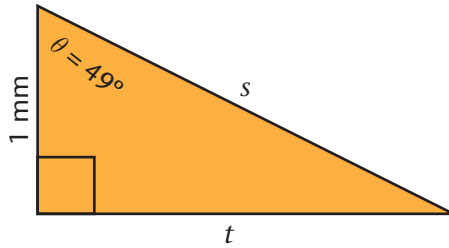

(b) d then $\cos \alpha$

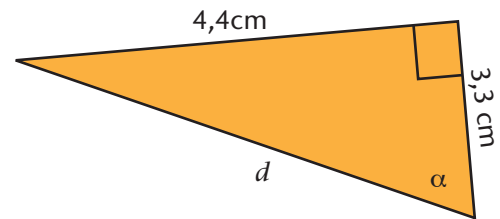

(c) θ and then z

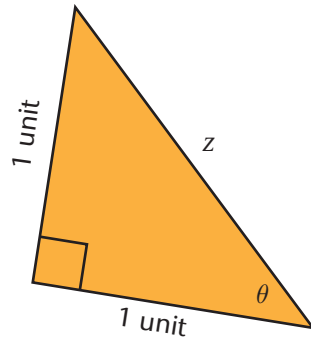

(d) x and y without Pythagoras

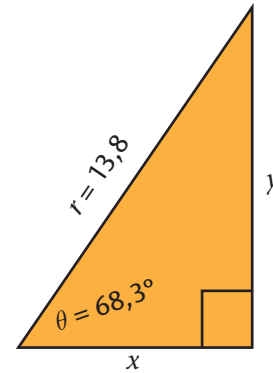

(e) θ , α and c (you decide the order)

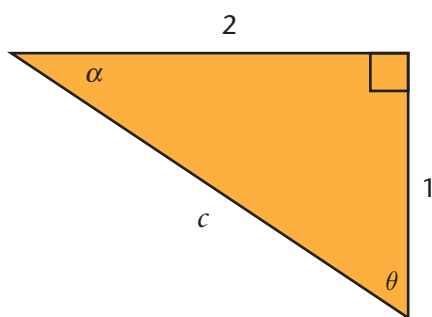

(f) Given $x:r = 4:5$ and $y = 2$. Determine x , r and β (you decide the order)

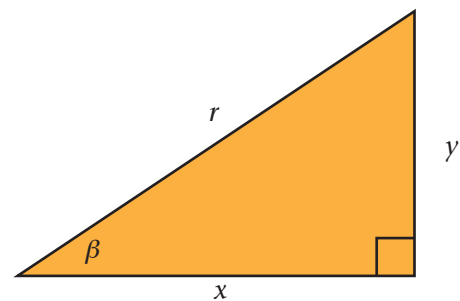

6.4 Right-angled triangles

The last exercise tells us something very important:

We can free ourselves from thinking only in terms of a situation, such as roof pitch, or any other.

This means we can use the sine, cosine, and tangent functions on *any right-angled triangle*. It is a tool for calculating a ratio from an acute angle.

Conventional names for the sides of right-angled triangles

We give special names to the sides of right-angled triangles. You may know these names:

- **Hypotenuse:** the side opposite the right angle; it is always the longest side of a right-angled triangle (why?).

In trigonometry, we need a way of distinguishing between the two sides. To do this, we give the sides different names. The names are not fixed. They depend on which of the two acute angles we are referring to:

- **Opposite side:** opposite to the angle
- **Adjacent side:** next to the angle; it forms one of the arms of the angle

The naming conventions are illustrated in the following diagram. On the left, we are assuming that the acute angle, α is the one we are interested in. On the right, we assume the other acute angle, β , is the one we are looking at.

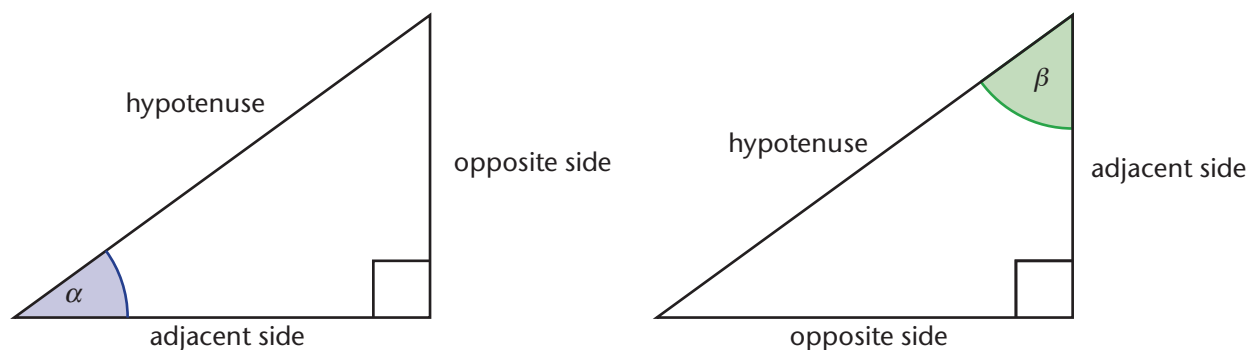

To make our writing less, we use the following abbreviations when referring to the different sides of a right-angled triangle:

- Opposite: *opp* or O – the side opposite the angle
- Adjacent: *adj* or A – the side adjacent to the angle
- Hypotenuse: *hyp* or H – the side opposite the right angle

Important question:

Why right-angled triangles?

Why not other triangles?

Very long ago, mathematicians agreed to focus on the relationship between angles and ratios of sides in right-angled triangles.

This was done because it makes the resulting mathematics the easiest and clearest (remember, for instance, that right-angled triangles obey the Pythagorean Theorem).

Also, it turns out that we can imagine non-right-angled triangles to be made up of two right-angled triangles.

Also, any polygon can be imagined as being made up of triangles. So, any flat polygon can be broken into right-angled triangles as well.

The two lines that form an angle are called the arms of the angle.

The word 'adjacent' means 'next to'. Who are you sitting adjacent to right now?

Exercises Getting used to the naming conventions

- 6 For each of the four right-angled triangles below, name the sides according to the naming conventions, using the given angle as reference (indicate hypotenuse, opposite, and adjacent in relation to given angle):

(a)

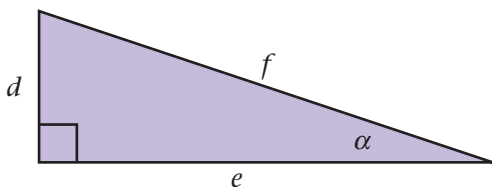

(b)

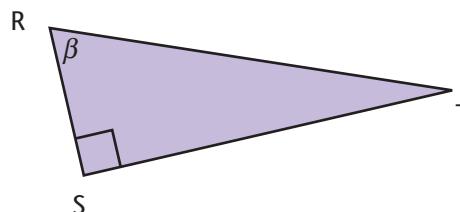

(c)

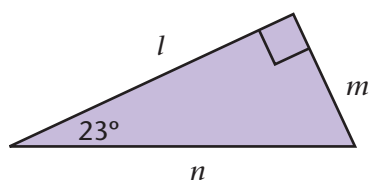

(d)

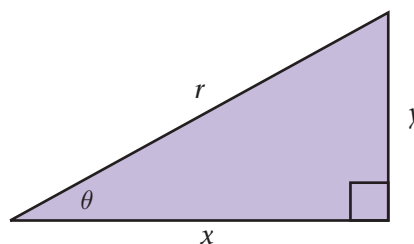

- 7 Construct $\triangle ABC$ with $\hat{B} = 90^\circ$, $\hat{A} = 36^\circ$, and $AB = 15$ cm.

- Measure the side BC to the nearest mm.
 - Use the lengths of the sides AB and BC to calculate the length of the side AC to the nearest mm. Confirm your calculation by measuring AC .
 - Identify the hypotenuse, the leg adjacent to \hat{A} and the leg opposite to \hat{A} .
 - What is the size of \hat{C} ?
 - Repeat question (c), using \hat{C} instead of \hat{A} . Compare what you have just done with what you did in (c).
 - Determine all possible ratios of pairs of the sides correct to two decimal places.
 - Suppose you draw $\triangle ABC$ with the same angles but with $AB = 30$ cm. Your answers in (f) should be the same. Give a reason why.
- 8 Think carefully about the following statements and decide if you agree with them:
- You are given an angle between 0° and 90° . You can construct a right-angled triangle with the given angle. You can then determine all six possible ratios of the sides.
 - The size of the triangle you draw in (a) doesn't matter but the angles must be the same. All the triangles you can possibly draw will be similar to each other.
 - You are given the ratio between any two sides of a right-angled triangle. You can use the ratio to construct a right-angled triangle. You will now be able to determine the acute angles in the triangle as well as the other ratios of the sides.
 - The size of the triangle you draw in (c) doesn't matter. Only the ratios of corresponding sides must be the same. All the triangles you can possibly draw will be similar to each other.

6.5 Defining the trigonometric functions

Definition: The **sine function** for right-angles triangles: $\sin \theta = \frac{opp}{hyp}$.

In words: the sine function relates an input angle θ to the correct output ratio $opp : hyp$, the ratio of the length of the opposite side to the length of the hypotenuse.

Definition: The **cosine function** for right-angled triangles: $\cos \theta = \frac{adj}{hyp}$.

In words: the cosine function relates an input angle θ to the correct output ratio $adj : hyp$, the ratio of the length of the adjacent side to the length of the hypotenuse.

Definition: The **tangent function** in right-angled triangles: $\tan \theta = \frac{opp}{adj}$.

In words: the function tangent relates an input angle θ to the correct output ratio $opp : adj$, the ratio of the length of the opposite side to the length of the adjacent side.

Defining the three basic trigonometric functions for right-angled triangles

To summarise, for a given right-angled triangle the basic trigonometric functions in right-angled triangles:

$$\sin \theta = \frac{\text{opposite}}{\text{hypotenuse}}$$

$$\cos \theta = \frac{\text{adjacent}}{\text{hypotenuse}}$$

$$\tan \theta = \frac{\text{opposite}}{\text{adjacent}}$$

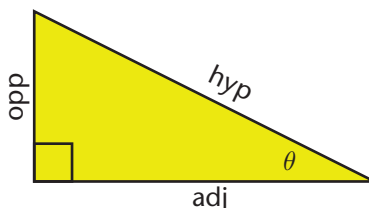

Defining the inverse trigonometric functions for right-angled triangles

We also define the ‘inverse functions’ of sine, cosine, and tangent, in right-angled triangles. These functions take as input the *adj*-, *opp*-, and *hyp*-ratios, and output the corresponding angles.

Using the inverse functions, the angle θ is calculated in three different ways:

$$\theta = \arcsin \frac{opp}{hyp} = \sin^{-1} \frac{opp}{hyp}$$

$$\theta = \arccos \frac{adj}{hyp} = \cos^{-1} \frac{adj}{hyp}$$

$$\theta = \arctan \frac{opp}{adj} = \tan^{-1} \frac{opp}{adj}$$

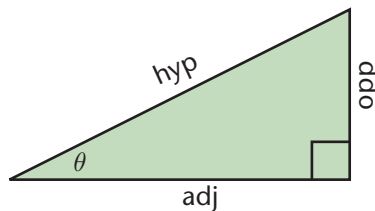

Notation: we will use the notation \sin^{-1} , \cos^{-1} , and \tan^{-1} rather than the arc functions, although they are the same functions and these are also indicated on most calculators as \sin^{-1} , \cos^{-1} , and \tan^{-1} .

To summarise, inverses of the basic trigonometric functions in right-angled triangles that enables you to calculate the right triangle sides' corresponding angles, are:

$$\theta = \sin^{-1} \frac{\textit{opposite}}{\textit{hypotenuse}}$$

$$\theta = \cos^{-1} \frac{\textit{adjacent}}{\textit{hypotenuse}}$$

$$\theta = \tan^{-1} \frac{\textit{opposite}}{\textit{adjacent}}$$

Defining the trigonometric reciprocal functions for right-angled triangles

The three basic trigonometric functions each have a sister function. They are defined using the reciprocal ratios used for the basic functions:

Definition: The **cosecant function** for right-angles triangles: $\text{cosec } \theta = \frac{\textit{hyp}}{\textit{opp}}$.

In words: the cosecant function relates an input angle θ to the correct output ratio $\textit{hyp} : \textit{opp}$, the ratio of the length of the hypotenuse to the length of the opposite side.

Definition: The **secant function** for right-angled triangles: $\text{sec } \theta = \frac{\textit{hyp}}{\textit{adj}}$.

In words: the secant function relates an input angle θ to the correct output ratio $\textit{hyp} : \textit{adj}$, the ratio of the length of the hypotenuse to the length of the adjacent side.

Definition: The **cotangent function** in right-angled triangles: $\text{cot } \theta = \frac{\textit{adj}}{\textit{opp}}$.

In words, the cotangent function relates an input angle θ to the correct output ratio $\textit{adj} : \textit{opp}$, the ratio of the length of the adjacent side to the length of the opposite side.

To summarise, for a given right-angled triangle the basic trigonometric functions' reciprocals in right-angled triangles are:

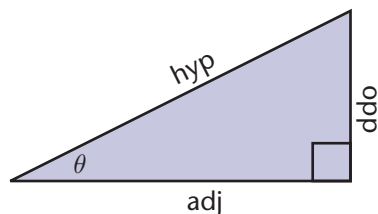

$\text{cosec } \theta =$ meaning that $\text{cosec } \theta$ is the same as $\frac{1}{\sin \theta}$

$\text{sec } \theta =$ meaning that $\text{sec } \theta$ is the same as $\frac{1}{\cos \theta}$

$\text{cot } \theta =$ meaning that $\text{cot } \theta$ is the same as $\frac{1}{\tan \theta}$

The statements on the right are *identities*. In other words, we are saying that $\text{cosec } \theta$ is identical to the reciprocal of $\sin \theta$ for all values of θ . This is actually almost true. There are some (very few) values of θ where the two are not identical. You can investigate what happens when θ is 0° or 90° for the three identities.

The full names of these functions are cosecant, secant, and cotangent.

Make sure you are clear which ratios go with which function. If you want a quick way of memorising sine, cosine, and tangent ratios:

SOH CAH TOA

Or more to the point:

Studying Our Homework Can Always Help To Obtain Achievement

That may look a bit silly. Maybe it is better if you figure out your own way of correctly remembering the definitions.

Whatever you choose to do, you must know the definitions before continuing with the rest of the chapter.

Exercises

- 9 Some routine practice to get used to the definitions. NB: first memorise the definitions. Do not keep looking back at the previous page. You will learn very little that way:

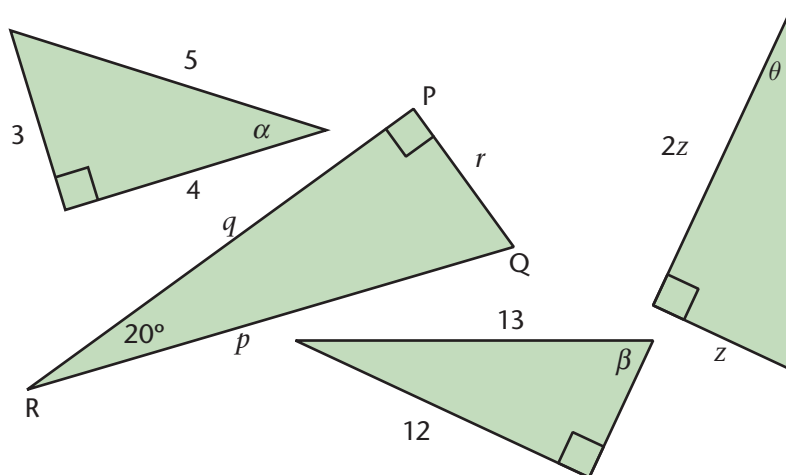

Determine the following. In the case of ratios, give them in rational form as well as decimal form where possible. If you are awake you will learn some things too!

- | | | |
|--|--|--|
| (a) $\sin \alpha$ | (b) $\cos \alpha$ | (c) $\sin \beta$ |
| (d) $\cos \beta$ | (e) $\tan \theta$ | (f) $\tan (90^\circ - \theta)$ |
| (g) $\sin 20^\circ$ | (h) $\sin (90^\circ - \alpha)$ | (i) $\tan \beta$ |
| (j) $\cos \theta$ | (k) $\cos \alpha$ | (l) $\tan 20^\circ$ |
| (m) $\cos \alpha$ | (n) $\tan 70^\circ$ | (o) $\tan^{-1} \left(\frac{3}{4} \right)$ |
| (p) $\cos^{-1} \left(\frac{q}{p} \right)$ | (q) $\sin^{-1} \left(\frac{4}{5} \right)$ | (r) $\tan^{-1} \left(\frac{1}{2} \right)$ |
| (s) $\sin^{-1} \left(\frac{12}{13} \right)$ | (t) $\tan^{-1} \left(\frac{4}{3} \right)$ | (u) $\cos^{-1} (0,6)$ |
| (v) $\cos^{-1} \left(\frac{12}{13} \right)$ | (w) $\tan^{-1} (2,4)$ | |

- 10 Go back to your constructions (scale drawings) in Exercise 4. Determine the sine, cosine, and tangent of the angles in each of the triangles. You may have to make some extra measurements on your scale drawings to do this.
- 11 Refer to Exercise 9. Express the following in terms of the information given in the triangles (apply the definitions directly – memorise them first!)
- | | |
|----------------------------------|-----------------------------------|
| (a) $\cot \alpha$ | (b) $\sec \alpha$ |
| (c) $\operatorname{cosec} \beta$ | (d) $\sec \beta$ |
| (e) $\cot \theta$ | (f) $\cot (90^\circ - \alpha)$ |
| (g) $\sec 20^\circ$ | (h) $\operatorname{cosec} \alpha$ |
| (i) $\cot \beta$ | (j) $\sec \theta$ |
| (k) $\sec (90^\circ - \theta)$ | (l) $\cot 20^\circ$ |
| (m) $\sec 70^\circ$ | (n) $\cot 70^\circ$ |

Some advice: The simplest way to deal with all three of these functions is to write them in terms of the other three, basic functions, sine, cosine, and tangent. You will see that we do this in all the examples that follow.

Calculating longer expressions involving trigonometric functions

Worked example

Problem: Calculate $\frac{\cos (2 \times 30^\circ - 12^\circ)}{3 \tan 21,4^\circ + 0,5}$ correct to two decimal places

Solution: Show your steps; sort out the numerator and denominator before you divide:

$$\begin{aligned} \frac{\cos (2 \times 30^\circ - 12^\circ)}{3 \tan 21,4^\circ + 0,5} &= \frac{\cos 48^\circ}{1,176 + 0,5} \\ &= \frac{0,669}{1,676} \\ &= 0,399 \\ &= 0,40 \end{aligned}$$

Note: The values in the steps are rounded to *three* decimal places.

This is to prevent a rounding error in the final answer. To be safe, always round off your values to more significant figures than you need for your final answer.

Exercise

12 Calculate the value of the following expressions correct to two decimal places:

(a) $\tan(3 \times 25^\circ)$

(b) $3 \tan 25^\circ$

(c) $\sin \frac{45^\circ}{2}$

(d) $\frac{\sin 45^\circ}{2}$

(e) $\cos(13^\circ + 18^\circ)$

(f) $\cos 13^\circ + \cos 18^\circ$

(g) $\sin 20^\circ - \cos 70^\circ$

(h) $\tan 75^\circ - \frac{1}{\tan 15^\circ}$

(i) $\cos 53,2^\circ - \sin 36,8^\circ$

(j) $\tan 30^\circ - 3 \tan 10^\circ$

(k) Compare (a) and (b). Compare (c) and (d). Compare (e) and (f). Look at (j). What have you learned about trigonometric functions (about what they *cannot* do)?

(l) $\sin 32^\circ \cos 32^\circ + \frac{\sin(2 \times 32^\circ)}{\cos(90^\circ - 2 \times 32^\circ)}$

(m) $\frac{\cos 12^\circ \cos 80^\circ}{\cos 78^\circ \sin 31^\circ}$

(n) $\frac{\cos 12^\circ + \cos 80^\circ}{\cos 78^\circ + \sin 31^\circ}$

(o) If $\beta = 24,7^\circ$ calculate the value of $\sin 2\beta + 2\sin \beta + (\sin \beta)^2$

(p) If $a = 48^\circ$ and $b = 32^\circ$, calculate the value of $\left(\frac{\alpha + \beta}{2}\right) \sin \left(\frac{\beta - \alpha}{2}\right)$

Calculating with the reciprocal functions

Worked example

Problem: Calculate $\operatorname{cosec} 23^\circ$:

Solution: Since $\operatorname{cosec} 23^\circ = \frac{1}{\sin 23^\circ}$

$$\operatorname{cosec} 23^\circ = \frac{1}{\sin 23^\circ} = 2,56$$

Exercises

13 Use your calculator to determine the following:

(a) $\cot 45^\circ$

(b) $\operatorname{cosec} 23,8^\circ$

(c) $\sec 89^\circ$

(d) $\cot 13,2^\circ$

(e) $\sec 66,2^\circ$

(f) $\operatorname{cosec} 89^\circ$

(g) $\frac{\operatorname{cosec}(30^\circ - 2 \times 10^\circ)}{1 + \cos 73^\circ}$

(h) $\sec 25^\circ \times \cos 25^\circ$

(i) $\frac{\sec 55^\circ}{\operatorname{cosec} 55^\circ} + \tan 55^\circ$

(j) $\frac{\cot(4 \times 17^\circ) + 4}{4}$

(k) $\frac{\sin 42,7^\circ - \operatorname{cosec} 42,7^\circ}{\cot 11,9^\circ - \tan 11,9^\circ}$

14 Solve the following equations:

(a) $2 \tan x = 7$

(b) $\sec (2x + 21^\circ) = 7$

(c) $3 \sin x = 4$

(b) $4 \cos x = 1$

(d) $\frac{1 - 5,2}{62,3 + \frac{\cot \alpha}{3}} = 0,92$

(e) $5 \operatorname{cosec} \beta - 7 = 1 + 0,3 \operatorname{cosec} \beta$

(f) $\frac{2}{3} - \frac{\tan 5\beta}{7} = \frac{11}{\cot 5\beta}$

6.6 Input angles of 0° and 90°



So far, we have allowed sine, cosine, and tangent to take acute-angle inputs to produce ratio outputs for right-angled triangles.

We have left out inputs of 0° and 90° except for one or two hints. The reason is simple. It is impossible to draw a right-angled triangle with the remaining two angles 0° and 90° . If you don't believe this, try to construct one yourself.

But we should actually think about including them. Let us try to see why and how we can do this.

Exercise Looking back

15 Have a look at Exercise 3 again. In 3(e) the roof has two slanted pitches (this type of roof is called a mansard roof – the Parliament Building in Cape Town has one) and is *horizontal* on top.

- (a) What is the pitch angle of a horizontal, flat roof?
- (b) What is the pitch ratio (*rise : run* or *rise* ÷ *run*) for the horizontal roof?

In 3(f) you were asked what the pitch of a *vertical wall* is.

- (c) What is the pitch angle of a vertical wall?
- (d) We cannot calculate a pitch ratio for a vertical wall. Explain why not.

Important extra properties we want tangent to have

Based on the results of the above exercise, we need the tangent function to do the following:

- $\tan 0^\circ = 0$
- $\tan 90^\circ$ is undefined

How can we include these input-output pairs? We can't use triangles. It just needs us to see what is there in a different way, with no need for 'impossible' triangles.

6.7 The Cartesian grid: looking at the tangent function in a different way

Refer to the roof pitch situation again: the triangles are exactly the same ones we saw earlier. On the right, they have been placed onto a Cartesian grid, with the pitch angle vertex at the origin, the runs along the x -axis, and the rises parallel to the y -axis.

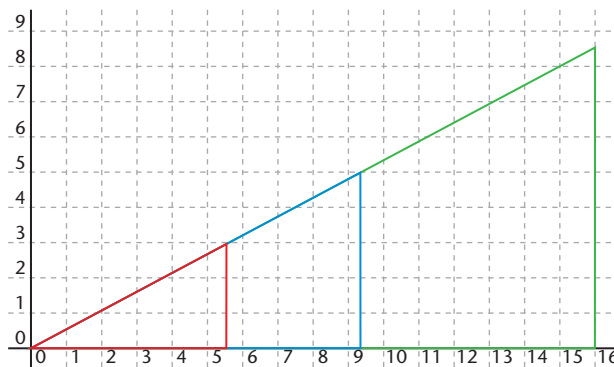

Here the Cartesian representation is enlarged (scaled up in proportion, so all length ratios are the same), and labelled:

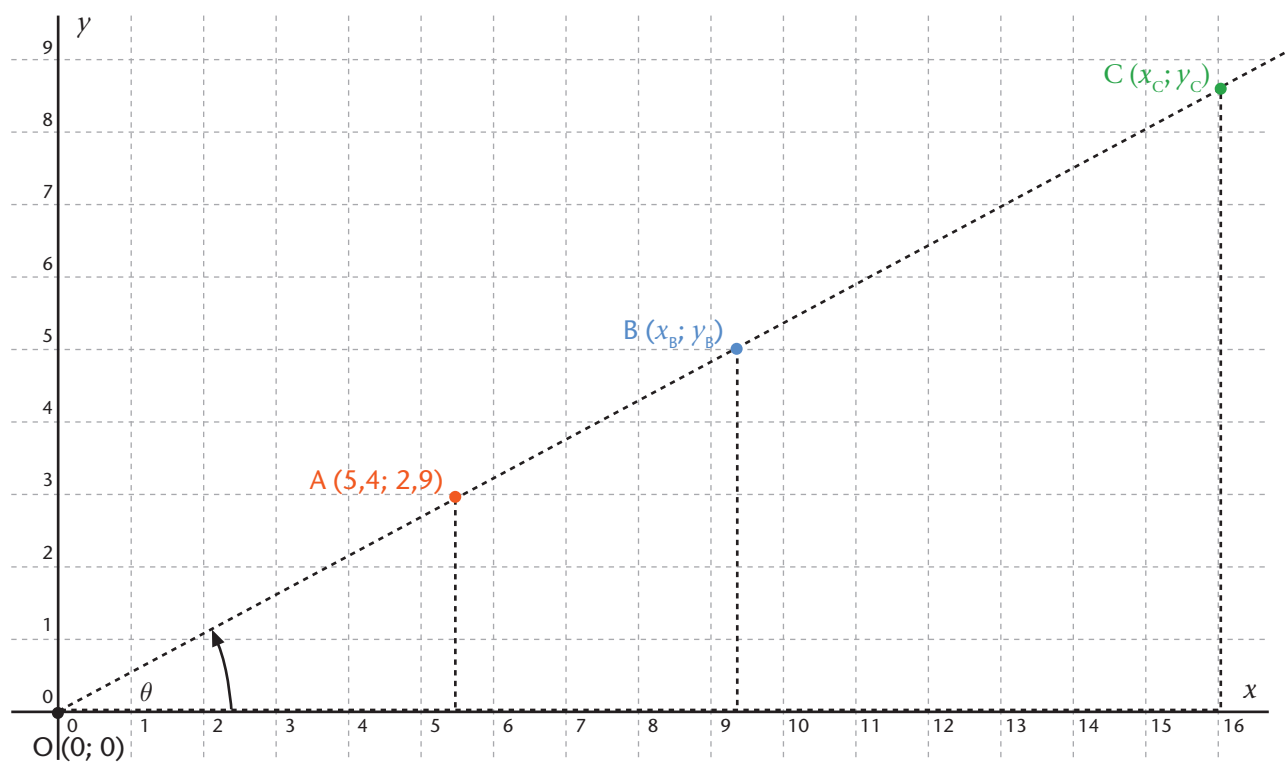

The three triangles are shown in black, while the coordinates of the top vertex are shown in the original colours.

This is to show that we are not really focusing on the triangles any more.

Rather, all the information we need is contained in the coordinates.

Note: we read something like x_A as 'x subscript A' or 'x sub A' for short. Writing the 'A' as a subscript is an easy way to show we are talking about the x-coordinate of point A. This notation is very useful when we want to refer to two or more points.

Worked example How to read off a Cartesian grid accurately

Problem: Reading x_A on the previous diagram.

Solution: You need a ruler and possibly a calculator.

Step 1: Determine the scale. To do this, use your ruler to measure any distance on the diagram, the longer the better, e.g. place your ruler on the x -axis with the zero at O. Measure the distance d from O to the point 16 units from O. The scale will be d cm:16 units.

Step 2: Measure the distance you need the reading of. For example here, measure the distance along the x -axis from O to x_A with your ruler.

Step 3: Use your scale to convert the distance on your ruler to the value of x_A on the Cartesian grid. You should get 5,4 units (as it is stated in the diagram).

Tangent function using the Cartesian system above with coordinates A, B, and C

Exercises

16 Answer the questions that follow:

- Determine the coordinates from the diagram above of points B and C as accurately as you can.
- Calculate the quotients, rounded to two decimal units:
 - $\frac{y_A}{x_A}$
 - $\frac{y_B}{x_B}$
 - $\frac{y_C}{x_C}$
- Re-measure the angle (just to be sure).
- Compare your results here to the results you got in Exercise 1. If you have worked carefully, you should get the same results. Are you surprised? Why are the results the same? Explain to yourself, or better, to someone else.

17 Let P be any point on the positive x -axis, and Q any point along the positive y -axis.

- What is the value of $\frac{y_P}{x_P}$?
- Can we calculate $\frac{y_Q}{x_Q}$?
- Compare your results here with your results in Exercise 16.

18 Comment on the following two statements:

‘We can combine what we see in Exercises 16 and 17 to say that: $\tan \theta = \frac{y}{x}$,

‘If we do this, the case when $\theta = 0^\circ$ is automatically included, while the case where $\theta = 90^\circ$ is automatically excluded, as we expect from Exercise 16.’

What have we learned from the previous exercises?

- The coordinate definition gives exactly the same results as the right-angled triangle definition when $0^\circ < \theta < 90^\circ$.
- The coordinate definition also gives us results we cannot get from the triangle definition when θ is 0° or 90° .

Measuring Angles around the origin of the Cartesian Plane

Convention:

- use the positive x -axis as the reference arm for the angle
- the ray extending from the origin forms the other arm of the angle
- measure the angle going anticlockwise from the reference arm to the other arm

Exercise Measuring angles from 0° to 360° in the Cartesian plane

19 Use your protractor, where necessary, to measure

- the angles α , β , θ and δ , and
- the five angles made by the positive and negative x - and y -axes. (**Hint:** the positive x -axis makes two different angles with itself according to the convention).

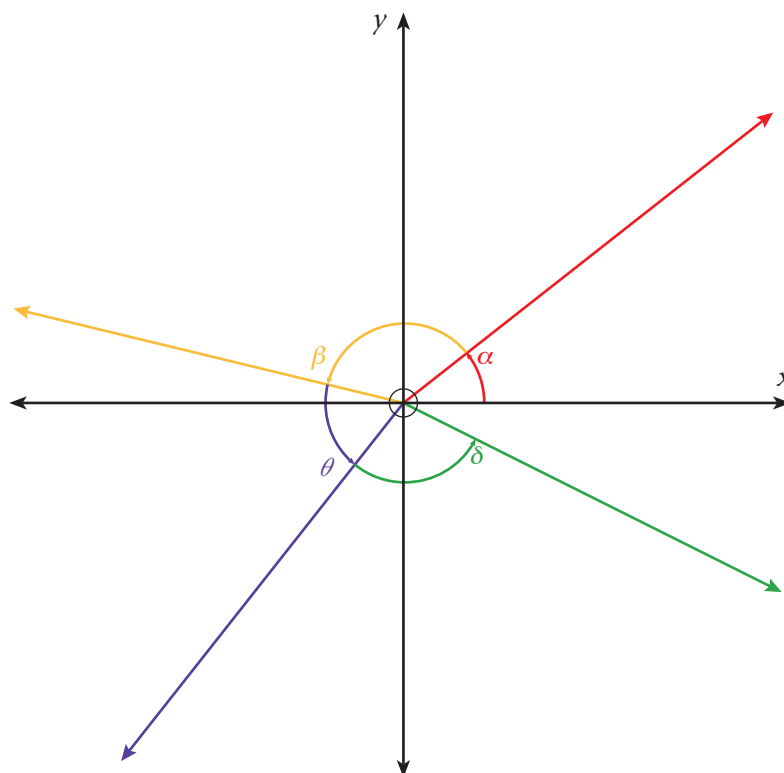

Hint: Be smart. Your protractor might only be able to measure some of these angles directly. Make a plan with the others.

6.8 More applications of trigonometric functions in the Cartesian plane

Example

When we are dealing with the trigonometry of right-angled triangles, the domain of the three basic functions is all the angles *between* 0° and 90° : $0^\circ < \theta < 90^\circ$.

The range of the sine and cosine functions is all the real numbers *between* -1 and 1 . The range of the tangent functions is all the positive real numbers. Make sure that you agree with this.

The Cartesian definition of the sine and cosine functions

The sine and cosine functions share very similar properties, so we will develop them side-by-side.

For any point in the Cartesian plane $P(x; y)$ that is *not* $(0; 0)$:

$$\sin \theta = \frac{y}{r} \text{ and } \cos \theta = \frac{x}{r} \text{ where } r = +\sqrt{x^2 + y^2} = OP$$

is the radial distance from the origin O to the point $P(x; y)$.

Properties of the general sine and cosine functions (understand and remember these)

Domain: The sine and cosine functions we have defined have exactly the same domain: all angles starting at 0° and ending at 360° .

Range: The range of the sine function and the range of the cosine function are identical, including all the real numbers starting at -1 and ending at 1 .

The sine function has:

- A. negative outputs *inside* quadrants 3 and 4, where y is negative,
- B. positive outputs *inside* quadrants 1 and 2, where y is positive,
- C. zero as output anywhere *along* the x -axis (y is zero everywhere along the x -axis) EXCEPT at zero, and
- D. it has a maximum output of $+1$ *along* the positive y -axis, and a minimum output of -1 *along* the negative y -axis (where $y = \pm r$ because $x = 0$).

The cosine function has:

- A. negative outputs *inside* quadrants 2 and 3, where x is negative,
- B. positive outputs *inside* quadrants 1 and 4, where x is positive,
- C. zero as output anywhere *along* the y -axis (i.e. where x is zero) EXCEPT at zero, and
- D. it has a maximum output of $+1$ *along* the positive x -axis, and minimum output of -1 *along* the negative x -axis (where $x = \pm r$ because $y = 0$).

These properties of the sine function and the cosine function are all summarised in the following two diagrams:

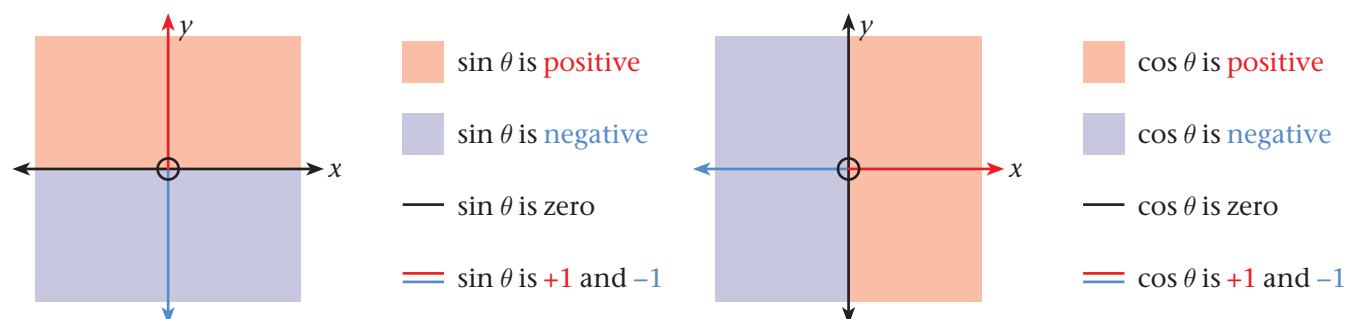

Exercise Looking back

20 Have a look at Exercise 3(e) again.

(a) What is the *rise : rafter length ratio*

- of a horizontal, flat roof?
- of a vertical wall?

Check that the Cartesian definition of sine gives the same results as you get here.

(b) What is the *run : rafter length ratio*

- of a horizontal, flat roof?
- of a vertical wall?

Check that the Cartesian definition of cosine gives the same results as you get here.

Important fact: The value of r is kept positive so that the sign of x gives the sign of the output of $\cos \theta$, and the sign of y gives the sign of the output of $\sin \theta$.

Properties of the general tangent function (understand and remember these)

Domain: The domain of the tangent function we have defined, includes all angles starting at 0° and ending at 360° , except the angles 90° and 270° .

Range: The range is any real number, including negative numbers.

The tangent function has:

- A. negative outputs *inside* quadrants 2 and 4,
- B. positive outputs *inside* quadrants 1 and 3,
- C. zero as output anywhere *along* the x -axis, EXCEPT at zero, and
- D. it has NO outputs *along* the y -axis (undefined here)

The Cartesian definition of the tangent function

For any point $P(x; y)$ in the Cartesian plane that is not on the y -axis: $\tan \theta = \frac{y}{x}$

These properties are all summarised in the following diagram:

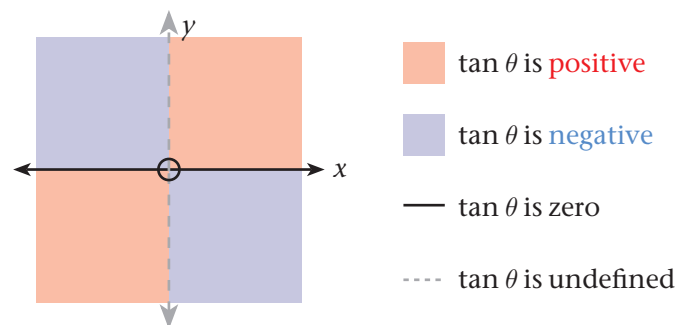

We don't usually give a sign to the pitch of a roof. But we do this for radii, pointing from the origin of the Cartesian plane. We could say that the 'pitch' of a radius inside quadrant 1 or 3 is positive, while the 'pitch' of a radius inside quadrant 2 or 4 is negative.

Exercises Getting to understand the Properties

21 Knowing the signs of the trigonometric functions in different quadrants is a *very useful tool*.

Here are some other ways to decide on the sign (+ or -) of the outputs of sine and cosine.

(a) Copy and complete by replacing the question marks with the correct inequality sign for the following diagram for points $(x; y)$ *inside* Q1, Q2, Q3, and Q4, noting that $r > 0$ (always, by definition):

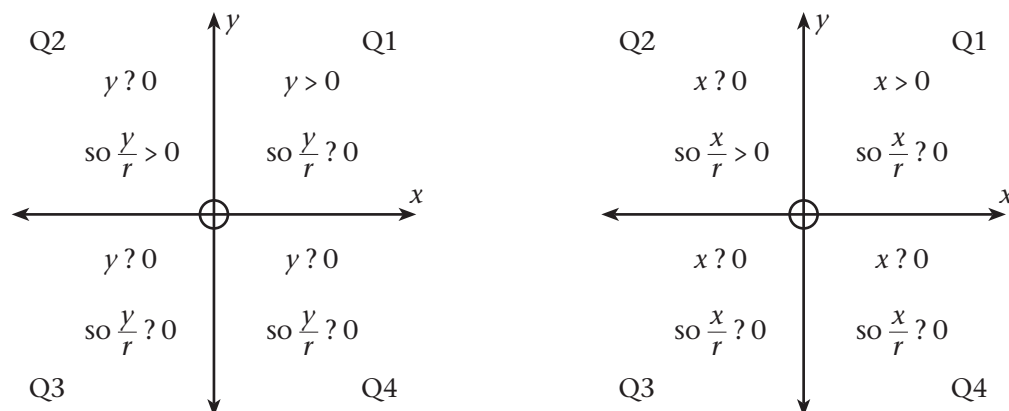

(b) Copy and complete the following table for points $(x; y)$:

$(x; y)$ inside quadrant:	sign of r :	sign of x :	sign of $x \div r$:	sign of y :	sign of $y \div r$:
1		+		+	+
2					-
3		-			
4				-	

(c) You can also use your calculator to find out the sign of the sine and cosine functions in different quadrants. Select a few test input angles from each quadrant and check that you get what is expected.

22 The diagram represents a Cartesian system with a circle of radius $r = 1$ unit, centred at the origin. Do the following without a calculator:

- Write down the x -coordinates of the four points A, B, C, and D. Use them to calculate the output values of the cosine function for inputs of 0° (360°), 90° , 180° , and 270° .
- Write down the y -coordinates of the points and use them to calculate the output values of the sine function at the five angles.

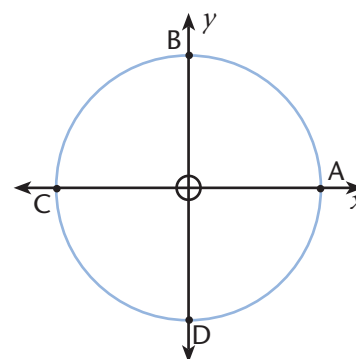

The following two questions require concentration. Imagine placing your finger on point A (or actually do it!) Now, imagine sliding it (or actually slide it) slowly along the circle through point B, C, D, and back to A.

- How does the value of the y -coordinate of your fingertip change as you:
 - slide it from A to B?
 - slide it from B to C to D?
 - slide it from D to A?
- How does the value of the x -coordinate of your fingertip change as you:
 - slide it from A to B to C?
 - slide it from C to D to A?

(Hint: Use the words ‘increases’, ‘decreases’, ‘positive’, and ‘negative’. Include the maximum values of 1, the minimum values of -1, and in between the values of 0.)

23 Other ways to decide the sign (+ or -) of the outputs of the tangent function:

(a) Copy and complete the following table for points $(x; y)$ that *do not* lie on the axes:

$(x; y)$ inside quadrant:	sign of x :	sign of y :	sign of $y \div x$:
1	+	+	+
2			-
3	-		
4		-	

(b) Copy and complete the diagram on the right for points $(x; y)$ inside Q1, Q2, Q3, and Q4 by replacing the question marks with the correct inequality signs.

(c) Make sure you are satisfied that you understand why the tangent function gives positive outputs inside Q1 and Q3, and negative outputs inside Q2 and Q4.

(d) You can also use your calculator to find out the sign of the tangent function in different quadrants. Play around with a few test-input angles and check that you get what you expect.

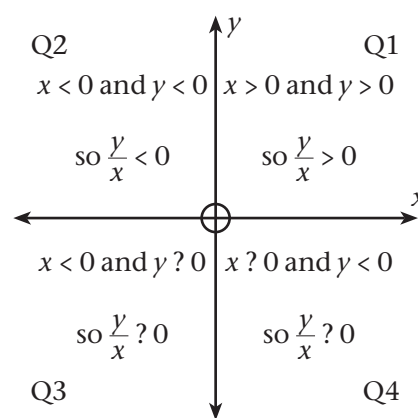

Calculating with the Cartesian definitions of the trigonometric functions

Exercises

24 Use your calculator to determine the output values of tangent for the following angles. State which quadrant the angle corresponds to. Check that the sign (+ or -) makes sense to you.

- | | |
|-----------------|-----------------|
| (a) 140° | (b) 285° |
| (c) 100° | (d) 269° |
| (e) 1° | (f) 179° |
| (g) 181° | (h) 359° |
| (i) 45° | (j) 135° |
| (k) 225° | (l) 315° |

25 Give at least three coordinates $(x; y)$ so that:

(a) $\frac{y}{x} = \tan 0^\circ$

(b) $\frac{y}{x} = \tan 180^\circ$

(c) $\frac{y}{x} = \tan 225^\circ$

(d) $\frac{y}{x} = \tan 135^\circ$

In each case, determine the three values of r corresponding to the three coordinates.

Could you give more than three coordinates in each case? How many more? Is there a limit to the number of coordinate pairs you can choose to write down?

26 The diagram represents a Cartesian system with a circle of radius 7,23 units centred at the origin.

(a) Make use of the diagram to determine the coordinates of points A, B, C, and D.

(b) Without using your calculator, use these coordinates to show that:

- $\tan 0^\circ$ and $\tan 180^\circ$ are zero, and
- that $\tan 90^\circ$ and $\tan 270^\circ$ are undefined.

(c) It doesn't matter what the radius of the circle is in question (b). Explain why it has no effect.

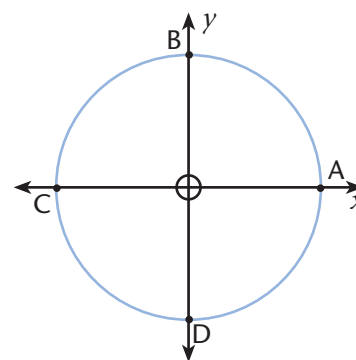

27 The diagram shows four points on the circumference of a circle.

(a) Explain why the angle for A is 45° .

(b) Give the angles of B, C, and D.

(c) Use the diagram and what you understand from (a) and (b) to show that:

- $\tan 45^\circ$ and $\tan 225^\circ$ are 1, and that
- $\tan 135^\circ$ and $\tan 225^\circ$ are -1.

(d) Calculate the radius of the circle. (**Hint:** look for a right-angled triangle and use the Pythagorean Theorem.)

(e) The radius of the circle makes no difference to the values of the tangent function in (c). Explain why it has no effect.

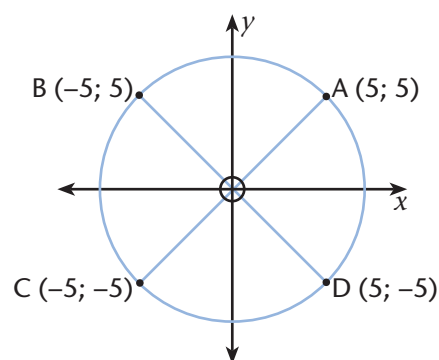

Worked example Finding the unknown coordinate

Problem: The diagram represents a Cartesian plane, but is not drawn to scale. What is the value of a ?

Solution: This is not a scale drawing, so we cannot measure the value of a off it.

Step 1: Identify the trigonometric ratio involved. We have y and we need to calculate x (here represented by a). So we must use \tan .

Step 2: Write down an equation and solve for a :

$$\begin{aligned}\tan 146^\circ &= \frac{2,5}{a} \\ a &= \frac{2,5}{\tan 146^\circ} \\ &= -3,706\ 402\ 421 \dots \\ &= -3,7\end{aligned}$$

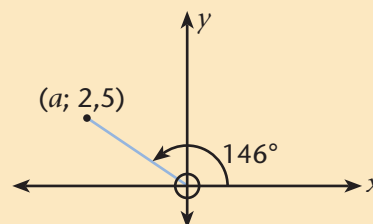

Worked example Finding the unknown angle

Problem: Determine the value of β in the following situation

Solution: As before, this is not to scale. So we must calculate.

Step 1: Since we are given x and y values, we know we will have to use \tan .

Step 2: We will use our understanding of trigonometry in right-angled triangles here. Begin by identifying a right-angled triangle in the diagram:

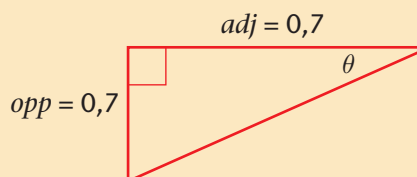
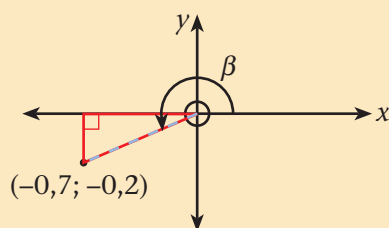
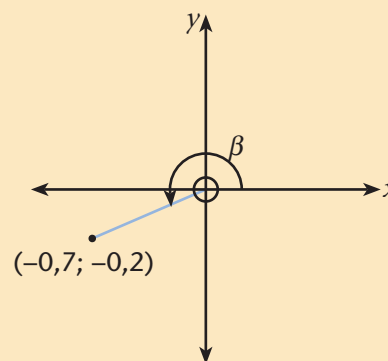

We have named the interior angle at the origin θ . The adjacent arm has the unsigned value of x and the opposite leg, the unsigned value of y .

Step 3: Calculate the value of θ :

$$\begin{aligned}\tan \theta &= \frac{0,2}{0,7} \\ &= \tan^{-1} \frac{0,2}{0,7} \\ &= 15,945\ 395\ 9 \dots^\circ \\ &= 15,9^\circ\end{aligned}$$

Step 4: Use θ to calculate β :

$$\beta = 180^\circ + \theta = 180^\circ + 15,9^\circ = 195,9^\circ$$

Note: unfortunately your calculator will not give you the value of β if you calculate $\tan^{-1} \left(\frac{y}{x} \right)$. It is worse for Q2 and Q4. Try calculating \tan^{-1} of a negative ratio of y to x . It will give a negative angle. The approach given in this example is the clearest.

Something important: In the introduction to the chapter it was mentioned that there is a link between the roof pitch situation and the Ferris wheel situation. This link is visible in Step 2, where the Cartesian situation has been re-interpreted as a triangle situation.

The following exercises make use of that link. Part of the skill of trigonometry is to be able to see right-angled triangles in Cartesian problems.

Exercises Finding missing angles and coordinates

28 Calculate the missing x - or y -coordinate or angle θ (measured from the positive x -axis) for the following points in the Cartesian plane. In each case, begin by representing the information on a sketch Cartesian system, as in the examples.

- | | |
|--|--|
| (a) $(x; y) = (-3; 2); \theta = ?$ | (b) $(x; y) = (6, 7; ?); \theta = 285^\circ$ |
| (c) $(x; y) = (?; 0,88); \theta = 104,8^\circ$ | (d) $(x; y) = (-4,8; -1,3); \theta = ?$ |
| (e) $(x; y) = (2; 0,25); \theta = ?$ | (f) $(x; y) = (?; -0,079); \theta = 234^\circ$ |

29 O is at the origin and O, P, and Q lie in a straight line.

Calculate:

- the missing coordinate m ,
- the angle θ , and
- the lengths OP and PQ. (**Hint:** $PQ = OQ - OP$).

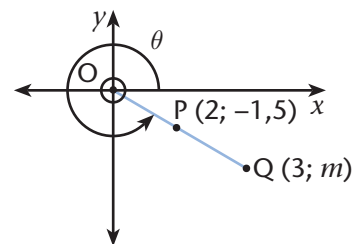

- 30 Go back to the soccer field example at the beginning of paragraph 6.2. Let O be the origin of a Cartesian grid. Let OM be the positive x -axis. Let OR extended be the positive y -axis. The pitch is size is 100 m by 70 m (so, e.g. point M has $x = 100$ m).
- Write down the coordinates of M, P, θ , R, and S.
 - Write down the values of θ for positions M, R, and S. Also write down the values of OM, OR, and OS.
 - Calculate the value of θ and OQ for the position Q. Do this by first representing the problem information on a sketch system of axes. Show your calculation steps.
 - Use your answer in (c) to write down the values of θ and OP for position P. Explain how you get your values.
 - Do you have to use the coordinate definitions of the trigonometric functions to solve the previous questions?

The Cartesian definitions of cosecant, secant, and cotangent

These are defined, as in right-angled triangles, as the reciprocals of $\sin \theta$, $\cos \theta$, and $\tan \theta$:

$$\operatorname{cosec} \theta = \frac{r}{y} \quad \text{undefined at } y = 0; \text{ the same as saying when } \theta = 0^\circ; 180^\circ; 360^\circ$$

$$\operatorname{sec} \theta = \frac{r}{x} \quad \text{undefined at } x = 0; \text{ the same as saying when } \theta = 90^\circ; 270^\circ$$

$$\operatorname{cot} \theta = \frac{x}{y} \quad \text{undefined at } y = 0; \text{ the same as saying when } \theta = 0^\circ; 180^\circ; 360^\circ$$

Check the statements next to the definitions, saying where the functions are undefined. Make sure you agree with them.

Worked example Ratio outputs from coordinates

Problem: The point T $(-6; -8)$ is at an angle α to the positive x -axis. Determine $\sin \alpha$, $\sec \alpha$, and $\cot \alpha$.

Solution:

Step 1: Represent the situation in a sketch:

Step 2: We need r to calculate $\sin \alpha$ and $\sec \alpha$

Identify a right-angled triangle in your Cartesian representation and use the Pythagorean Theorem:

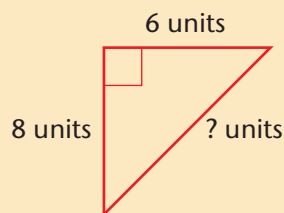
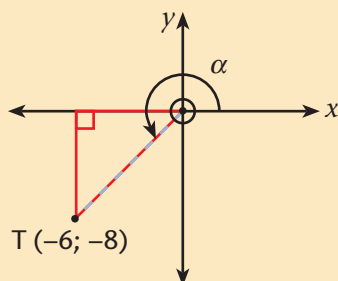
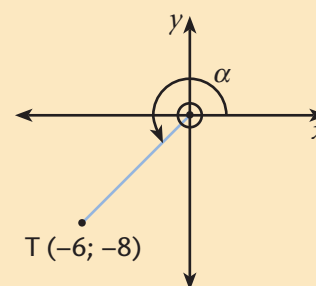

The legs of the right-angled triangle have lengths 6 units and 8 units (we get these from the coordinate values).

So, the hypotenuse has length $\sqrt{6^2 + 8^2} = 10$ units

So, in the Cartesian representation in the left, $r = 10$.

Step 3: Calculate the three ratios using the definitions:

$$\sin \alpha = \frac{y}{r} = \frac{-8}{10} = -\frac{4}{5} \text{ or } -0,8 \text{ exactly if you prefer decimal.}$$

$$\sec \alpha = \frac{r}{x} = \frac{10}{-6} = -\frac{5}{3} \text{ or } -1,67 \text{ rounded to two decimal places in decimal.}$$

$$\cot \alpha = \frac{x}{y} = \frac{-6}{-8} = \frac{3}{4} \text{ or } 0,75 \text{ exactly in decimal.}$$

Check that you are satisfied with the signs of the values by checking that they fit with the properties.

Exercises Practise determining outputs from coordinates

31 Calculate $\sin \theta$, $\cos \theta$, $\tan \theta$, and their reciprocals for the following points:

- (a) $(x; y) = (2, 5; -7, 5)$
- (b) $(x; y) = (0, 16; 0, 12)$
- (c) $(x; y) = (-1; 4)$
- (d) $(x; y) = (-2, 5; -7, 5)$
- (e) $(x; y)$ in the second quadrant with $y = 5,34$ and $r = 7,65$
- (f) $(x; y)$ in the fourth quadrant with $x = 1,1$ and $r = 1,5$
- (g) $(x; y)$ in the third quadrant with $x = -5$ and $r = 13$
- (h) $(x; y)$ in the second quadrant with $y = 0,33$ and $r = 0,77$

32 Use your calculator to determine the following (round to 2 decimal places):

- | | | |
|------------------------|------------------------|------------------------|
| (a) $\sin 92,81^\circ$ | (b) $\sin 219,4^\circ$ | (c) $\sin 30^\circ$ |
| (d) $\sin 150^\circ$ | (e) $\sin 210^\circ$ | (f) $\sin 330^\circ$ |
| (g) $\cos 92,81^\circ$ | (h) $\cos 219,4$ | (i) $\cos 88,3^\circ$ |
| (j) $\cos 91,7^\circ$ | (k) $\cos 266,3^\circ$ | (l) $\cos 271,7^\circ$ |

33 Calculate the values of $\sin \alpha$ and $\cos \alpha$ for $\alpha = 45^\circ$, 135° , 225° , and 315° .

34 For which values of β will $\sin \beta = \cos \beta$?

Worked example Finding the unknown angle

Problem: Point α lies in the third quadrant, a distance 5,3 units from the origin and has a y -coordinate $-4,1$. Determine the value of β , its angular position, to the nearest tenth of a degree:

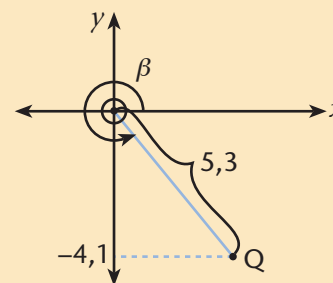

A. Standard solution

Step 1: Identify the trigonometric ratio. We are given y and r , so we know we will be able to use sine.

Step 2: Use the trigonometry of right-angled triangles. Identify the right-angled triangle hidden in the Cartesian plane, where y will give you the length of the opposite leg:

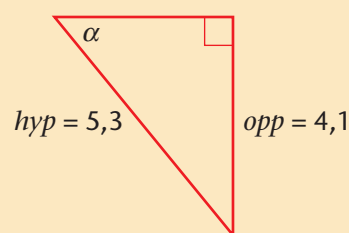
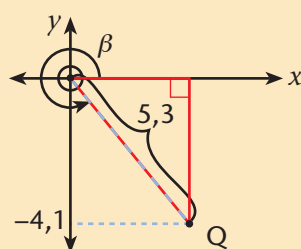

Note: We have enlarged the triangle to make it clearer. It is similar to the one on the left so, all the ratios are the same!

Note: We have obtained the lengths of *hyp* and *opp* from r and y .

Step 3: Determine α

$$\sin \alpha = \frac{4,1}{5,3}$$

$$\alpha = \sin^{-1} \frac{4,1}{5,3}$$

$$= 50,676\ 910\ 82 \dots^\circ$$

$$= 50,7^\circ$$

Step 4: Interpret the value of α to get the value of β :

$$\beta = 360^\circ - \alpha = 360^\circ - 50,7^\circ = 309,3^\circ$$

B. Alternative solution

Step 1: Realise you can also use cosine to get β :

Step 2: Can be done as follows, using the other hidden right-angled triangle:

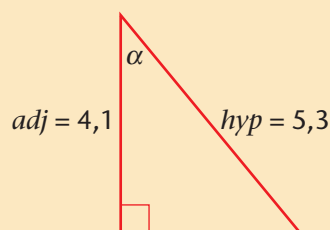
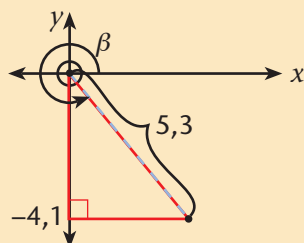

Note: the y value is used to give the length of the adjacent side to β .

Step 3: will involve solving for α using $\cos \alpha = \frac{4,1}{5,3}$. This gives $\alpha = 39,3^\circ$.

Step 4: $\beta = 270^\circ + \alpha = 270^\circ + 39,3^\circ = 309,3^\circ$

Worked example Finding the unknown coordinates

Problem: A point G is 1,48 units from the origin and the line segment between the point and the origin makes an angle of 37° with the positive x -axis. Determine the coordinates of G to two decimal places.

Solution:

Step 1: Make a sketch

Note: The sketch looks believable: 37° is less than 45° , so draw the radial line closer to the x -axis than the y -axis. You should always try to make realistic diagrams where possible – it is a good habit and will make solving problems and checking your solutions easier.

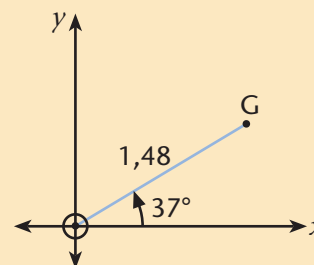

Step 2: Decide which coordinate to calculate first. Let's go for x first. We know the angle θ , we have r , so we can use cosine.

Step 3: Set up an equation and solve it:

$$\frac{x}{1,48} = \cos 37^\circ$$

$$x = 1,48 \cos 37^\circ$$

$$= 1,181\ 980\ 555 \dots$$

$$= 1,18$$

Step 4: Now determine y . There are two ways we can do this. We could use $\sin 37^\circ$ and solve in a similar way as in Step 3. Or we can use the Theorem of Pythagoras. We need a right-angled triangle for that. Identify the triangle in your sketch:

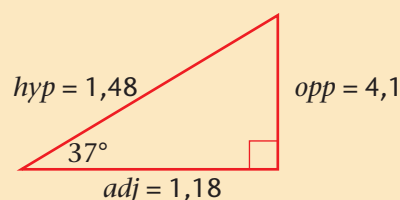
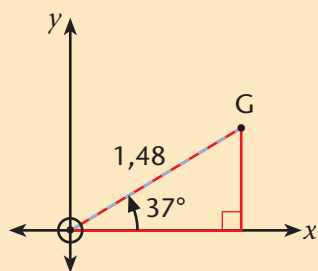

Step 5: Solve for y and state the coordinates of G:

$$opp^2 = (1,48)^2 - (1,18)^2$$

$$opp = \sqrt{(1,48)^2 - (1,18)^2}$$

$$= 0,893\ 308\ 457\ 4\dots$$

$$= 0,89$$

So, $y = 0,89$ and the coordinates of G are $(1,18; 0,89)$.

Useful knowledge: For any point in the Cartesian plane there are four numbers: x and y , the Cartesian coordinates, and r and θ . Each trigonometric function relates three quantities; θ , and any two of x , y , and r . So, if you have any two of x , y , r , or θ then you can calculate the other two.

In Exercise 35 that follows, in the problems (a) – (h), two of the four variables are given in each question and you must determine the other two.

Exercise Finding angles, coordinates, and radial distances

35 Solve for the unknown values in the following (lengths and Cartesian coordinates to two decimal places, and angles to one decimal place where necessary):

(a)

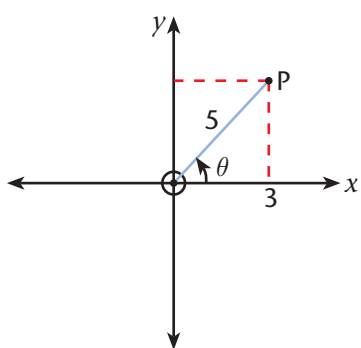

(b)

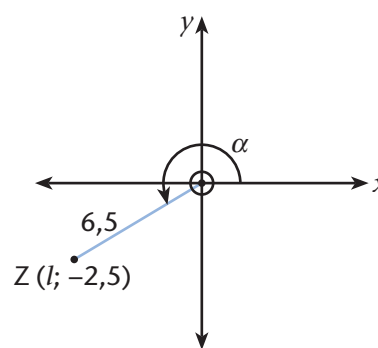

(c)

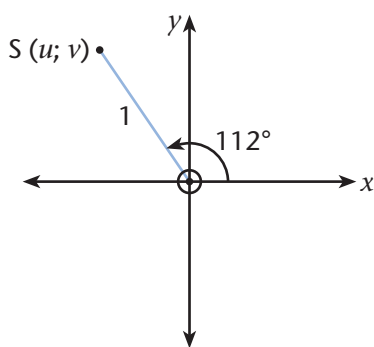

(d)

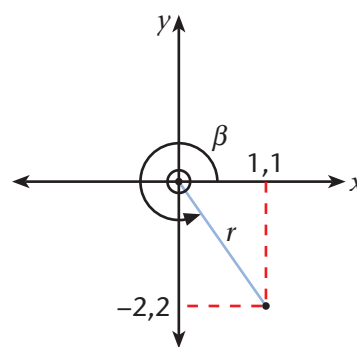

(d)

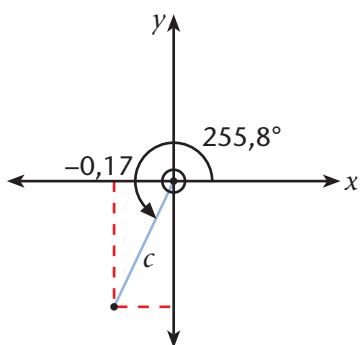

(e)

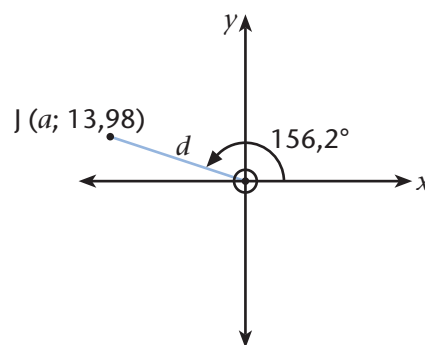

(g) Point $D(e; f)$ is 10 units from the origin at an angle of 325° .

(h) Point $F(3; 5,20)$ is p units from the origin at an angle α .

The next two are a little more challenging. Try them and see how far you can get!

(i) point $W(a; f)$ is 2 units from the origin at an angle $\theta \in (90^\circ; 360^\circ)$, such that $\tan \theta = 1,2$

(j) point $C(m; e)$ is 5 units from the origin at an angle β , such that $\sin \beta = 0,6$ and $\cos \beta = -0,8$

Example A different kind of problem on the same theme

Problem: Determine the values of $\cos \theta$ and $\tan \theta$, if $\sin \theta = \frac{3}{5}$ and $90^\circ \leq \theta \leq 360^\circ$.

Solution: No point or length is given, only one ratio and a domain for θ .

Step1: Determine which quadrant θ corresponds to.

We are told two important things:

that $90^\circ \leq \theta \leq 360^\circ$, involving Q2, Q3, and Q4, and

that $\sin \theta$ is positive, which involves Q1 and Q2 (where y is positive).

We can visualise this using diagrams:

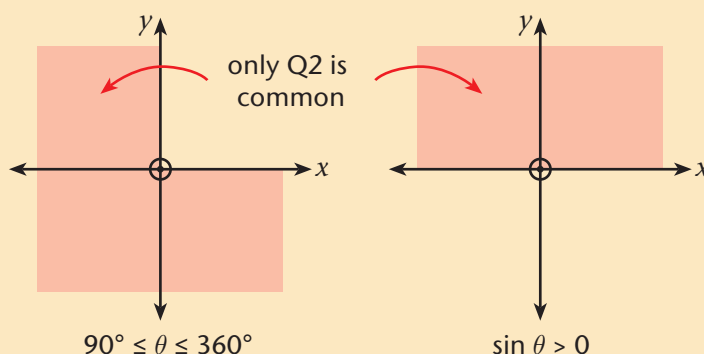

So, we can see that we must be in Q2 (it is the only quadrant that sticks to both requirements).

Step 2: Represent the information on a Cartesian diagram:

We need a way to show the information in the ratio $\frac{y}{r} = \frac{3}{5}$. Since the actual size of our diagram makes no difference, we can simply let $y = +3$ and $r = 5$ (the easiest choice).

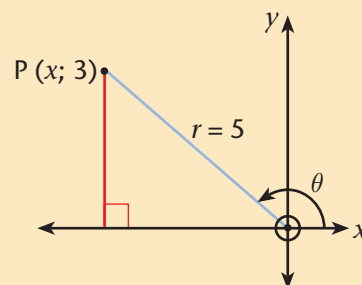

Note: We could just as well have made $y = 6$ and $r = 10$, or $y = 1,5$ and $r = 2,5$, or $y = 0,6$ and $r = 1$... It really doesn't matter because the trigonometric functions output ratios.

Step 3: You have a choice now: either calculate x and then $\cos \theta$ and $\tan \theta$, or calculate θ and then $\cos \theta$ and $\tan \theta$. In both cases, we will need to identify a right-angled triangle in the situation:

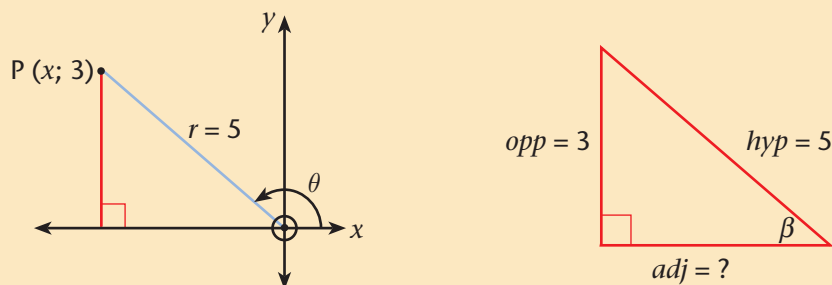

Approach 1: First calculate x and then determine $\cos \theta$ and $\tan \theta$.

Do this by identifying a right-angled triangle and using the Pythagorean Theorem to determine x (as we have done before):

$$adj = \sqrt{5^2 - 3^2} = 4$$

So $x = -4$ (because it is on the negative x -axis.) Therefore:

$$\cos \theta = \frac{x}{r} = \frac{-4}{5} = -\frac{4}{5} \text{ and } \tan \theta = \frac{y}{x} = \frac{3}{-4} = -\frac{3}{4}$$

We have left the solutions in rational form. We have not used the value of θ at all here. We can calculate it if we wish, but it was not asked for, so we won't.

Approach 2: First calculate β and then determine $\cos \theta$ and $\tan \theta$.

Do this by identifying a right-angled triangle (as we have done above already) where opp corresponds to y and using $\sin \theta = \frac{3}{5}$ to calculate β :

In our right-angled triangle:

$$\sin \beta = \frac{opp}{hyp} = \frac{3}{5}$$

$$\beta = \sin^{-1}\left(\frac{3}{5}\right)$$

$$= 36,869\,897\,65 \dots^\circ$$

$$= 36,9^\circ$$

$$\text{So, } \theta = 180^\circ - \beta = 180^\circ - 36,9^\circ = 143,1^\circ.$$

$$\text{Therefore, } \cos \theta = \cos 143,1^\circ = -0,799\,684\,585 \approx -0,80$$

$$\text{and } \tan \theta = \tan 143,1^\circ = -0,750\,821\,238 \dots \approx -0,75$$

Exercise

36 Answer the values of the following *without* calculating the value of the unknown angle.

Where necessary, use sketches of the Cartesian plane to show how you determine the quadrant or axis you need to use, as was done in the example.

Also sketch a Cartesian system for the calculations you do, showing the angle, radial distance, and point with coordinates.

Give your answers in rational form where possible.

- (a) Given that $\operatorname{cosec} \alpha = -1,4$; $90^\circ \leq \alpha \leq 270^\circ$; determine the value of $\sin \alpha$, $\cos \alpha$, and $\tan \alpha$.
- (b) Determine $\cos \beta$ and $\cot \beta$ if it is known that $\sin \beta = 0$ and $\sec \beta < 0$.
- (c) The angle θ is obtuse with $\tan \theta = -\frac{5}{2}$. Determine $\operatorname{cosec} \theta$, $\sec \theta$, and $\cot \theta$.
- (d) Find the values of $\sin \theta$ and $\cot \theta$ if $\cos \theta = \frac{5}{13}$ and $90^\circ \leq \theta \leq 360^\circ$.
- (e) If $\sin \beta < 0$, $\cos \beta > 0$, and $\tan \beta = -0,5$ determine $\sin \beta + \cos \beta$.
- (f) Given that $3 \tan A - 17 = 0$ and that $A \in (0^\circ; 90^\circ)$, determine the values of $\sin A$, $\cos A$, $2 \sin A - \cos A$, and $3 \cot A \cdot \sin A$.
- (g) $\frac{5}{3} \sin \beta - 1 = \frac{1}{3}$ and $90^\circ \leq \beta \leq 360^\circ$. Use this to determine the values of:
 $\tan \beta$, $\frac{\sin \beta}{\cos \beta}$, $\sin \beta \cdot \cos \beta$, and $\frac{1}{1 + \operatorname{cosec} \beta}$.
- (h) It is known that $\tan \theta = 1$ and $180^\circ \leq \theta \leq 360^\circ$. Determine the value of $\sin \theta$, $\cos \theta$,
and $\frac{\sec \theta}{\operatorname{cosec} \theta}$.

6.9 Solving equations involving trigonometric functions for angles between 0° and 90°

Exercise Getting to know the trigonometric functions a little better

37 Use your calculator to solve the following equations. The angles are mostly acute, as you have seen so far, but some are 0° or 90° , which you have not seen yet.

Represent the equation with a right-angled triangle (only when it is possible). When it is possible to draw a triangle, it does not matter what lengths you choose *so long as the ratios work out correctly*.

For example, for (a) it is impossible to draw a triangle.

For example, for (b) we have $opp \div hyp = 0,2$,

so you can let $opp = 0,2$ and $hyp = 1$,

or you can let $opp = 2$ and $hyp = 10$, or $opp = 1$ and $hyp = 5$ etc.

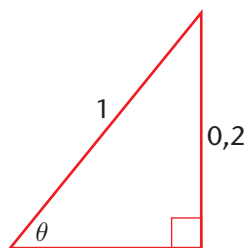

or

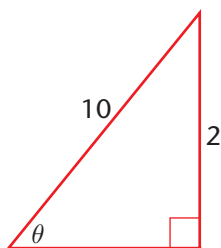

or

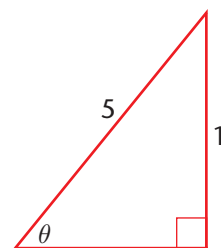

etc...

(a) $\sin x = 0$

(b) $\sin x = 0,2$

(c) $\sin x = 0,4$

(d) $\sin x = 0,8$

(e) $\sin x = 1$

(f) $\sin x = 1,2$

(g) $\cos \alpha = 0$

(h) $\cos \alpha = 0,5$

(i) $\cos \alpha = 1$

(j) $\cos \alpha = 1,01$

(k) $\tan \theta = 0$

(l) $\tan \theta = \frac{1}{3}$

(m) $\tan \theta = \frac{2}{3}$

(n) $\tan \theta = 1$

(o) $\tan \theta = \frac{4}{3}$

(p) Why does (f) cause problems on your calculator? Why does (j) also cause problems? (Hint: The reasons are the same. Second **Hint**: what side of a right-angled triangle is always the longest? Third **Hint**: Why can $opp \div hyp$ never be bigger than 1? What about $adj \div hyp$?)

(q) Refer to (o) now. Unlike sine and cosine, tangent has no problems when the ratio is greater than 1. Are you clear why this is so?

(r) Can you interpret the input and output in (k) as a pitch?

Properties for trigonometric functions in right-angled triangles

$$-1 < \sin \theta < 1 \quad -1 < \cos \theta < 1 \quad \tan \theta \in \mathbb{R}$$

sine and cosine are not defined for outputs greater than 1, but tangent is.

Equations requiring some algebra

Worked example

Problem: Solve for p : $\sin 38^\circ = \frac{13}{11 + 2p}$ correct to three decimal places.

Solution: First make $11 + 2p$ the subject of the equation and then p :

$$\sin 38^\circ = \frac{13}{11 + 2p}$$

$$11 + 2p = \frac{13}{\sin 38^\circ}$$

$$2p = \frac{13}{\sin 38^\circ} - 11$$

$$p = \frac{\left(\frac{13}{\sin 38^\circ} - 11\right)}{2}$$

$$= 5,057\,750\,096 \dots$$

$$= 5,058$$

Note: This is not a proper trigonometric equation because the unknown, p , is not in the input expression of a trigonometric function. Solving this is the same as solving $0,616 = \frac{13}{11 + 2p}$.

Worked example

Problem: Solve for β , correct to 1 decimal place, if $7,08 - 2,35 \tan(\beta - 24,2^\circ) = 1,47$.

$\beta - 24,2^\circ$ lies between 0° and 90° .

Solution: First, make $\tan(\beta - 24,2^\circ)$ the subject and then solve for β :

$$7,08 - 2,35 \tan(\beta - 24,2^\circ) = 1,47$$

$$2,35 \tan(\beta - 24,2^\circ) = 7,08 - 1,47$$

$$\tan(\beta - 24,2^\circ) = \frac{5,61}{2,35}$$

$$\beta - 24,2^\circ = \tan^{-1}\left(\frac{5,61}{2,35}\right)$$

$$= 67,3^\circ$$

$$\beta = 43,1^\circ$$

Note: This is a true trigonometric equation. The unknown is part of the input expression of \tan .

Note: Here we are assuming that the expression $\beta - 24,2^\circ$ has values *between* 0° and 90° . This is because we have only defined the trigonometric functions in right-angled triangles so far and the non- 90° angles in a right-angled triangle are always acute. This is being totally honest with ourselves. Actually, we will see that it can have any real value.

Exercise

38 Solve the following equations, correct to the nearest tenth of a degree. Assume the input expressions for the trigonometric functions are all in the range 0° to 90° :

(a) $\tan x = 7,5$

(b) $\tan(x + 20^\circ) = 7,5$

(c) $2 \sin \alpha = 1$

(d) $2 \sin(\alpha - 15^\circ) = 1$

(e) $\tan \frac{\beta}{3} = \sin 50^\circ$

(f) $\frac{1}{2} \cos 2\alpha - 0,4 = 0$

(g) $1 = 3\frac{1}{5} - 3\sin 2q$

(h) $4 - 3 \cos(80^\circ - 2\beta) = 2$

(i) $\cos 45^\circ + 1 = \frac{2 - \gamma \tan 45^\circ}{3}$

(j) $\frac{1}{\sin(45^\circ - \theta)} = 7$

(k) $3 \cos 2b + 5 = 9 \cos 2b$

(l) $1,72 - \frac{\tan 72,4^\circ + \beta}{0,6} = 0,36$

(m) $\frac{1}{\tan x} - 3 = -2\frac{1}{2}$

(n) $1 + \frac{12,5}{1 + 3 \sin 5\alpha} = 7,25$

(o) $x - 1 = x \sin 30^\circ$

(p) $\frac{\tan 2(\theta - 30^\circ)}{2} = \frac{3}{5}$

(q) Which of the equations above are not true trigonometric equations?

6.10 Solving problems involving right-angled triangles

Angles of elevation and depression

Angle of elevation

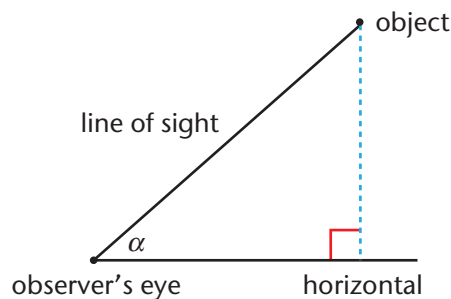

Angle of depression

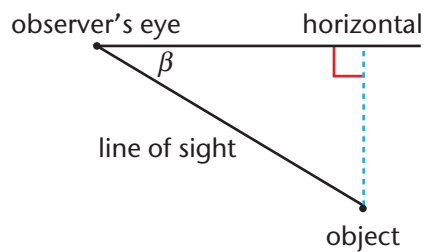

Note: elevation is also called inclination and depression is also called declination.

Angle of depression

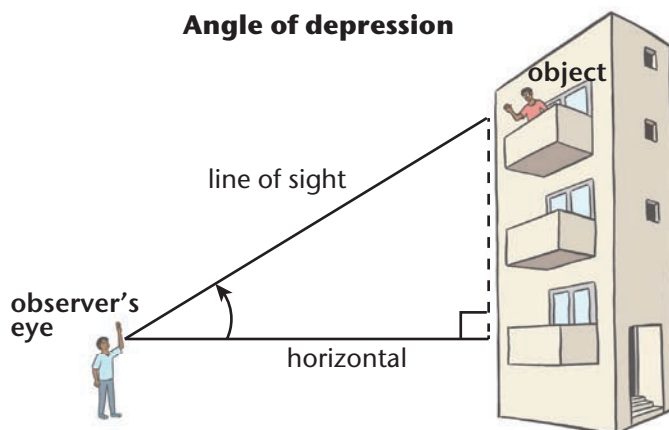

Angle of depression

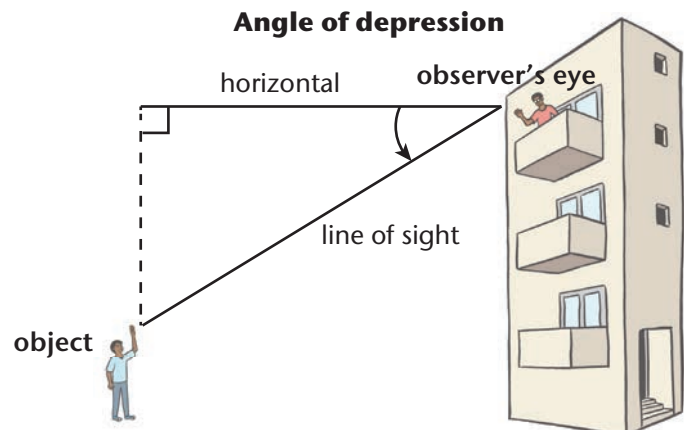

Worked example

Problem: A person is standing 50 m away from a tall tree. The ground is totally level between him and the tree. He measures the angle of inclination of the top of the tree to be 24° . His eyes are 1,5 m above the ground when he makes the angle measurement.

How tall is the tree?

Solution:

Step 1: Realize that the problem has a right-angled triangle in it.

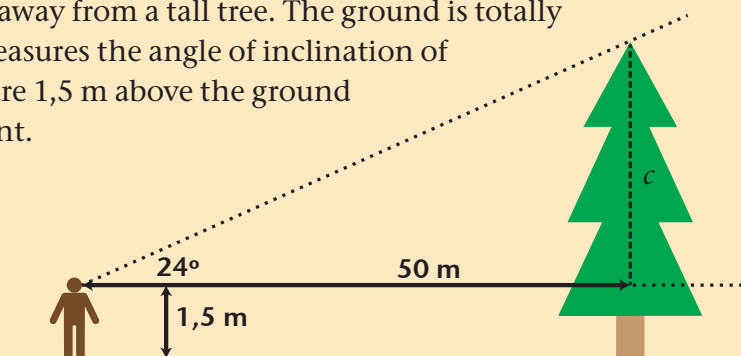

Step 2: Identify the trigonometric function that links what you know with what you want to calculate. Here, we have the angle of 24° and the adjacent side of 50 m. We want to calculate the opposite side c . So we must use tangent.

Step 3: Apply the trigonometry you have identified and solve for c :

$$\begin{aligned}\frac{c}{50} &= \tan 24^\circ \\ c &= 50 \tan 24^\circ \\ &= 22,3 \text{ m}\end{aligned}$$

Step 4: Have we finished? No! This is not the height of the tree. Let's finish:

$$\text{height} = 22,3 \text{ m} + 1,5 \text{ m} = 23,8 \text{ m}$$

Exercises

- 39 A developer decides to measure the height of the office block in which she works. She measures the length of the shadow cast by the building to be 7 m. At the same time, she also measures the length of her own shadow to be 20 cm.

We can draw the triangles to represent the two situations (not to scale):

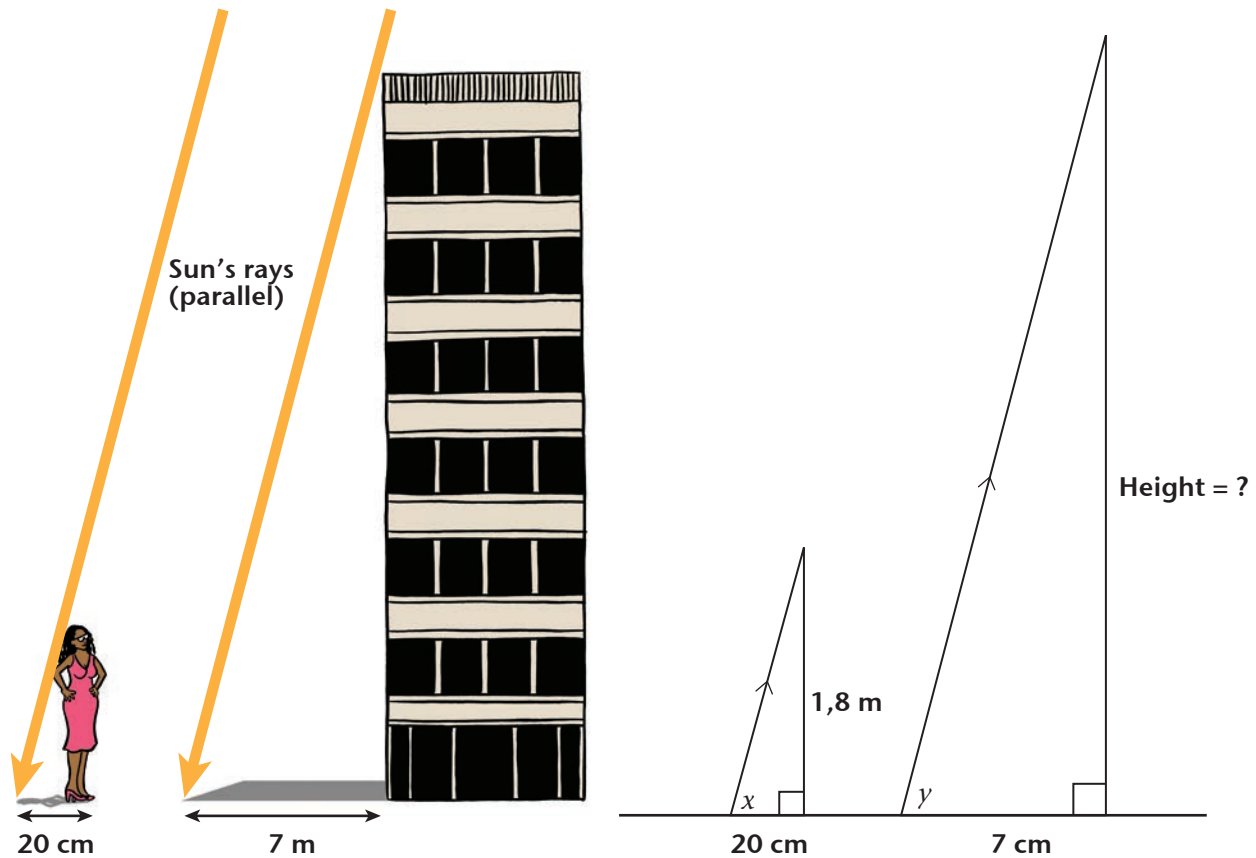

She is 1,8 m tall, as shown in the small triangle.

- What can you say about the angles x and y ? Give a reason for your answer.
- Calculate the height of the building. Do you *have* to use the trigonometric functions to determine the height?
- Calculate the angle of elevation of the sun. Do you *have* to use trigonometric functions to determine x ?

40 The photo shows part of the gable-end of a house (the fascia board is white):



The bricks are 22,3 cm by 7,1 cm and the pointing is 12 mm wide.

- Using only the above information, give the pitch of the roof in decimal form, rounded to the nearest hundredth.
 - What is the slope of the roof in degrees, rounding to the nearest degree?
 - A practical question: Explain why it is easier to make a roof at any pitch when the gable is wooden, compared to when it is built with bricks. Perhaps make some drawings of different ways to lay the bricks to get different roof pitches.
- 41 Aristarchus of Samos was a mathematician and astronomer who studied and worked in Alexandria, in North Africa, almost 2 300 years ago. He is the first recorded person to try to calculate the distances between the Earth and the Sun, and the Earth and the Moon. He is also one of the very first people to study the relationships between angles and length ratios in right-angled triangles, making him one of the discoverers of trigonometry.

His big insight was that when the Moon appears as a half-moon from the Earth, the line from the Earth to the Moon is perpendicular to the line from the Moon to the Sun:

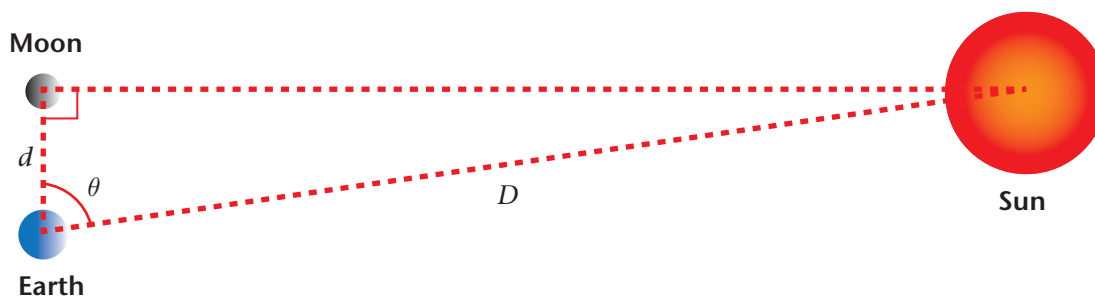

So, the distance between the Earth and the Sun will be the hypotenuse of an imaginary right-angled triangle, with the Moon at the right-angle. Let us represent the Earth-Moon distance with d and the Earth-Sun distance with D .

- Aristarchus measured the angle θ to be 87° . Use this value to calculate ratio $D:d$, rounded to the nearest integer. Interpret what the value of the ratio told him about the two distances.
- Later it was realised that the value of θ that Aristarchus measured was not accurate. The value correct to four significant figures is $89,83^\circ$. Use this to calculate a better value for the ratio $D:d$, rounded to the nearest integer. Interpret what the value of the ratio tells us about the two distances.
- The error in Aristarchus' value for θ is 'just' $2,83^\circ$. This may seem insignificant. Compare the two results you obtained in (a) and (b). What effect does the small error in θ have on the calculated value of $D:d$? Precision and accuracy are very important!

Note:

Trigonometry, as you are learning it now with the functions sine, cosine, and tangent, only emerged later, through the work of Arabic mathematicians – about a thousand years ago. Aristarchus would have probably performed his 'calculation' of the ratio $D:d$ by making a scale drawing of a right-angled triangle with an acute angle of 87° .

Aristarchus did not have an accurate value for either d or D . About a century after Aristarchus died, another astronomer, named Hipparchus of Nicaea, calculated that d is approximately 30 Earth diameters in size. He did this using a complicated calculation first suggested by Aristarchus, along with some very accurate readings of his own. The value of 30 Earth diameters is amazingly close to the modern accepted value.

- Use the modern value of the Earth's diameter, 12 742 km, to calculate the distance between the Earth and the Sun.

- 42 A salvage ship is locating a shipwreck. The salvage ship's sonar indicates that the wreck is at an angle of depression of 28° below the water level. Ocean charts indicate that the average depth of the water near the wreck is 50 m. A diver wearing a pressurised diving suit is lowered into the water directly below the salvage ship. There is a pipe supplying the diver with air from a compressor on the salvage ship.

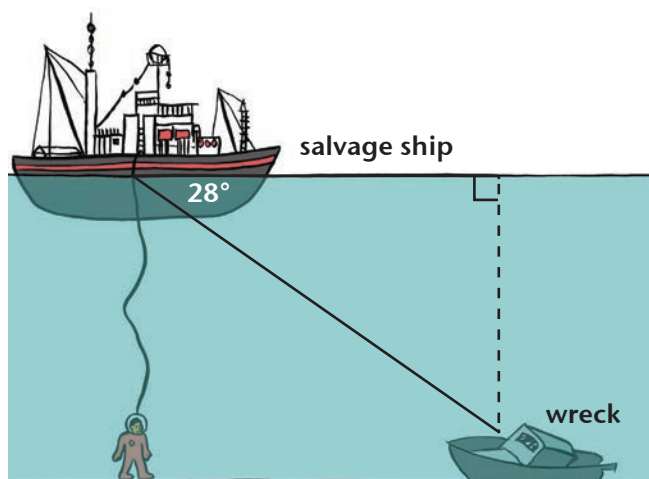

- The air pipe linking the diver to the salvage ship is 110 m long. Can the diver reach the wreck?
- How far will the diver have to walk on the ocean floor to reach the wreck?

- 43 Countersinking depth and chamfer angle: Often in working with wood or metal it is necessary to countersink a screw, rivet, etc. First, the hole for the screw or rivet is drilled. Then the chamfer is countersunk to the required depth.

Six common chamfer angles are shown in cross-section along with two cross-sections of the drilled hole with the countersunk chamfer.

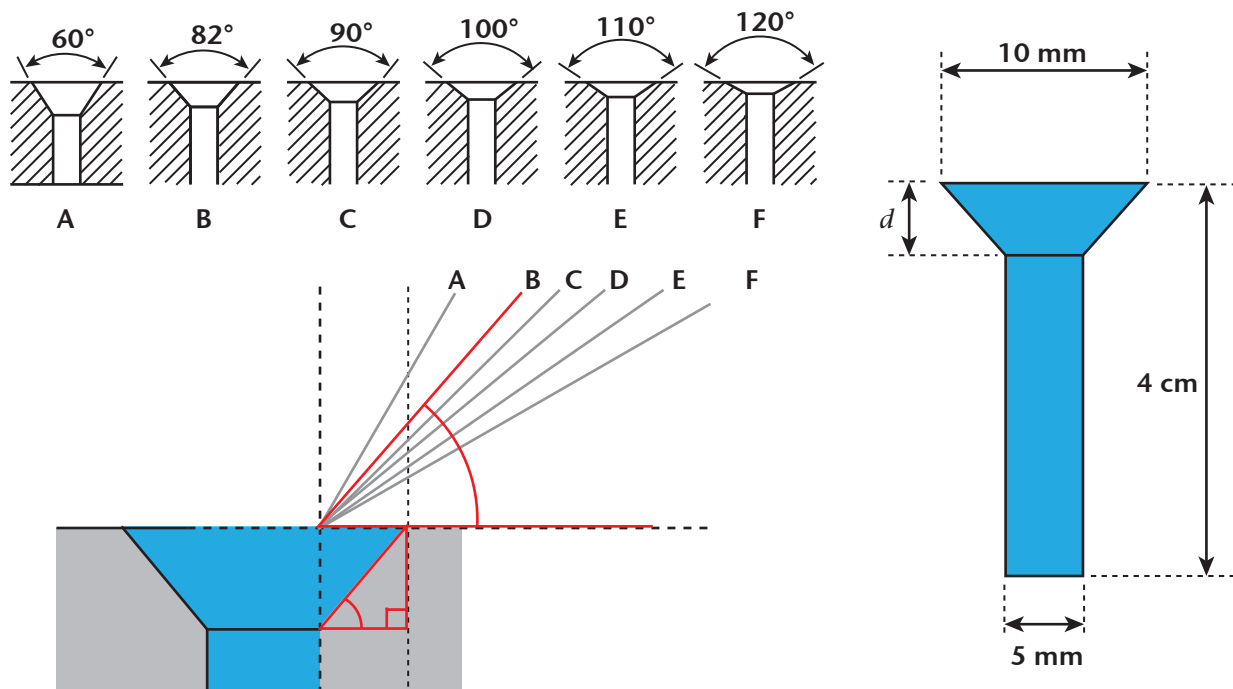

The material to be drilled is 4 cm thick. The drill hole is 5 mm in diameter. The diameter of the countersunk hole is 10 mm. The angle that the countersunk hole makes with the horizontal is θ . The depth of the countersunk hole is d .

Calculate the value of d for each of the six chamfer angles. Organise the six angles and your results in a table.

- 44 You are making roof trusses out of wood for an extension you are building:

The pitch angle of the trusses must be 35° . The length of the lower side of the bottom chord (the horizontal bottom member) is 5 m.

- Calculate the lengths AC and BC. Round off your answer to the nearest cm.
- Are the lengths you calculated, the actual lengths of the king post (the vertical member) and the top chord (the slanted members)?

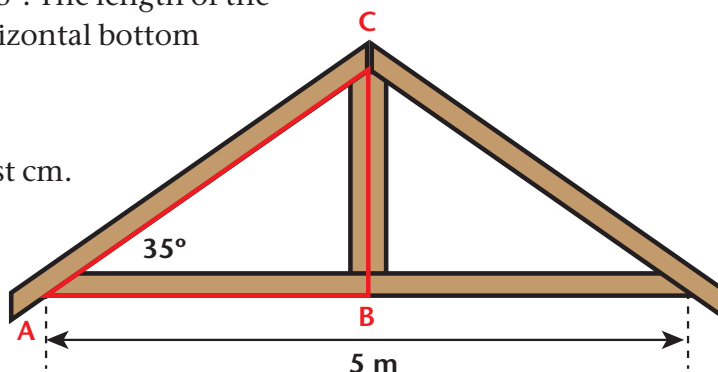

Suppose that the beams used to make the five components of the truss are 10 cm wide.

- (c) What actual length of the beam will be needed to make the king post? NB: this is before it is cut to shape.
- (e) Draw a diagram of the king post showing how you will cut it to the shape as shown in the diagram. At what angle must the two slanted edges at the top be cut?

- 45 A woodworker is designing a sawdust-collection system. It will be attached to a vacuum cleaner. She decides, as part of her design, to make a cyclone dust collector out of sheet metal. It is called a cyclone because the air moves in a spiral inside it; like the weather phenomenon of the same name.

The radius of the upper opening must be 25 cm and the lower opening, 10 cm. The funnel is 75 cm high.

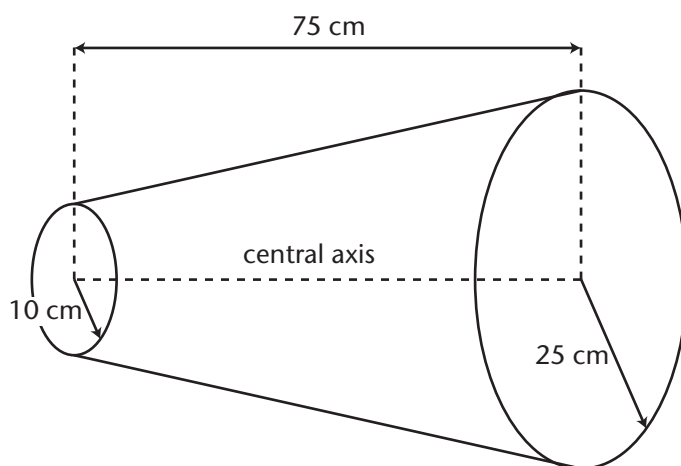

- (a) Draw a cross-section of the collector as seen from the side i.e. a cross-section through the plane of the axis. Fill in the three measurements.
- (b) Calculate the angle where the sides of the funnel come in contact with the central axis. (**Hint:** you must identify a suitable right-angled triangle that includes the angle and length information.)

- 46 Solar panels convert light energy into electrical energy. They work the best when they are tilted so that they are perpendicular to the rays of the sun. The diagram below shows a cross-section through a roof with the solar panel facing directly towards the sun.

Some triangles and angles have been drawn in for you. The roof has a pitch of 20° . The angle of elevation of the sun at mid-day is 42° .

- Show that the angle θ must be 68° .
- The solar panel is 80 cm by 80 cm. Calculate the length l of the support strut to the nearest cm.
- Challenge: Think practically: Do you think that this solar panel will still work properly after a few months? When will it work at its best again?

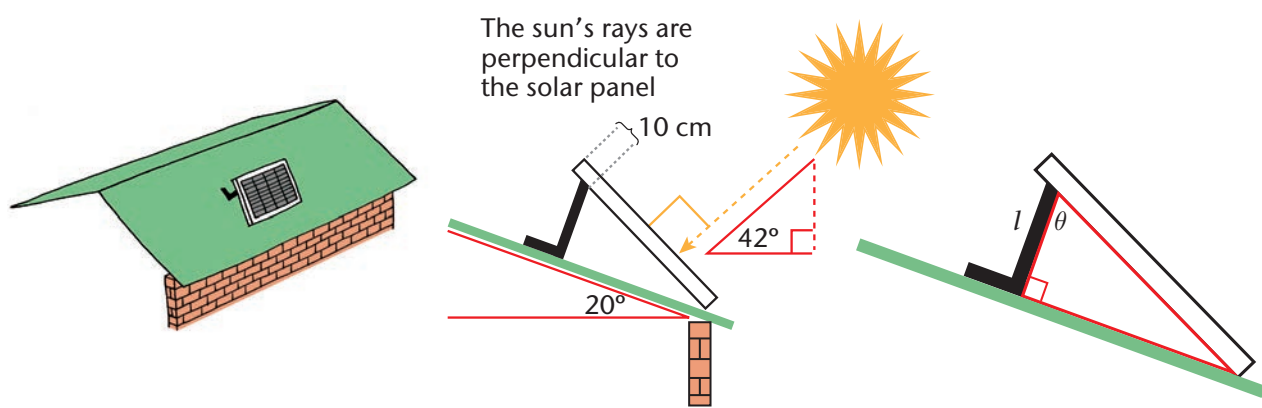

6.11 The graphs of the basic trigonometric functions

Check APPENDIX 1 at the end of the chapter if you need some revision or reminders about plotting (input; output) coordinate pairs of a function and how to read outputs from inputs or inputs from outputs on a graph.

Plotting the value of $\sin \theta$ and $\cos \theta$ against θ : the graphs of the sine and cosine functions

Exercises The input-output graphs for the sine and cosine functions

You will need two sheets of graph paper for the following two questions.

- 47 Plotting outputs of $\sin \theta$ for $0^\circ \leq \theta \leq 360^\circ$.
- Use the TABLE MODE on your calculator to complete an input-output table (or calculate each output one at a time as before) for 25 input angles starting at 0° , ending at 360° with jumps of 15° (round to one decimal place):
 - The table is itself a way of representing a function. You can learn something about the sine function by looking carefully at the values you have calculated. Do you see the pattern in the values? Try to describe it.

(c) Now, represent the output values and input values on a Cartesian grid in the following way:

- Place your sheet of graph paper in 'landscape' position (longest sides horizontal).
- Draw a horizontal axis across the centre of the grid and a vertical axis along the left side; the origin is at the centre of the left side of the grid.
- The horizontal axis will be the θ -axis (i.e. the input axis), and the vertical axis will be the $\sin \theta$ - axis (the output axis).
- Choose a scale (in degrees) for the θ -axis (make this as large as possible – you should have 24 blocks across); choose a vertical scale for $\sin \theta$ from -1 to 1 (again, make it as large as possible – you should have 8 blocks above and below the origin; use 5 to make jumps of 0,2 units).

Your graph paper should look like this:

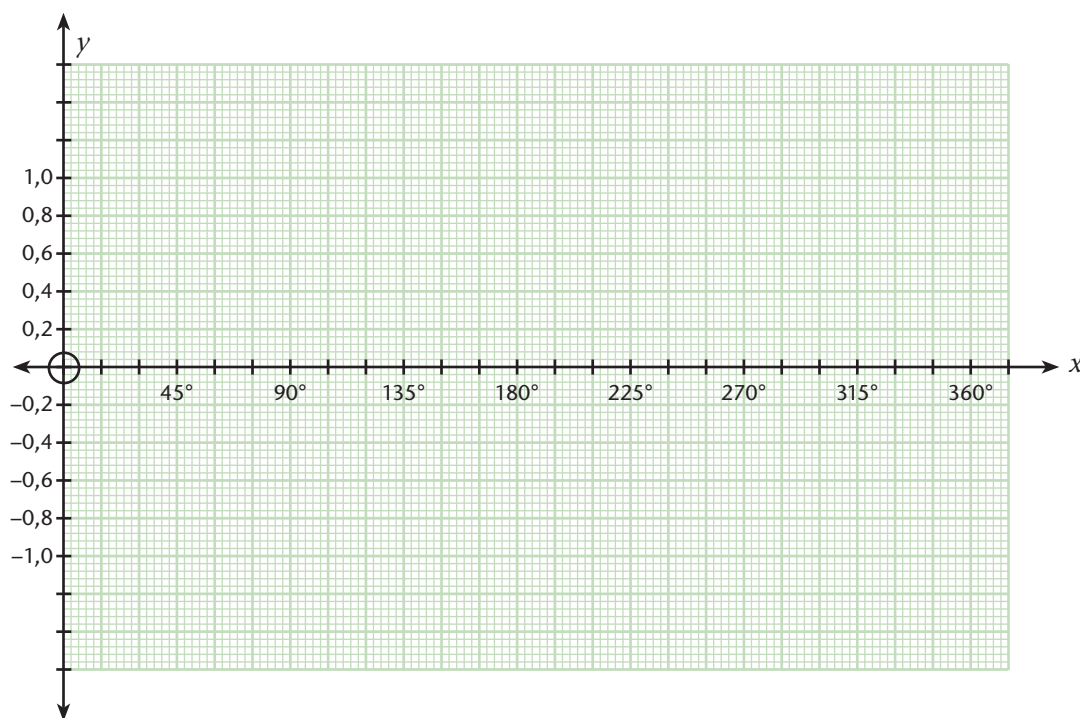

- Now, plot the 25 (θ ; $\sin \theta$) coordinates.
 - With a steady hand, draw a smooth curved line through all 25 coordinates (NB: do not join with straight lines – trigonometric functions do not have straight line functions in them).
- (d) Describe the graph you have drawn.
- How does the shape of the part of the graph between 0° and 180° compare with the part between 180° and 360° ?
 - How does the part between 0° and 90° compare with the part between 90° and 180° ?
 - What else do you see? Describe any other special characteristics of the graph you see.

The following shows some of the points you have plotted. Check that you agree with them. If not, you must go back and check all your points.

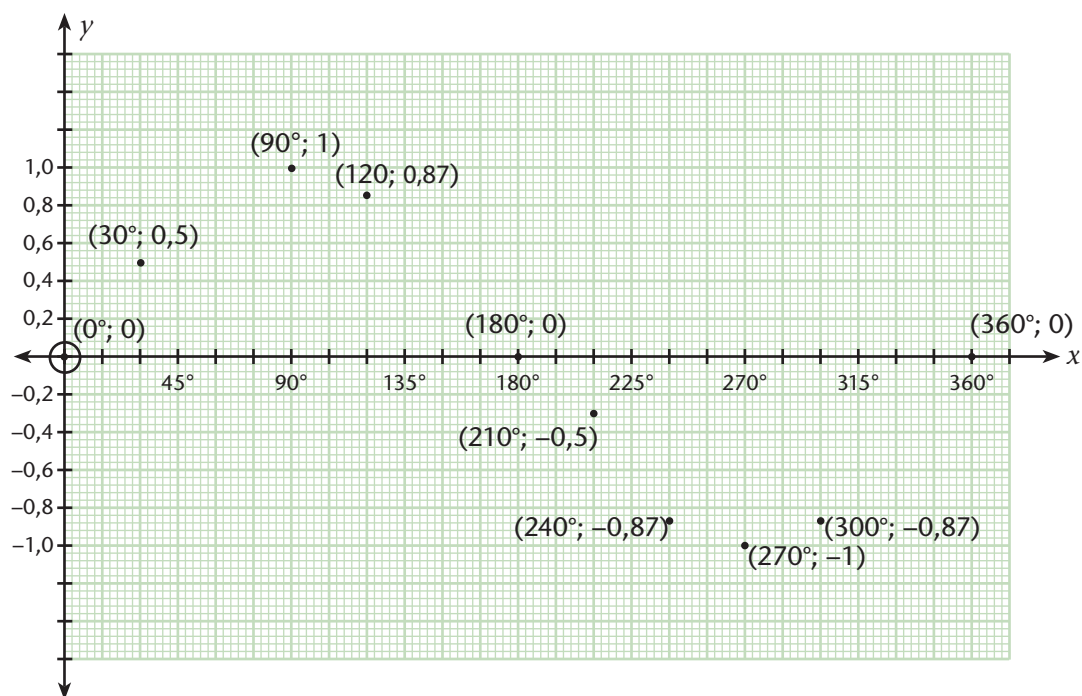

48 Plotting outputs of $\cos \theta$ for $0^\circ \leq \theta \leq 360^\circ$.

Repeat all the steps and answer all the questions from the previous exercise, for the cosine function on the other sheet of graph paper.

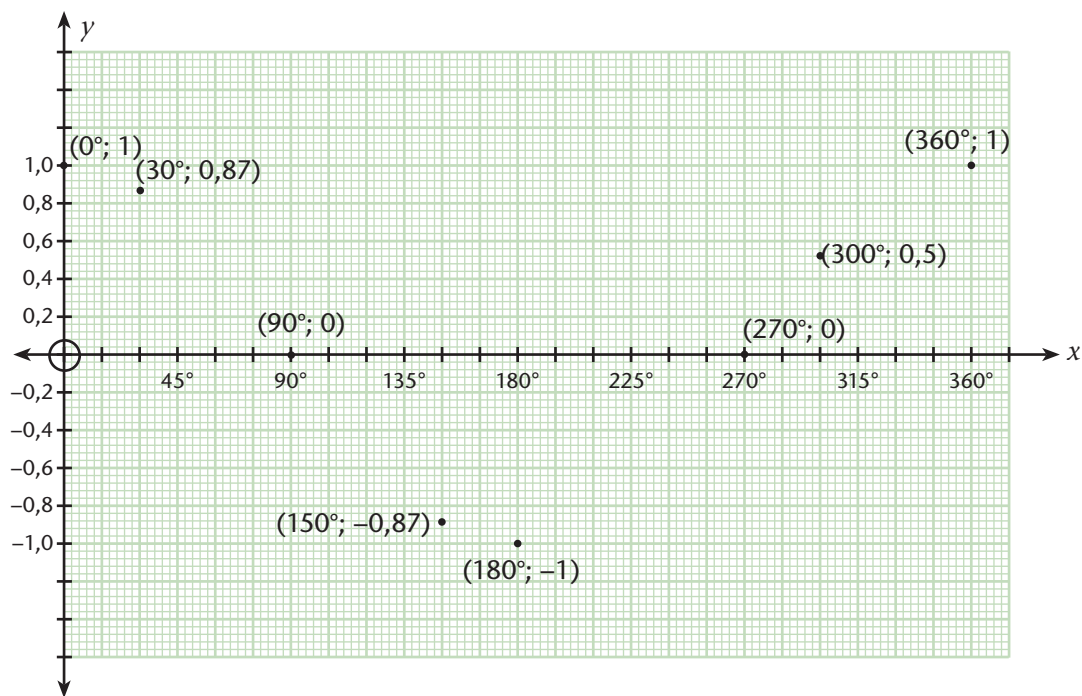

Some of the points you have plotted are shown above for you to check how successfully you have done the task:

Some terminology

Maximum and minimum points on a graph: These are output values on a graph that are bigger than the near-by output values, or smaller.

Turning point: If the graph is smoothly curved near its maximum or minimum points we call them turning points.

Amplitude of a sine or cosine graph: This is the maximum distance from the input axis to the graph. For sine and cosine this is 1. Amplitude is a positive quantity.

The graphs of the three basic trigonometric functions

The functions, $y = \sin \theta$, $y = \cos \theta$, and $y = \tan \theta$, can be graphed in the Cartesian plane by plotting input-output coordinates $(\theta; y)$.

- The horizontal axis is also called the x -axis or input axis.
- The vertical axis is also called the y -axis or output axis.

Properties of the graph of $y = \sin \theta$

- sinusoidal (wave-like shape)
- has turning points at $(90^\circ; 1)$ and at $(270^\circ; -1)$
- turning points correspond to amplitude of 1 unit
- has positive y -values for $0^\circ < \theta < 180^\circ$, and negative values for $180^\circ < \theta < 360^\circ$
- increases from 0° to 90° , decreases from 90° to 270° and then increases from 270° to 360°
- has intercepts at $(0^\circ; 0)$, at $(180^\circ; 0)$, and at $(360^\circ; 0)$

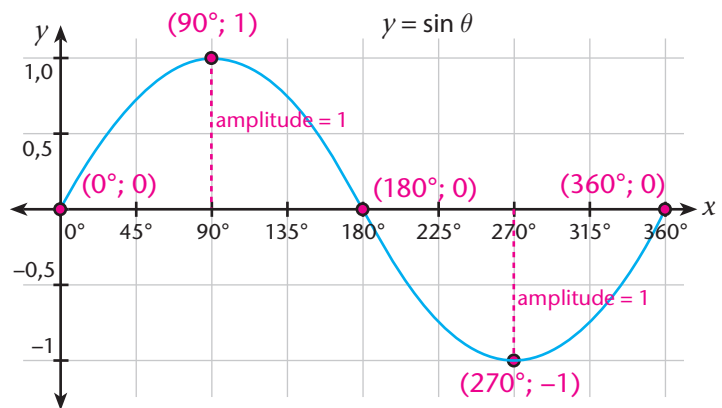

Properties of the graph of $y = \cos \theta$

- sinusoidal (wave-like shape)
- has turning points at $(0^\circ; 1)$, at $(180^\circ; -1)$ and at $(360^\circ; 1)$
- turning points correspond to amplitude of 1 unit
- has positive y -values for $0^\circ < \theta < 90^\circ$ and $270^\circ < \theta < 360^\circ$, and negative values for $90^\circ < \theta < 270^\circ$
- decreases from 0° to 180° and increases from 180° to 360°
- has intercepts at $(0^\circ; 1)$, at $(90^\circ; 0)$, and at $(270^\circ; 0)$

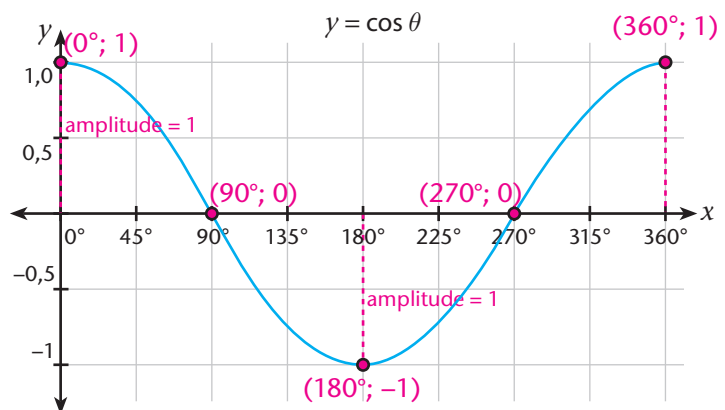

Comparing the graphs of the sine and cosine functions

You have probably realised that the sine and cosine functions are the same shape – they are! They are actually **congruent** to each other.

Exercise

49 The graphs of $\sin \theta$ and $\cos \theta$ have been drawn together here:

- Which is the sine graph and which is the cosine graph?
- The cosine graph has a maximum of +1 at 0° . Is there another maximum? Does it have a minimum, if so, at which input angle? What is the minimum value? Do you see what you expect from the properties of the cosine function?
- Investigate the maximum and minimum values of the sine function. Do you see what you expect from the properties of the sine function?
- Are the maximum and minimum points on the two graphs also turning points? Explain why. Give the coordinates of the turning points.
- Imagine chopping the two graphs into four parts each, at 90° , 180° and 270°

Which parts of the two graphs are identical (congruent) to each other? (**Hint:** for example the part of the sine graph between 0° and 90° is congruent to the part of the cosine graph between 270° and 360° – you do the others).

Important: the sine and cosine graphs are actually identical, just shifted along the θ -axis. The shape of the graphs is called **sinusoidal**. This is the classic wave shape that is used in so many practical situations e.g. to describe water waves, sound waves, EM waves, alternating current, etc. You will develop a much better understanding of why the two graphs are actually congruent in Grade 11 and 12.

Letter symbol conventions: abusing and confusing x , y , and θ

What is written here may confuse you. It is confusing. You may have to come back here and read and re-read this to start making sense of it. That's just fine.

We will often write the three functions as follows:

$$y = \sin \theta$$

$$y = \cos \theta$$

$$y = \tan \theta$$

y represents the output *ratio* here, while θ represents the input angle.

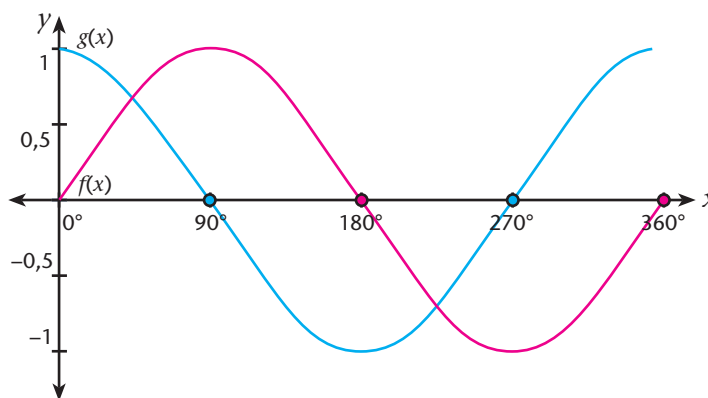

This also makes sense when we look at the Cartesian definition of sine:

$$\frac{y}{r} = \sin \theta \quad \text{if we keep } r = 1 \text{ then } y = \sin \theta \text{ makes perfect sense.}$$

It also makes sense for tangent since,

$$\frac{y}{x} = \tan \theta \quad \text{means } y = \tan \theta \text{ if we keep } x = 1$$

It makes less sense for cosine because the Cartesian definition involves x , not y :

$$\frac{x}{r} = \cos \theta \quad \text{means } x = \cos \theta \text{ if } r = 1$$

Even worse, we often represent the input angles with x instead of θ :

$$y = \sin x \qquad y = \cos x \qquad y = \tan x$$

Have we replaced x by y now?
Yes, but we don't mean the same y as in $y = r \sin \theta$. Writing $y = r \cos \theta$, where y takes the role of x , is mathematically acceptable but confusing.

How can we make sense of this confusion?

We will be pragmatic.

For the Cartesian definitions of sine, cosine, and tangent:

- x and y will be the coordinates of the point $P(x; y)$ that is a distance r from the origin, at angle θ (which represents the angle input).
- **Note:** here we are *not* making y the output of input x ; the two axes are *not* input-output number lines. The $(x; y)$ coordinates are just positions of points in this situation.

Pragmatic is a really good word to add to your vocabulary. It means to simplify things just enough so we can move on. Being pragmatic means not getting all tied up in details that will slow down your progress. Successful students know when to make pragmatic choices.

For the function inputs and outputs of sine, cosine, and tangent:

- Input angles may be represented by θ or x , and output ratios are represented by y or the function symbol, e.g. $f(\theta)$ if the input is represented by θ , or $f(x)$ if the input is represented by x . On this point, look ahead four pages to the paragraph on notation.
- **Note:** When we plot the graph of the function, the coordinate pair $(\theta; y)$, or $(x; y)$, represents (*input; output*) pairs. The two axes are input-output number lines. The coordinate is *not* the position of a point at a certain angle to the positive x -axis in this situation.

Stretching, squashing, flipping graphs

Exercise To get you thinking

50 Consider the graph of the function $y = \sin \theta$. The value of $\sin 41^\circ$ is 0,656. We can plot the input-output coordinate $(\theta; y) = (41^\circ; 0,656)$:

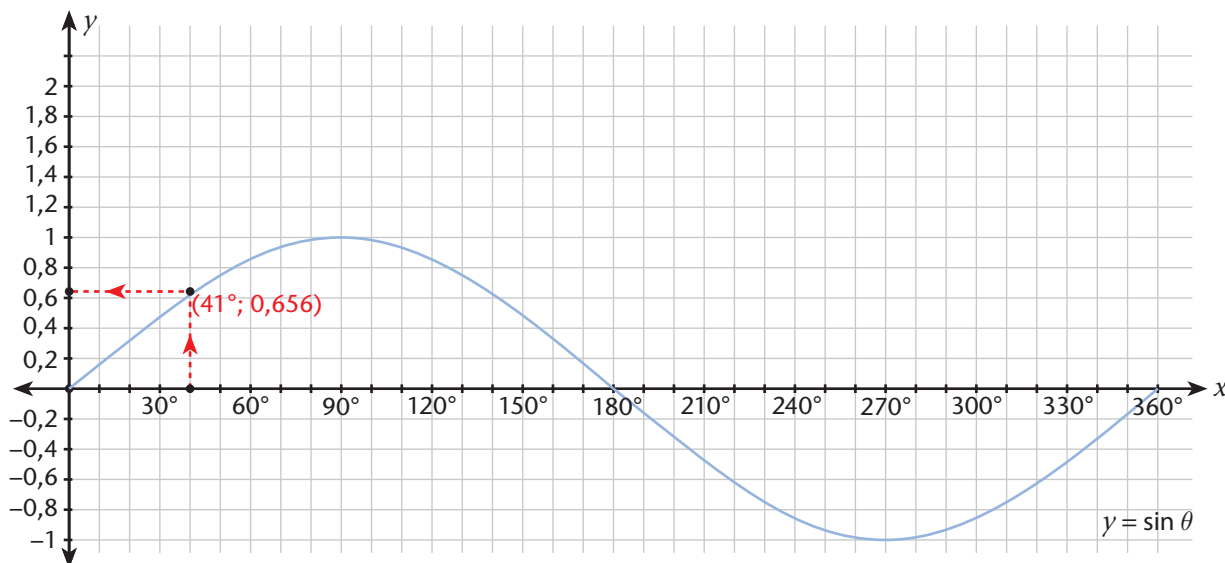

Follow the arrow direction along the dashed line from input 41° to output 0,656.

- (a) We can write a different function down based on sine: $y = 2\sin \theta$, where θ is the input and the output is $2 \times \sin \theta$.
- Calculate the output of this new function for the input 41° . Write the input-output as a coordinate pair.
 - Do not plot the point. Describe where you would plot it. Where will the point be compared to the point $(41^\circ; 0,656)$ from the first function?
- (b) We can write another function down: $y = \frac{1}{4}\sin \theta$.
- Calculate its output at 41° and give the input-output coordinate pair.
 - Describe where this point will be compared to the point $(41^\circ; 0,656)$.
- (c) Here's a fourth function: $y = -\sin \theta$. Answer the same questions as before.
- (d) Copy and complete the following table (the functions have been given labels f, g etc.)

θ	f $y = \sin \theta$	g $y = 2 \sin \theta$	h $y = \frac{1}{4} \sin \theta$	k $y = -\sin \theta$
41°				
90°				
180°				
203°				

What have we learned?

Compare the function g with f (the g 's outputs are in red):

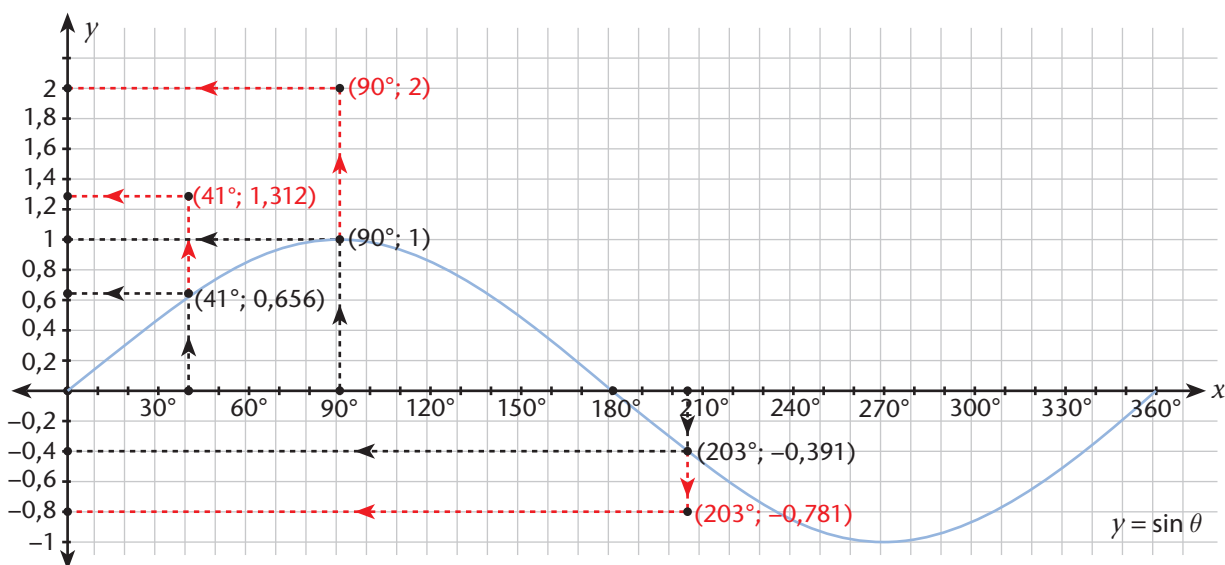

- For any input angle we choose the output of g that is twice the output of f because of the factor of 2 (the coefficient), so
- for every θ -coordinate the y -coordinate of the graph of g is twice as far from the θ axis as for f .

Comparing the function h with f :

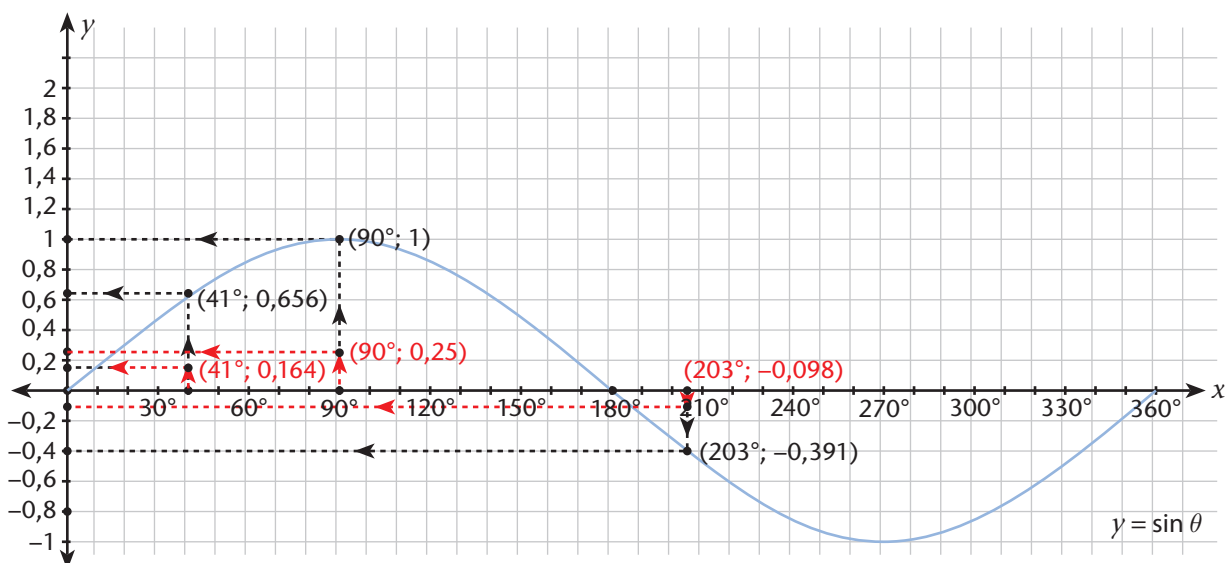

- For any input angle we choose the output of g that is a quarter (one-fourth) of the output of f because of the coefficient $\frac{1}{4}$, so
- for every θ -coordinate the y -coordinate of the graph of g is one quarter of the distance from the θ axis as for f .

Comparing the function k with f :

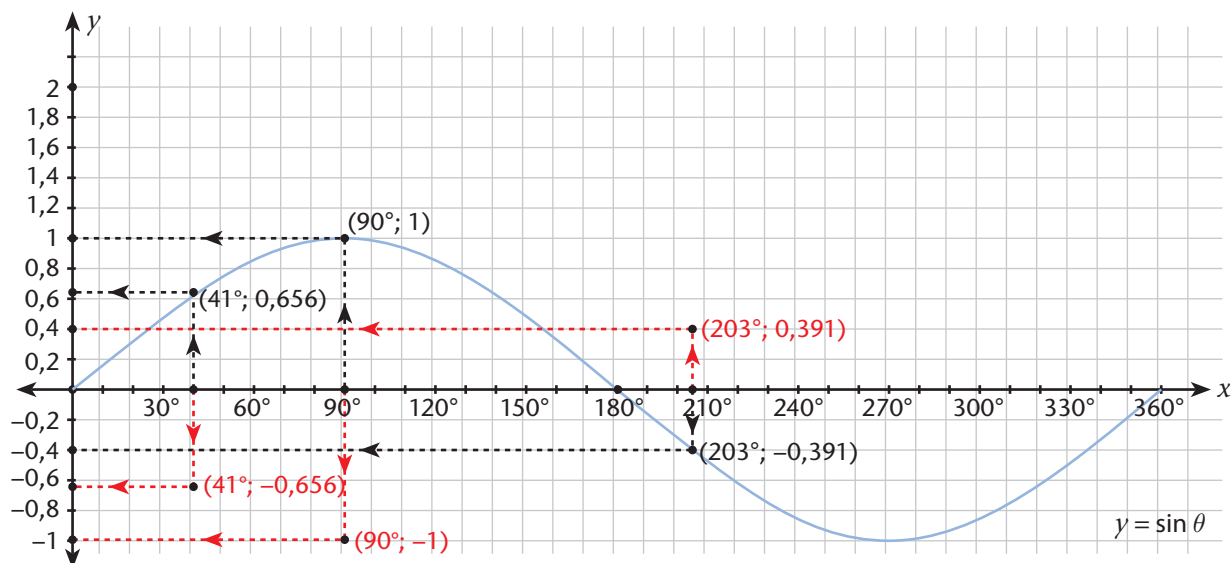

- For any input angle we choose the output of g that is the negative of the output of f because of the coefficient -1 , so
- for every θ -coordinate the y -coordinate of the graph of g is the same distance from the θ -axis as for f , just on the opposite side of the θ -axis.

If we plot many more input-output coordinates for the four functions, we can show all four graphs on one Cartesian plane to compare their shapes:

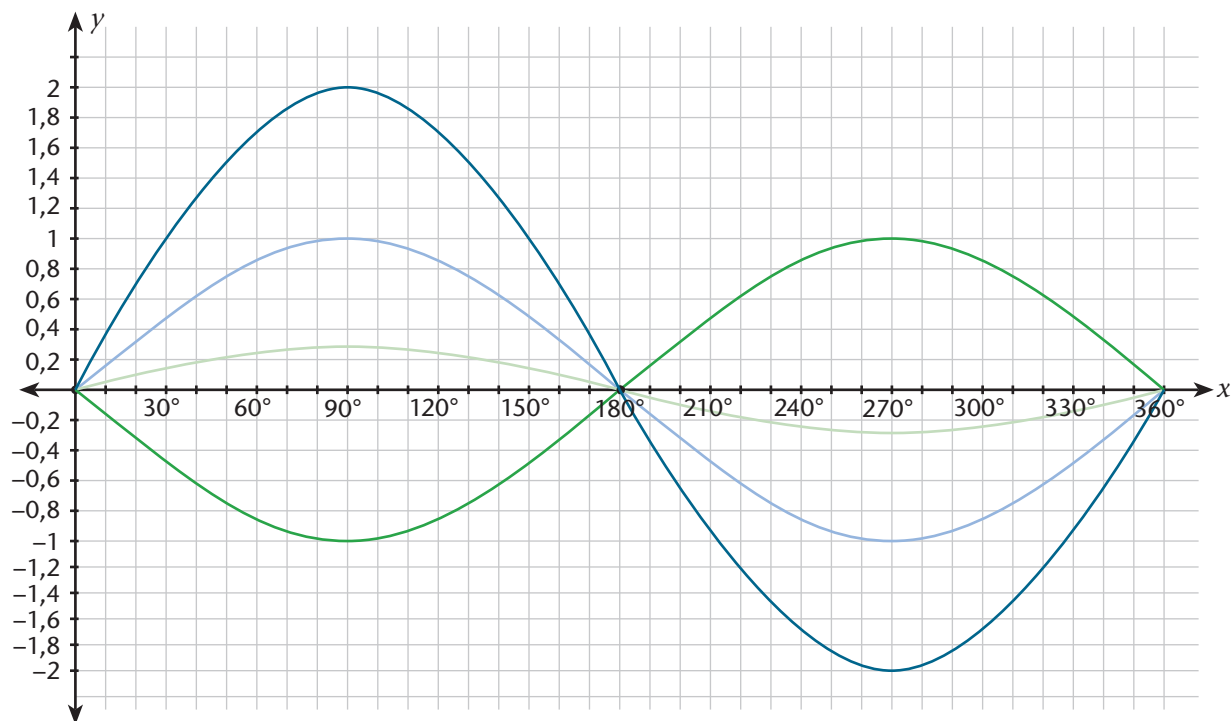

Exercise

51 Identify f , g , h , and k in the above diagram. Make sure you understand how the graphs relate to each other through their coefficients.

Notation: a way of labelling different functions

We have four functions in the above exercise. All of them involve the function $\sin \theta$, which can be confusing.

It is helpful to give them separate function names so we can refer to them quickly.

We usually label/name functions with a single letter. f , g , and h are the most commonly used, but you can use any letter.

Here is some **conventional notation** you need to know about that you will be using from now on:

We called $y = \frac{1}{4} \sin \theta$ the function h in the previous exercise.

- We say that $y = \frac{1}{4} \sin \theta$ is the function h (its name or label).
- We can write the outputs of h as $h(\theta)$; while h is the name of the function, $h(\theta)$ represents the function process (the process that h uses to calculate outputs) and the function outputs (the output variable).
- We can write a particular output as $h(41^\circ) = 0,164$.
We read this as follows: The value of the function h at 41° is 0,164.
- We can write the equation of the function as $h(\theta) = \frac{1}{4} \sin \theta$. We read this as: The value of the function h at θ is calculated using the expression $\frac{1}{4} \sin \theta$.
- When we plot the graph of h we can write $y = h(\theta)$ to show that the output of h at θ is the y -coordinate of the ordered pair $(\theta; y)$.
- We can write the variable input-output ordered pair as $(\theta; y)$, or as $(\theta; h(\theta))$, or even as $(\theta; \frac{1}{4} \sin \theta)$.

Now writing

$h(x) = \frac{1}{4} \sin x$ may make more sense to you because the

x , like the θ , is just a place holder for input values.

Saying that:

'the value of the function h at θ is calculated using the expression $\frac{1}{4} \sin \theta$ ', is the same as saying:

'the value of the function h at x is calculated using the expression $\frac{1}{4} \sin x$.'

We can make $\theta = 41^\circ$ in the first case or $x = 41^\circ$ in the

second, but $h(41^\circ) = \frac{1}{4} \sin 41^\circ = 0,164$ all the same.

Plotting the value of $\tan \theta$ against θ : the graph of the tangent function

The graph of the tangent function is very interesting and very strange. There are some important new concepts that we will encounter with it.

Some advice: Keep track of three important things and you will find things simpler to understand:

- how the graph curves
- where it cuts the axes (the intercepts)
- where it is undefined

The really strange stuff about the tangent graph has to do with the last point!

Look at your calculator manual, or ask a friend, to see how to access a very useful tool on your calculator, called TABLE MODE. It is easy to use and will make your work much, much less in this section.

Exercise You will need graph paper here

52 Plotting outputs of $\tan \theta$ for some inputs between 0° and 360° .

- (a) Use the TABLE MODE on your calculator to complete the following table, or calculate each output one at a time as before, for all 25 input angles.

Round off the outputs to two decimal places

θ	$\tan \theta$
0°	
15°	0,27
330°	-0,58
345°	
360°	

Note: Your output column will say 'ERROR' for inputs of 90° and 270° . You should not be surprised by this! If you are, go back to Exercise 26(b) and make some sense of this.

- (b) The table is itself a way of representing a function. You can learn something about the tangent function by looking carefully at the values you have calculated. Do you see the pattern(s) in the values? Try to describe it (them) (**Hint:** compare the outputs in each of the four quadrants with each other.)

(c) Now, represent the output values and input values on a Cartesian grid in the following way:

- Place your graph paper in 'landscape' position (longest sides horizontal).
- Draw a horizontal axis across the centre of the grid and a vertical axis along the left side; the origin is at the centre of the left side of the grid.
- The horizontal axis will be the θ -axis (i.e. the input axis), and the vertical axis will be the $\tan \theta$ -axis (the output axis).
- Choose a scale (in degrees) for the θ -axis; you should have 24 blocks across, so each major gridline is a jump of 15° .
- Choose a vertical scale for $\tan \theta$; you should have 8 blocks above and below the origin; use every second major gridline to mark off a jump of 1.
- Draw dashed, vertical lines through 90° and through 270° on the θ -axis and label them $\theta = 90^\circ$ and $\theta = 270^\circ$; the meaning of these lines will become clear soon (you can already guess if you are awake).

Your graph paper should look like this now:

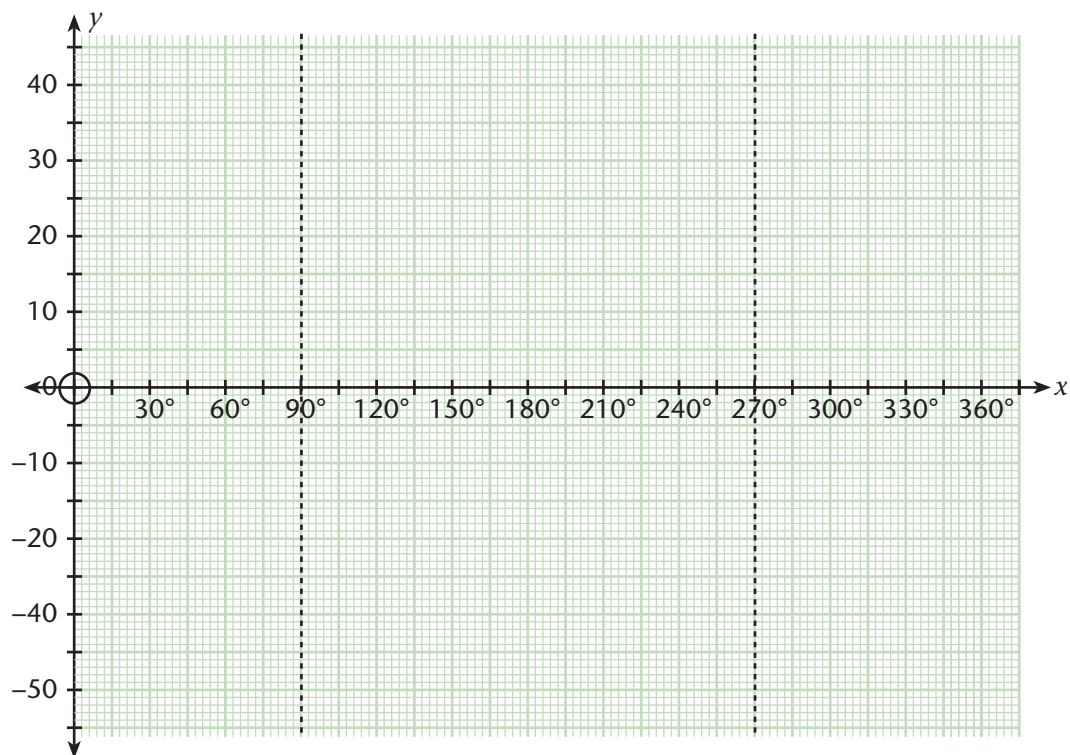

- Plot the twenty five (θ ; $\tan \theta$) coordinates.
- With a steady hand, draw a smooth curved line through the first 6 points, stopping before you reach the first dashed line at 90° .
- Draw a smooth curve connecting the 11 points between 90° and 270° .
- Draw a smooth curve through the last 6 points that lie beyond the second dashed line at 270° .

(d) Describe the graph you have drawn.

- How does the shape of the graph between 0° and 90° compare with the piece between 180° and 270° ?
- How does the part between 90° and 180° compare with the part between 270° and 360° ?
- What else do you see? Describe any other special characteristics/patterns you see in the graph.

(e) Have a look back at the properties of the tangent function. Try to see these properties in the graph.

(f) Have a look a little further back. Can you see any of the characteristics of pitch ratio and pitch angle in the graph (the part between 0° and 90°)?

The points you plotted should look something like this (check that you agree):

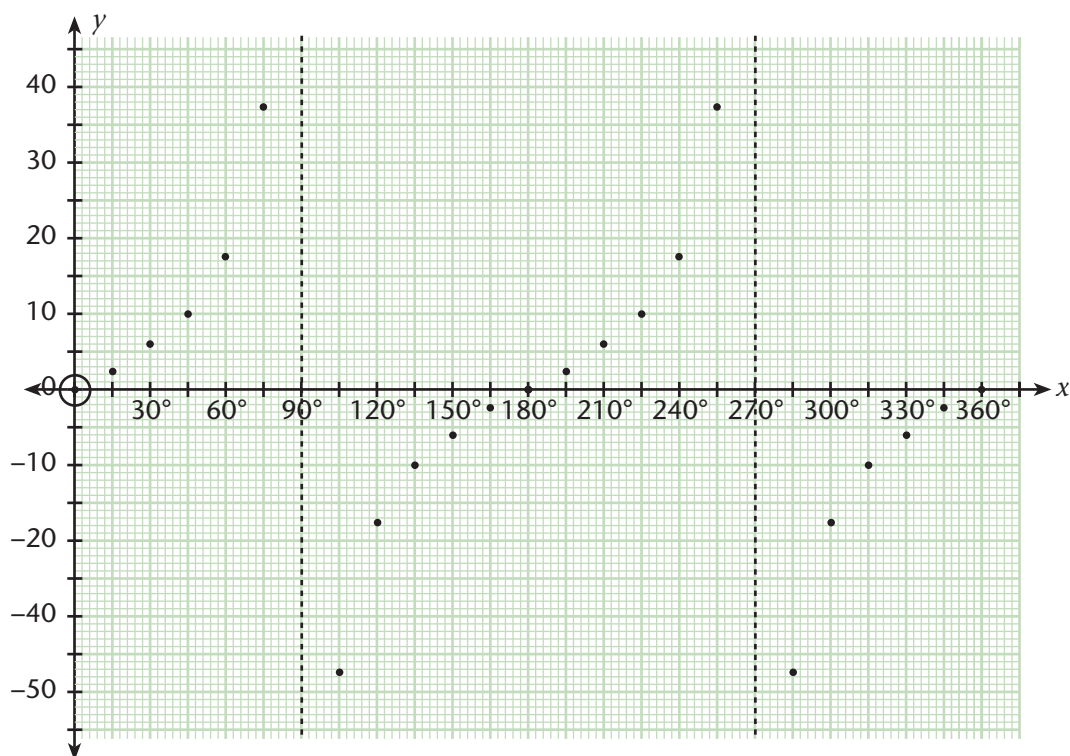

Once you draw a smooth curve passing through all the points your graph should look something like this (no straight bits!):

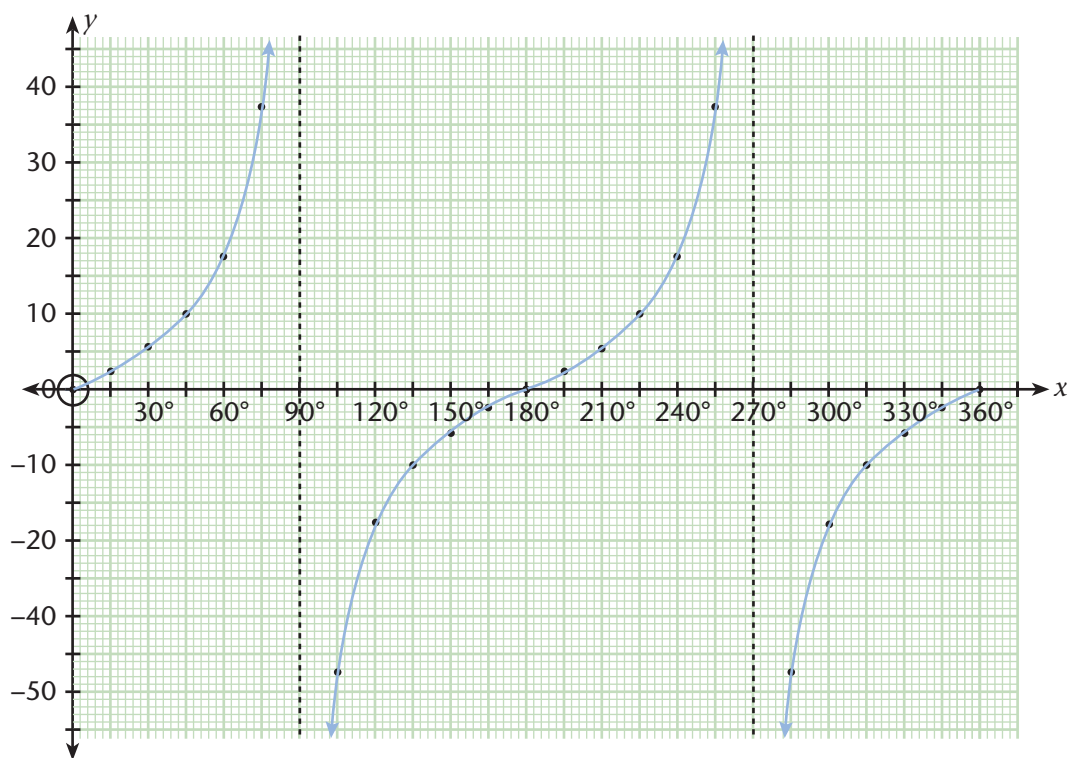

What is going on near $\theta = 90^\circ$ and $\theta = 270^\circ$? We need to investigate.

Exercises Investigating outputs of tangent near 90° and 270°

- 53 What happens for input angles that are close to the forbidden angles of 90° and 270° ? Set up your own investigation. Maybe you can work with others so that each of you focuses on different angle inputs. (**Hint:** If you work in a group of four it will be best. Two of you investigate what happens as the input angle gets closer to 90° from below 90° , and above it. The other two do the same for 270° .)

- 54 Let us look up some values and check these against the calculator's values. Look at the following graph carefully. The output axis has been scaled up by a factor of 10 to allow us to represent more output values of tangent.

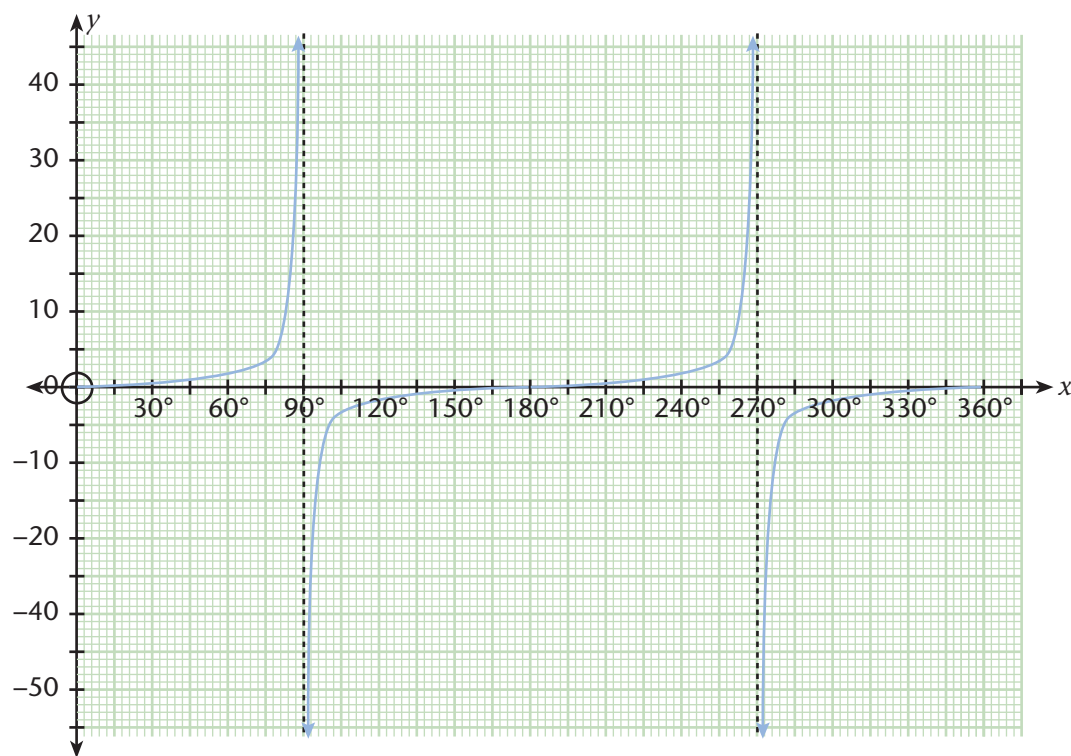

- Look at the interval where $75^\circ \leq \theta < 90^\circ$. Determine the inputs that give the following outputs: 5; 10; 20; 40.
- Calculate the outputs for the following input angles: $89,5^\circ$; $90,5^\circ$; $269,5^\circ$; $270,5^\circ$. What can you say based on this?
- Do you think that $\tan \theta$ can have a maximum value? A minimum value?
- Calculate the outputs for the following angles: $89,6^\circ$; $89,7^\circ$; $89,8^\circ$; $89,9^\circ$.
- Do you still stand by your answer in (c)?
- Choose an angle that is bigger than $89,9^\circ$ but smaller than 90° . Determine the tangent of your angle. Choose another angle that is closer to 90° than the one you just used and calculate the tangent of it. If you continue this, what do you think you will find? Do you still agree with your answer in (c)?

We need a new term to describe what we are finding here:

Asymptote: (a-symp-tote): This is a line that the graph of a function gets closer and closer to without touching as you draw the graph (and the line) longer and longer.

The distance between the asymptote and the graph of the function gets smaller and smaller without ever becoming zero. Another way of describing this is to say that the graph seems to become parallel to the line but they never actually do become parallel.

Exercise Checking the definition

55 The asymptotes of the tangent function correspond to the angles of undefined outputs. Check that the definition given here describes what you observed in the previous exercise.

Some conventions about asymptotes:

- We should always show the asymptotes of a graph *even though they are not part of the graph*. (Why aren't they part of the graph?)
- We usually draw them with a dashed line, or a line that is much finer than the line of the graph.
- Write down the equation of each asymptote next to it (a good habit), e.g. on our tangent graph, the one at 90° is a straight line with equation $\theta = 90^\circ$. The other one has equation $\theta = 270^\circ$.

Note: The asymptotes we will deal with are always straight lines, and always parallel to the axes. However, in general they don't have to be. They could be the curves of other functions

Some terminology to describe what we have seen

Dilation and Contraction: A dilation is when something stretches. A contraction is when something is squashed.

The effect of the coefficient of 2 in g , compared to f , is a dilation of factor 2 from the θ -axis.

The effect of the coefficient of $\frac{1}{4}$ in h , compared to f , is a contraction towards the θ -axis by a factor of $\frac{1}{4}$.

Reflection: When something is flipped over. We say that it is reflected around a line.

The effect of the coefficient of -1 on the graph of k , compared to the graph of f , is to reflect it around the θ -axis.

Properties of the graph of $y = \tan \theta$

- has asymptotes at $\theta = 90^\circ$ and at $\theta = 270^\circ$
- always increasing from left to right
- has intercepts at $(0^\circ; 0)$, at $(180^\circ; 0)$ and at $(360^\circ; 0)$

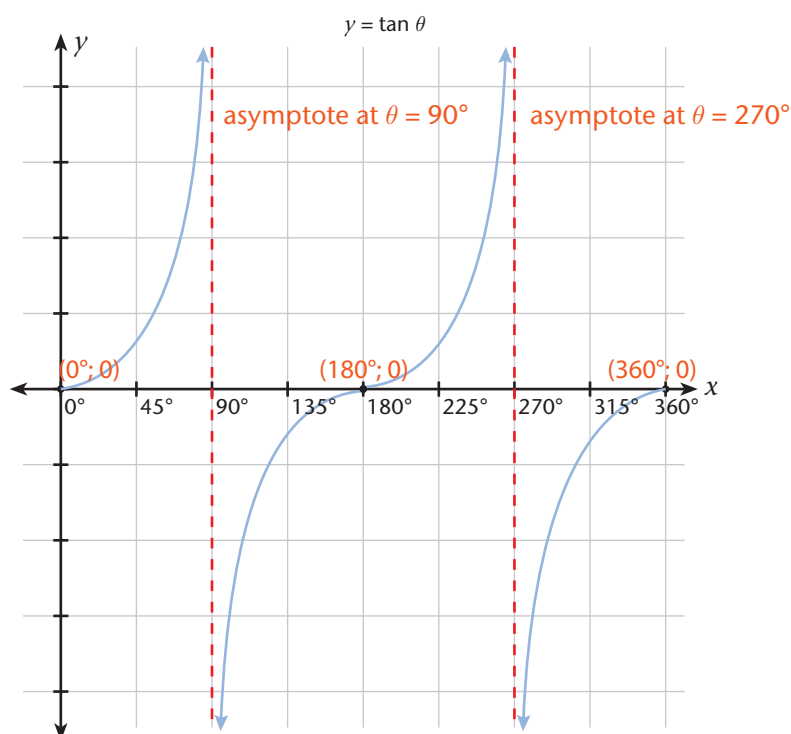

Exercises

- 56 For which values of a will $q(\theta) = a \sin \theta$ be a
- dilation of $p(\theta) = \sin \theta$ from the θ -axis?
 - contraction of $p(\theta) = \sin \theta$ from the θ -axis?
 - reflection of $p(\theta) = \sin \theta$ around the θ -axis?
- 57 Plot the graphs of $f(x) = \cos x$, and $g(x) = -\cos x$ on the same system of axes by plotting nine coordinates for each function on scaled graph paper.
- Draw up a table with input angles x running from 0° to 360° with jumps of 45° .
 - Plot these on graph paper using an input scale of 45° for every three large blocks and an output scale of 1 to 5 blocks. Label your axes.
 - When you draw smooth lines through the points, use different colours for the two functions, or make one a solid line and the other dotted.
 - Label your axes x and y , and clearly indicate which graph is of f and which is of g .
- Give the coordinates of all the intercepts.
 - Give the coordinates of all the turning points.

- (c) What is the amplitude of the two functions? Do they have the same amplitude?
- (d) For which angle inputs are the two graphs separated by the greatest distance? What is this separation distance?
- (e) Give the coordinates of the points where the graphs of the two functions intersect (cut) each other.
- (f) What are the domain and range of g ?

58 The functions u and v are defined as $u(\theta) = 0,4 \tan \theta$ and $v(\theta) = 1,2 \tan \theta$.

- (a) Draw up an input-output table (three columns: θ , $u(\theta)$, and $v(\theta)$) for the two functions over the domain $0^\circ \leq \theta \leq 180^\circ$, $\theta \neq 90^\circ$, using 30° jumps.
- (b) Write down the following sentences in your exercise book and select the correct terms and supply the missing factors in the statements:
 - (i) ' u is a contraction/dilation of v by a factor of _____.'
 - (ii) ' v is a contraction/dilation of u by a factor of _____.'
 - (iii) 'The only points on the graph of u and v that are not influenced by the coefficients are the _____.'
- (c) Plot the $(\theta; y)$ coordinates on a properly scaled piece of graph paper using the input scale of 1 major block to 10° and a vertical scale of one output unit to every four blocks. Label the axes.
 Draw in the asymptote and write its equation.
 Draw a smooth curve through the points you have plotted.
- (d) Give the ranges of the two functions. How do they compare with the range of $w(\theta) = \tan \theta$?

59 Optional question (extension):

- (a) An object attached to the end of a spring bounces up and down according to an equation of the form $d = a \cos \beta t$. The motion of the object at its highest position of 5 m above its rest point, bounces down to its lowest position of 5 m below its rest point, and then bounces back to its highest position in a total of 4 seconds. Write an equation that represents this motion.
- (b) Graph your equation from $t = 0$ seconds to $t = 4$ seconds.



Exercises Optional

60 This question is not difficult but requires a clear head. You should definitely try it because it links important ideas of the Cartesian definition of trigonometric functions with their Cartesian input-output graphs. This is also a practical situation where dilation/contraction occurs.

A situation of two Ferris wheels: suppose one Ferris wheel has a radius of 6 m and another, a radius of 12 m:

Ferris wheel

A fairground ride consisting of a giant vertical revolving wheel with passenger cars suspended on its outer edge.

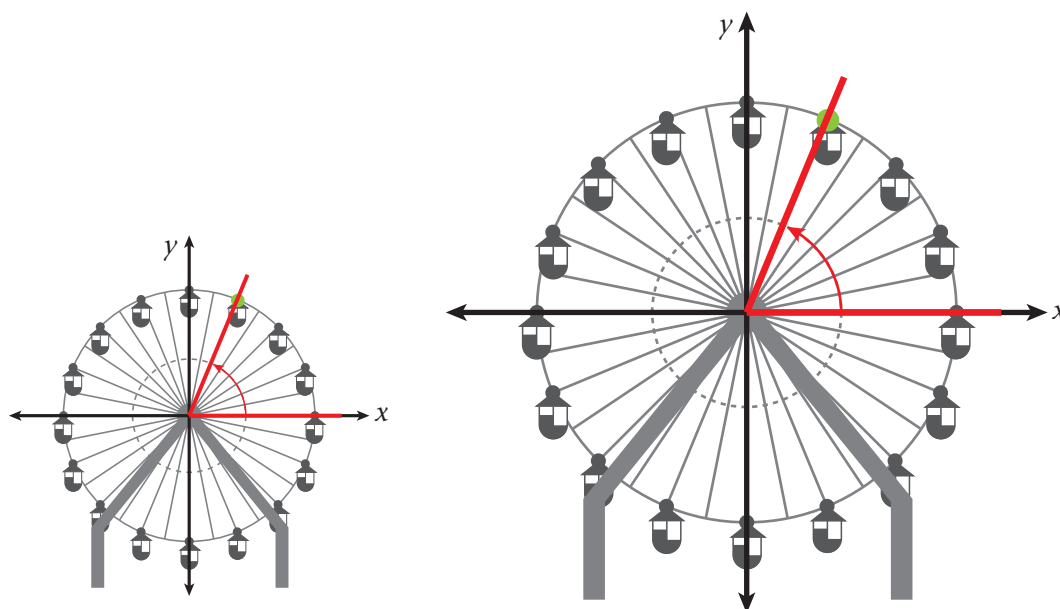

The two diagrams show the cradles at the same angle, $\theta = 67,5^\circ$ to the positive x -axis.

- Calculate the x -coordinate of the green point for the smaller wheel.
- Use your solution in (a) and the ratio of the radii of the two wheels to calculate the x -coordinate of the connecting axle for the bigger wheel.
- Plot the graph of $h(\theta) = 6 \cos \theta$ and $H(\theta) = 12 \cos \theta$ on the same scaled piece of graph paper (you choose the best scale).
- What do the two functions describe about the position of the connecting axle in the small wheel?
- Explain how the ratio of the radii of the two wheels relates to the dilation factor.

Shifting up and shifting down

Exercise

61 Investigating vertical shift.

- (a) Investigate the function $y = \cos \theta - 1$ by plotting points (you decide which points to use) and drawing a smooth curve through them on graph paper.

Do the same for $y = \cos \theta$. Choose your vertical scale (on the output-axis) so that the maximum and minimum points will not end up off the grid.

What do you notice about the graph compared to the graph of $y = \cos \theta$?

- (b) Investigate the function $y = \sin \theta + 2$ by plotting points (you decide which points to use) and drawing a smooth curve through them on a clean sheet of graph paper.

Do the same for $y = \sin \theta$. Choose your vertical scale (on the output-axis) so that the maximum and minimum points will not end up off the grid.

What do you notice about the graph compared to the graph of $y = \sin \theta$?

What have we learned?

It may not look like it, but if you draw a line parallel to the y -axis anywhere through the two graphs, the line segment between the two points where the line goes through the graphs is exactly 2 units (as shown in the graph above with line segments a to i).

In Exercise 61 the graph of $y = \cos x - 1$ is just the graph of $y = \cos x$ translated downwards through 1 unit.

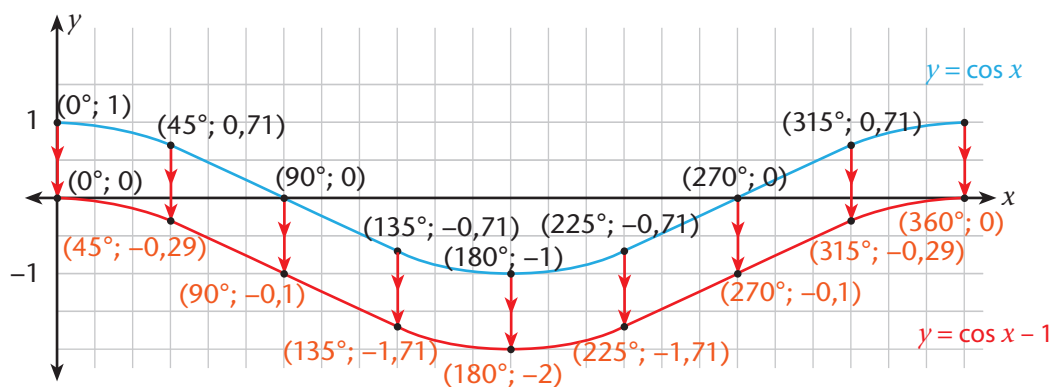

Some terminology to describe what we have seen

Translation: A translation is a movement in one direction without changing orientation, or contracting, or dilating.

The graph of $g(x) = \sin \theta + 2$ is the graph of $f(x) = \sin \theta$ translated vertically upwards through 2 units.

The graph of $y = \cos \theta - 1$ is the graph of $y = \cos \theta$ translated vertically downwards by 1 unit.

Exercises More vertical shift (graph paper required)

- 62 Draw up a table and plot the function $f(x) = \sin x - 1$ on the domain $x \in [0^\circ; 180^\circ]$, using points starting at 0° with intervals of 30° . Draw a smooth curve through your points and label it f .
- (a) On your graph paper, identify and mark all points that are a half a unit above the points you plotted. Draw a smooth curve through these points. Label the curve g .
 - (b) Give the range of f .
 - (c) Give the coordinates of the x - and y -intercepts of f .
 - (d) Write down the expression for the function: $g(x) = \dots$
 - (e) Give the coordinates of the turning point of g .
 - (f) Give the range of g .
 - (g) Read off the approximate x -intercepts of g . Confirm how accurate you have been by calculating the value of the first x -intercept (which lies between 0° and 90°).

Exercises Optional

Let's return to the situation of the Ferris wheel. You'll need a clean sheet of graph paper.

This is the companion to Exercise 62. It is important for similar reasons. Important links are made between the two ways of representing trigonometric relationships on the Cartesian plane. Also, it is a practical example of a vertical shift problem.

- 63 Let us suppose that the wheel has a diameter of 20 m, that the main axle is 14 m above the ground, and that the floor of the cradle is 2,5 m below the axle connecting it to the circumference of the wheel.

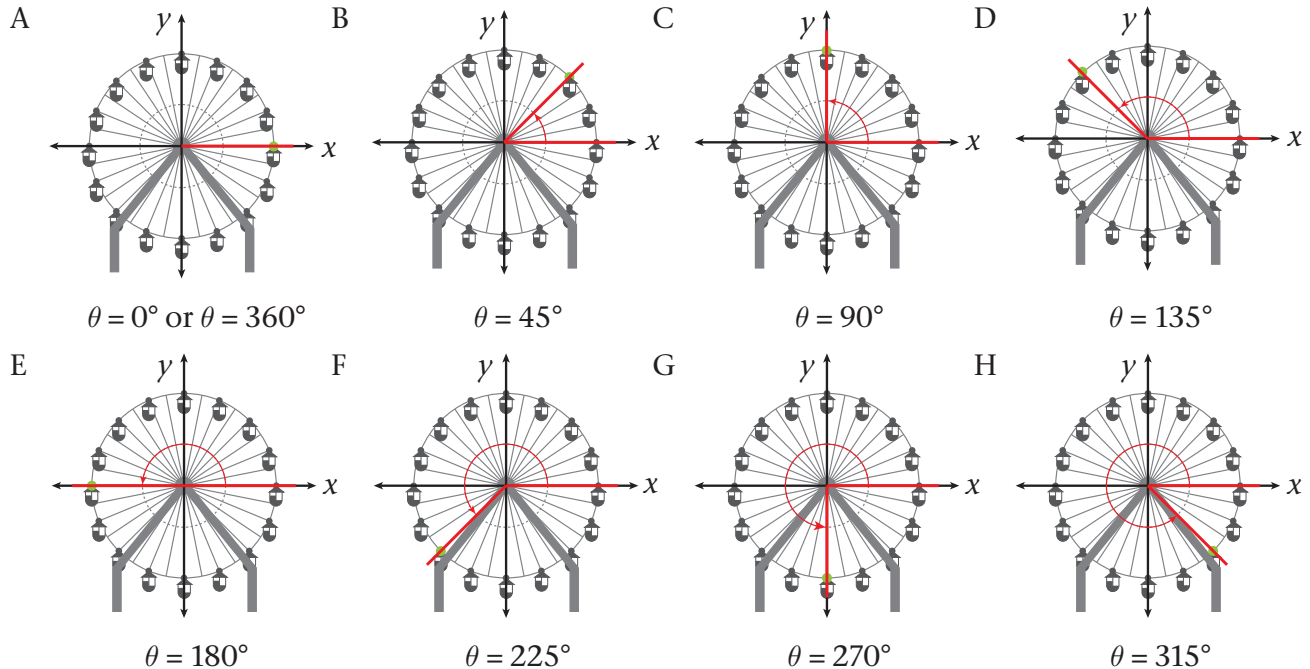

Since $\sin \theta = \frac{y}{10}$, the y -coordinate of the position of the connecting axle is $y = 10 \sin \theta$ in metre.

- (a) Copy the following table and complete the second column. Leave the third for later. Round off values to one decimal place.

θ	Height of connecting axle above/below main axle: $v(\theta) = 10 \sin \theta$ in metres	Height of cradle floor above the ground in metres
0°		
45°		
90°		
270°		
360°		

- (b) Plot the $(\theta; v(\theta))$ values on a sheet of prepared graph paper. Use a vertical scale of one block to 2 m.
- (c) Draw a smooth curve through your points. Make sure it looks like the sine graphs we have drawn. If you need extra points to draw a neater curve, then add some extras. You be the judge.

- (d) Indicate the coordinate on your graph where the connecting axle is:
- at its highest position above the central axle of the wheel
 - at its lowest position below the main axle
 - at its left-most position and at its right-most position
- (e) Are you satisfied that the function $y = 10 \sin \theta$ takes angles for different positions of the wheel as inputs? Are you satisfied that its output values give the height of the connecting axle above or below the level of the main axle? Make quite sure that you are.

How high above the ground are you at different positions of the cradle? Two possible positions are:

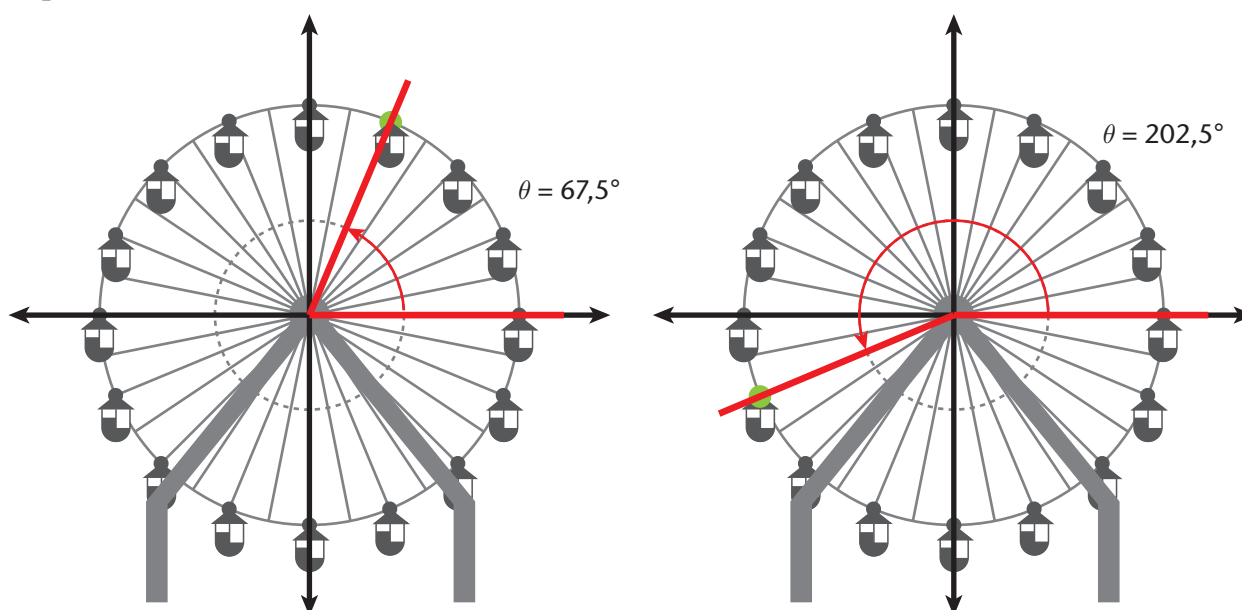

- (f) Show by calculation that the angles in the two diagrams are correct.
- (g) Calculate the y -coordinates of the positions of the connecting axle.
- (h) Use your solutions in (g) and the fact that the main axle is 14 m above the ground to show that the connecting axle is 20,7 m above the ground in the first position, and 7,7 m above the ground in the second position.
- (i) Now, fill in the values in the empty column in your table. Plot the values for the different angles on the same sheet of graph paper you used before. Draw a smooth curve.
- (j) The graph you have plotted in (i) is a translated form of the graph of function v . Let us call it V (the 'v' and 'V' stand for vertical). What is the value of C in $V(\theta) = 10 \sin \theta + C$?
- (k) The floor of the cradle is 2,5 m below the connecting axle. Write down an expression for the height above the ground that the floor of the cradle (and you, the rider) will be for different values of θ . Describe how the graph of this function will compare with the other two.

64 The graphs of $y = \sin x$, $y = \cos x$, and $y = \tan x$ are shown below.

Use the graphs to determine when

• $y > 0$

• $y = 0$

• $y < 0$

Give your answers in interval notation and say which quadrants the intervals correspond to.

(a) $y = \sin x$

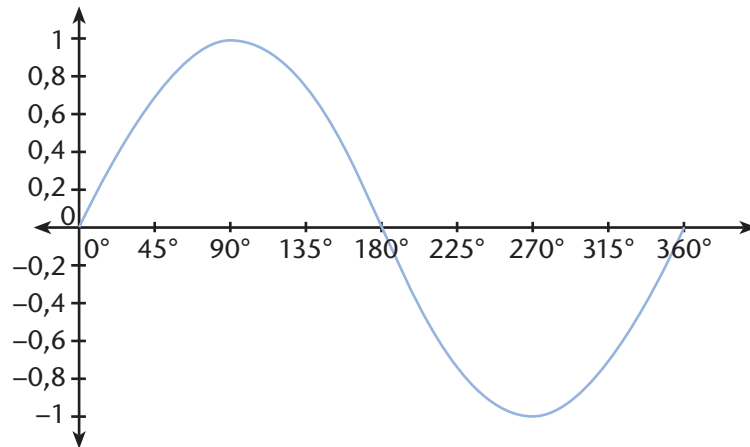

(b) $y = \cos x$

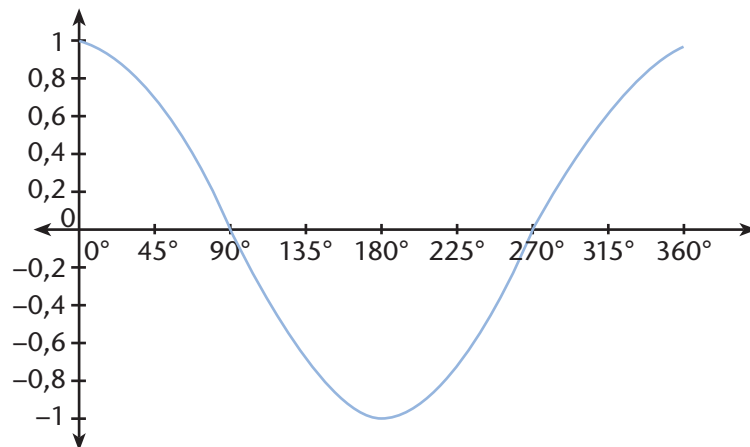

(c) $y = \tan x$

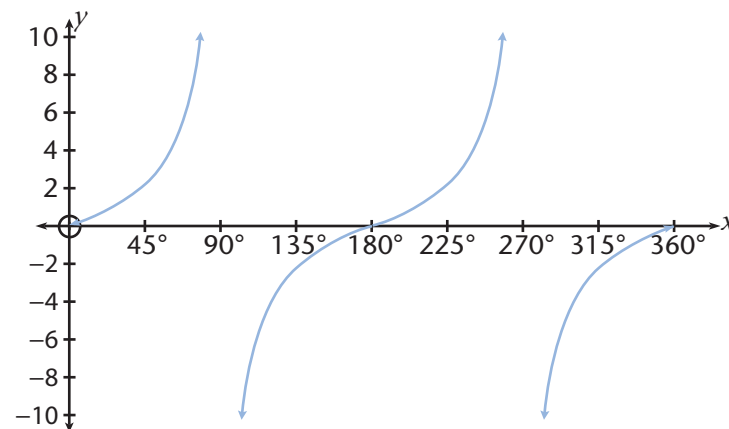

Compare your results with the results you obtained in Exercises 21 and 23. The graphs are another way of remembering/figuring out the signs of the three basic trigonometric functions in each quadrant.

- 65 In electrical technology, when the armature of a simple dynamo makes one full rotation, a voltage is induced across the two slip rings that form a sinusoidal curve:

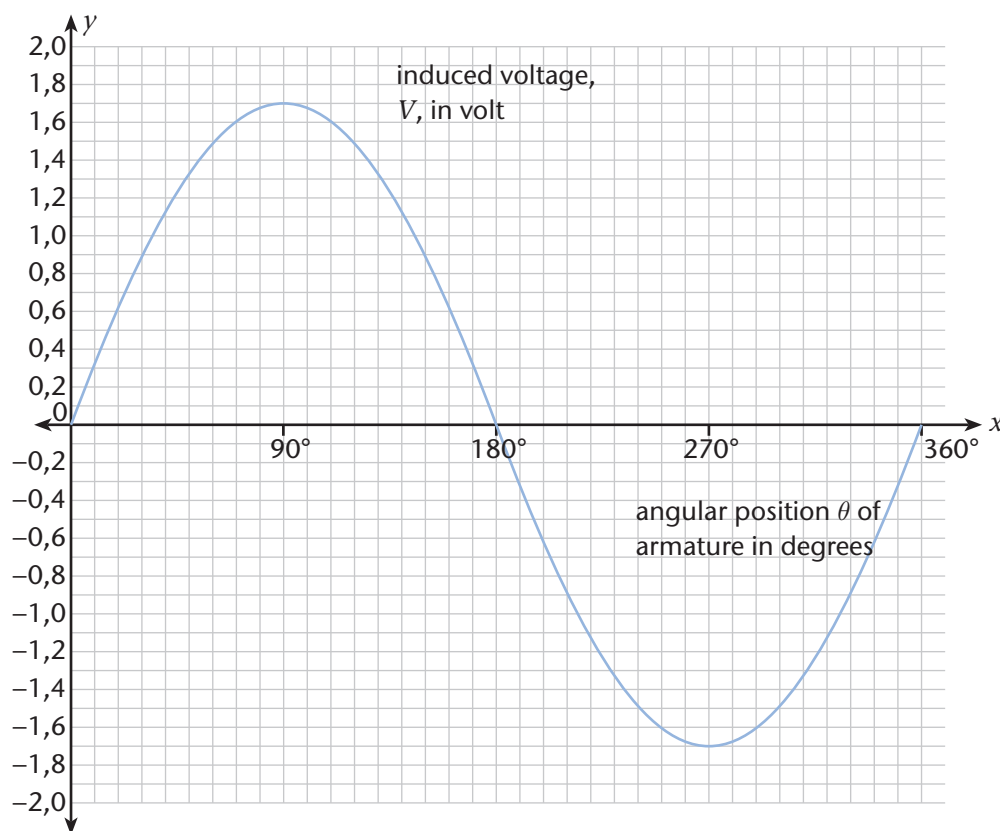

- What is the maximum voltage induced across the rings?
- Determine the angles for which the magnitude of induced voltage is 1 V.
- Determine the interval of angular positions for which the induced voltage has a magnitude that is less than or equal to 1,5 V.
- Write down the equation of voltage as a function of angular position.

If one full rotation of the armature takes 0,2 s, starting at $\theta = 0^\circ$, at which times will the induced voltage magnitude be

- zero?
- maximum?
- greater than 1,5 V?

Note: voltage magnitude is just the value of the voltage without the sign. This is called the **absolute value** or **modulus** of the voltage.

- 66 When a bolt is turned through one full revolution it moves through a distance in the nut, called the lead. A bolt with a single start thread has the lead equal to the pitch.

The length of thread corresponding to the lead is shown in red. It is equal to $2\pi r_m$, the circumference of a circle of radius r_m , the mean radius of the thread.

The lead is perpendicular to the thread. The angle the direction of the thread makes with the radius of the bolt is called the lead angle θ .

If we 'unwind' the red line without changing its length, we can draw the following right-angled triangle:

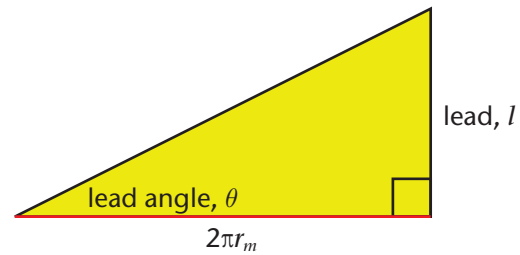
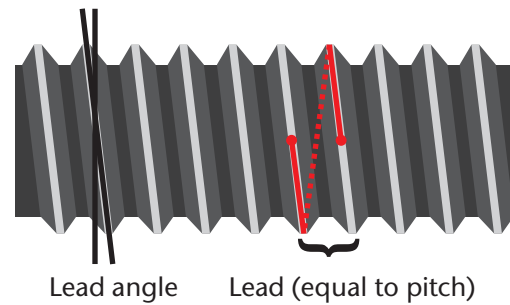

The following graph gives the lead, in mm, of bolts – all with the same mean thread radius – as a function of their lead angle in degrees:

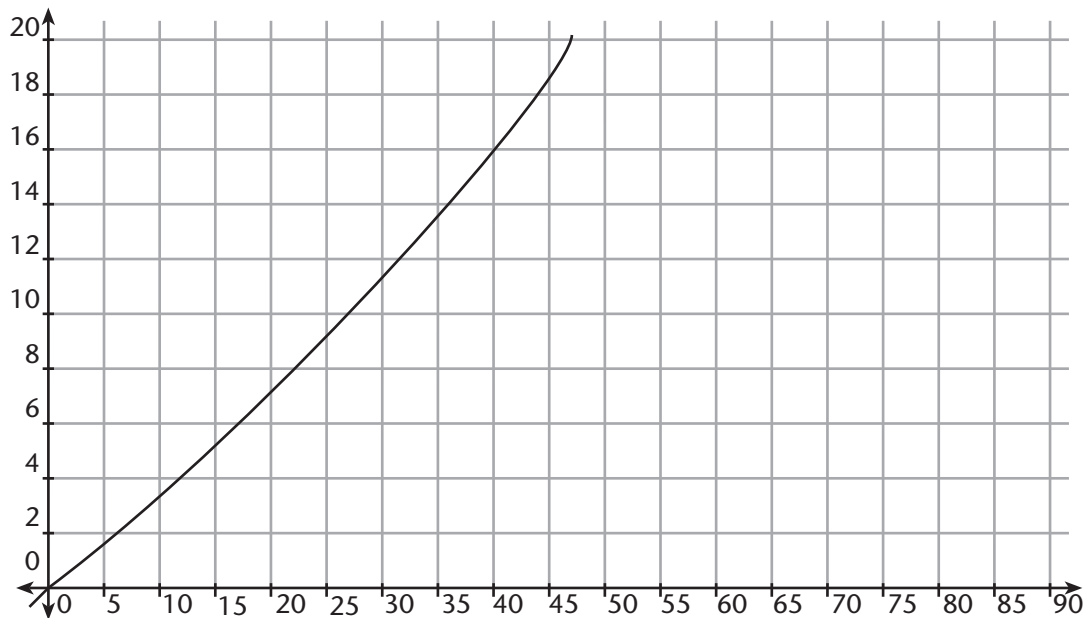

- Give the domain and range of the lead function in interval form.
- Is it practical to thread bolts with lead angles from the entire domain of the lead function?
- Read the values of the lead off the graph for the following lead angles: 5° , 20° , 45°
- Read off the lead angles for the following values of the lead: 1 mm, 4 mm, 15 mm
- Determine the lead function in the form $l(\theta) = \dots$
- Calculate the value of the mean thread radius for the bolts represented by the lead function.

6.12 Summary

The trigonometric functions for right-angled triangles:

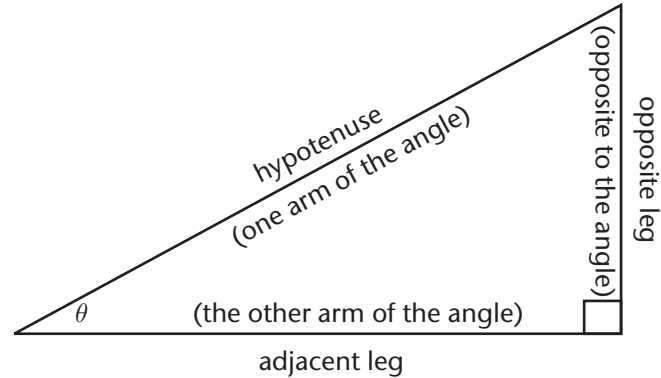

The three basic functions:

- Domain for all three functions: $0^\circ < \theta < 90^\circ$
- Range for sine: $0 < \sin \theta < 1$
- Range for cosine: $0 < \cos \theta < 1$
- Range for tangent: $\tan \theta > 0$

$$\sin \theta = \frac{\text{opp}}{\text{hyp}} \quad \cos \theta = \frac{\text{adj}}{\text{hyp}} \quad \tan \theta = \frac{\text{opp}}{\text{adj}}$$

The three inverse functions of sine, cosine, and tangent:

- Domain for \sin^{-1} : $0 < \text{input ratio} < 1$
- Domain for \cos^{-1} : $0 < \text{input ratio} < 1$
- Domain for \tan^{-1} : $\text{input ratio} > 0$
- Range for all three functions: $0^\circ < \text{output angle} < 90^\circ$

$$\sin^{-1}\left(\frac{\text{opp}}{\text{hyp}}\right) = \theta \quad \cos^{-1}\left(\frac{\text{adj}}{\text{hyp}}\right) = \theta \quad \tan^{-1}\left(\frac{\text{opp}}{\text{adj}}\right) = \theta$$

The three reciprocal functions of sine, cosine, and tangent:

- Domain for all three functions: $0^\circ < \theta < 90^\circ$
- Range for cosecant: $\text{cosec } \theta > 1$
- Range for secant: $\sec \theta > 1$
- Range for cotangent: $\cot \theta > 0$

$$\begin{aligned} \text{cosec } \theta &= \frac{\text{hyp}}{\text{opp}} & \sec \theta &= \frac{\text{hyp}}{\text{adj}} & \cot \theta &= \frac{\text{adj}}{\text{hyp}} \\ \text{cosec } \theta &= \frac{1}{\sin \theta} & \sec \theta &= \frac{1}{\cos \theta} & \cot \theta &= \frac{1}{\tan \theta} \end{aligned}$$

The Cartesian definitions of the trigonometric functions

For a point $P(x; y)$

- at angle θ anti-clockwise from the positive x -axis,
- and a distance r from the origin, where $r = OP = +\sqrt{x^2 + y^2}$

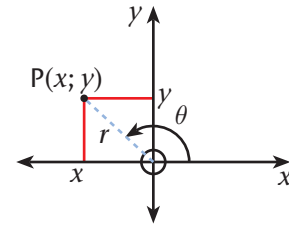
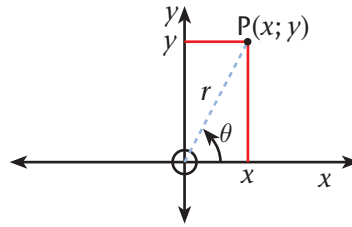

The three basic functions:

- Domain for sine and cosine: $0^\circ \leq \theta \leq 360^\circ$
- Domain for tangent: $0^\circ \leq \theta \leq 360^\circ$ but $\theta \neq 90^\circ$ and $\theta \neq 270^\circ$
- Range for sine: $0 \leq \sin \theta \leq 1$
- Range for cosine: $0 \leq \sin \theta \leq 1$
- Range for tangent: $\tan \theta$ any real number except 0

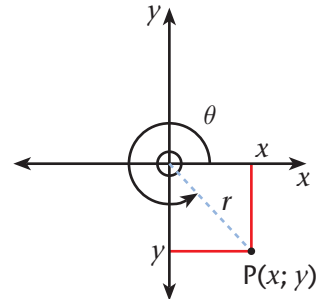
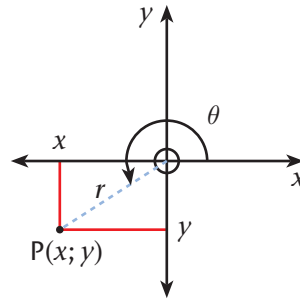

$$\sin \theta = \frac{y}{r} \quad \cos \theta = \frac{x}{r} \quad \tan \theta = \frac{y}{x}$$

Properties of the three basic functions:

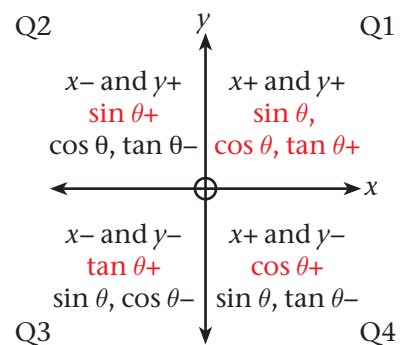
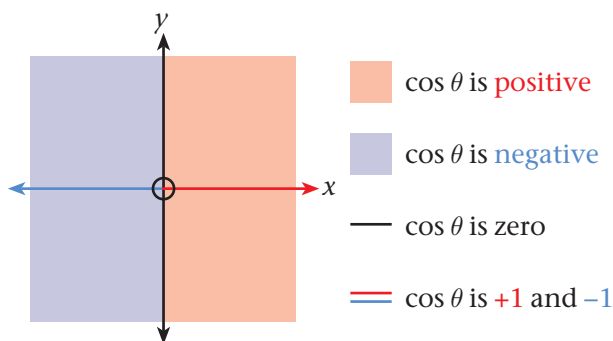
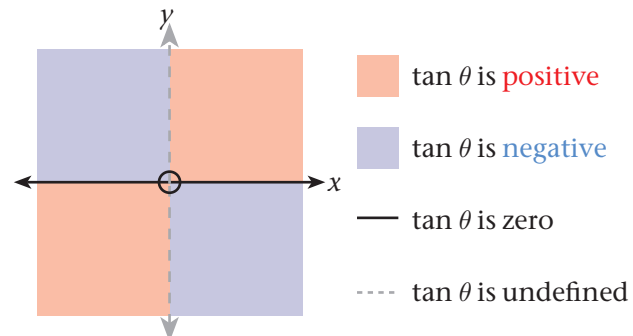
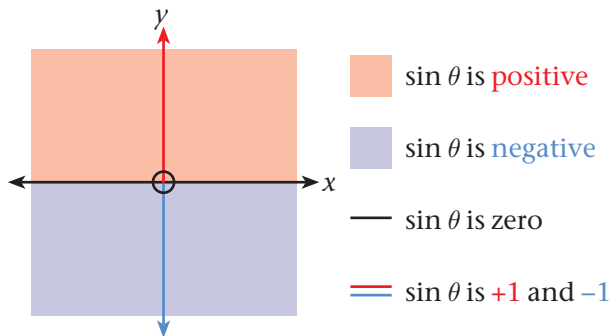

The three reciprocal functions of sine, cosine, and tangent:

$$\begin{aligned} \operatorname{cosec} \theta &= \frac{\text{hyp}}{\text{opp}} & \sec \theta &= \frac{\text{hyp}}{\text{adj}} & \cot \theta &= \frac{\text{adj}}{\text{hyp}} \\ \operatorname{cosec} \theta &= \frac{1}{\sin \theta} & \sec \theta &= \frac{1}{\cos \theta} & \cot \theta &= \frac{1}{\tan \theta} \end{aligned}$$

Effects of coefficient a on graphs

The functions, $y = a \sin \theta$, $y = a \cos \theta$, and $y = a \tan \theta$, are the graphs of the functions

$$y = \sin \theta \qquad y = \cos \theta \qquad y = \tan \theta$$

- unchanged when $a = 1$
- reflected around the horizontal axis when $a < -1$
- dilated (expanded) from the horizontal axis when $a > 1$
- contracted towards the horizontal axis when $0 < a < 1$
- dilated from and reflected around the horizontal axis when $a < -1$
- contracted towards and reflected around the horizontal axis when $-1 < a < 0$

Effects of term q on the graph

The graph of the functions, $y = \sin \theta + q$, $y = \cos \theta + a$ are the graphs of the functions

$$y = \sin \theta \qquad y = \cos \theta$$

- translated upwards from the horizontal axis when $q > 0$.
- translated downwards towards the horizontal axis when $q < 0$.
- unchanged when $q = 0$.

What you must be able to do from this chapter

For right-angled triangles:

- given two sides, calculate the third side, the ratios of any two sides, and the two acute angles
- given the ratio of any two sides, calculate the acute angles and any other ratios of two sides
- given an acute angle and a side, calculate the other acute angle and the remaining two sides and ratios of any two sides
- given an angle, calculate the ratio of any two of the sides
- be able to identify right-angled triangles in problems
- be able to solve problems involving angles, sides, and ratios of the sides of right-angled triangles

For the Cartesian plane

- represent the trigonometric information on a diagram
- be able to determine the correct signs of the functions in the four quadrants
- given any angle from 0° to 360° , calculate the output value of any of the functions
- given any coordinate, calculate the angle at which the point is the radial distance of the point from the origin, and any of the values of the functions
- be able to combine the above skills to solve problems involving angles between 0° and 360° , and distances or ratios of distances

For graphing the functions

- be able to generate a table of input-output pairs correctly (one at a time or using your calculator TABLE functionality)
- be able to scale a sheet of graph paper correctly
- be able to plot the (*input*; *output*) coordinate pairs on your scaled sheet of graph paper
- be able to draw a smooth curve through the points you have plotted
- be able to identify important graph characteristics such as turning points, whether the graph is increasing or decreasing, where the intercepts are any asymptotes
- be able to read input or output values from a graph
- be able to identify Domains and Ranges on graphs
- be able to explain the effects of a and q mentioned earlier

6.13 Consolidation exercises

1 Consider the diagram below.

- Determine $\cot \theta$, expressing your answer as a fraction
- Determine $\sin \theta$, expressing your answer as a fraction.
- Determine $\cos \theta$ expressing your answer as a fraction.
- Determine $\sec \theta$ expressing your answer as a fraction.

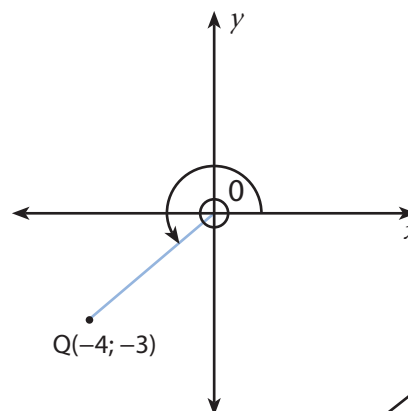

2 Calculate $\tan \beta$ if $\sin \beta$ and $\cos \beta < 0$. Draw your own sketch.

3 If the distance of a person from a tower is 100 m and the angle of elevation of the top of the tower with the ground is 35° , what is the height of the tower in meters?

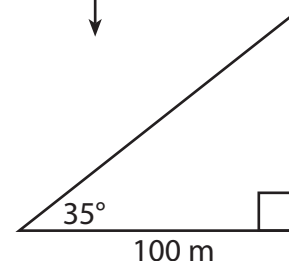

4 Dumi and Nathi are standing on the same side of a tall building. They notice the angle of elevation to the top of the building to be 30° and 60° respectively. If the height of the building is 120 m, find the distance between Dumi and Nathi in meters. Draw your own sketch.

5 Solve the following equations for $\theta \in [0^\circ; 360^\circ]$. Give your answers to one decimal place.

(a) $\sin \theta = 0,234$

(b) $\cot \theta = \tan 53^\circ + \sin 233^\circ$

6 Determine the equations of the following graphs.

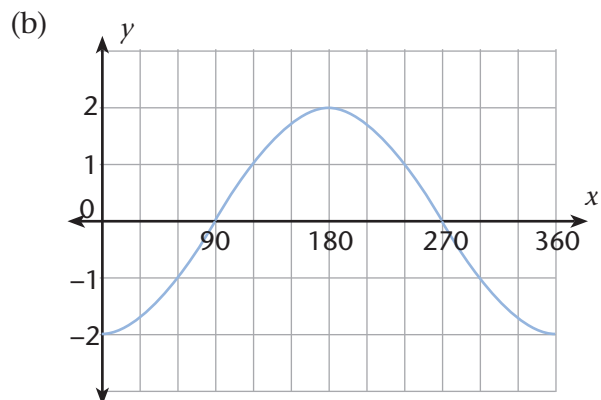
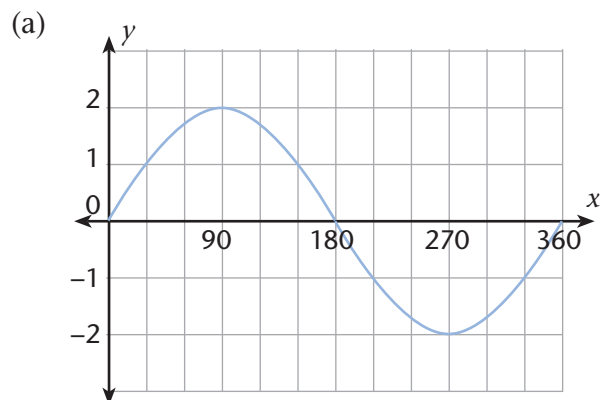

7 There is a Ferris wheel at Gold Reef City. Riders get on at position A which is 3 metres above the ground. (Refer to the diagram below). The highest point of the ride is 15 metres above the ground. The height above the ground is modelled by the formula:

$$h(\theta) = a \cos \theta + b \text{ for } \theta \in [0^\circ; 360^\circ]$$

The ride takes 40 seconds for one complete revolution.

(a) Show that $a + b = 3$

(b) Show that $-a + b = 15$

(c) Siphon and his friends spent 24 minutes on a ride. How many revolutions did the ride take while Siphon and his friends were on a ride?

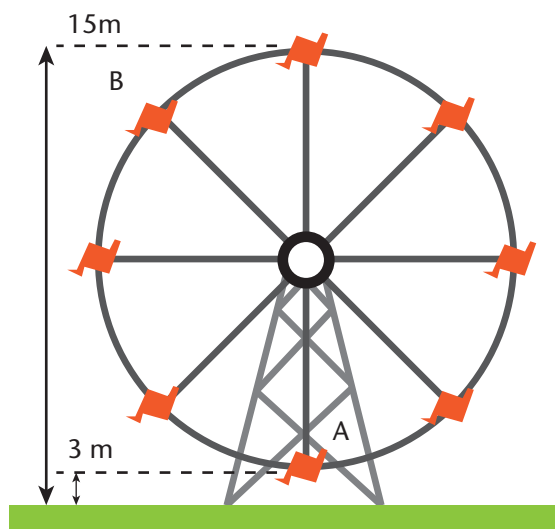

8 Determining the height of a very tall building measuring two angles and one distance:

The angles of elevation of the top of a tower labelled T, is measured from two points, A and B. The angles are 32° and 47° respectively. The points A, B, and S all lie along the same line. AB is measured to be 35 m.

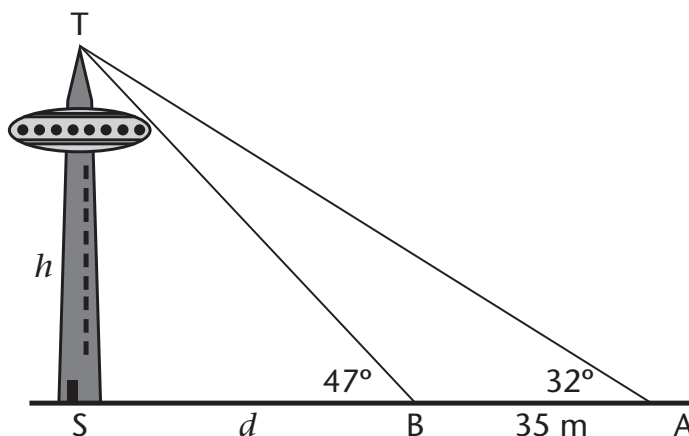

The height of the tower is represented by h . Let the distance between position B and the base of the tower be represented by d .

- Express $\tan 47^\circ$ in terms of h , and d .
 - Express $\tan 32^\circ$ in terms of h , d , and the distance AB.
 - Calculate the height of the tower. (**Hint:** eliminate d .)
 - Calculate the distance TB.
- 9 If $x = 27,3^\circ$ and $y = 48,5^\circ$, use a calculator to determine the following (round off your answer to TWO decimal places) :
- $\sin x$
 - $\sqrt{1 - \sin^2 x}$
 - $\sin(y - x) + \sin(y + x)$

-
- 10 Solve the following equation, where $0^\circ \leq \theta \leq 90^\circ$. Show every important step, and round your final answer to THREE decimal places :

$$\frac{2\sin(\theta - 10^\circ) + 0,2}{3} = 0,27$$

- 11 If $\cos \theta = \frac{7}{25}$ and θ is not in the first quadrant, determine the following WITHOUT calculating the angle θ (Give your answers in RATIONAL form):
- (a) $\sin \theta$
 - (b) $\operatorname{cosec} \theta + \sec \theta$
 - (c) $\tan \theta$
- 12 (a) Draw a neat sketch graph of $y = -\tan x$. Do this for the domain $45^\circ \leq x \leq 225^\circ$. Show the x - and y -intercepts on your graph.
- (b) Give the maximum y -value of a point on the graph.
 - (c) On your graph, show where one finds the angles x that make $y = 1$. Label the two points P and Q.
 - (d) Show the domain and range on your graph using the axes. Remember that the two axes are number lines.
- 13 According to a Chinese legend from the Han Dynasty (206 BC – 220 AD), General Han Xin flew a kite over the palace of his enemy to determine the distance between his troops and the palace. The ground between his position and the palace was level.
- (a) If the General let out 800 m of string, and the string made an angle of 35° with the level ground, approximately how far away was the palace from his position?
(Hint: First draw a triangle!)
 - (b) If the kite rose so that he had to let out 150 m more string to keep the kite above the palace, what would the angle of elevation of the kite be now?

APPENDIX 1

Some Revision: What is the graph of a function?

You have represented straight line functions like $y = 2x + 1$ as graphs in the past. We can do this for any function. All we need is enough (*input; output*) coordinate pairs to plot.

In other words, the horizontal axis is a number line for input values and the vertical axis is a number line for output values. We usually call these the x - and y -axes (because we usually represent input values with the letter symbol x and the output values by y).

Example

In the previous straight line function, the following are some of the (*input; output*) pairs (check these by substituting): $(-5; -9)$; $(-1; -1)$; $(0; 1)$; $(1, 3)$; $(4; 9)$

We can plot these points on a Cartesian Grid:

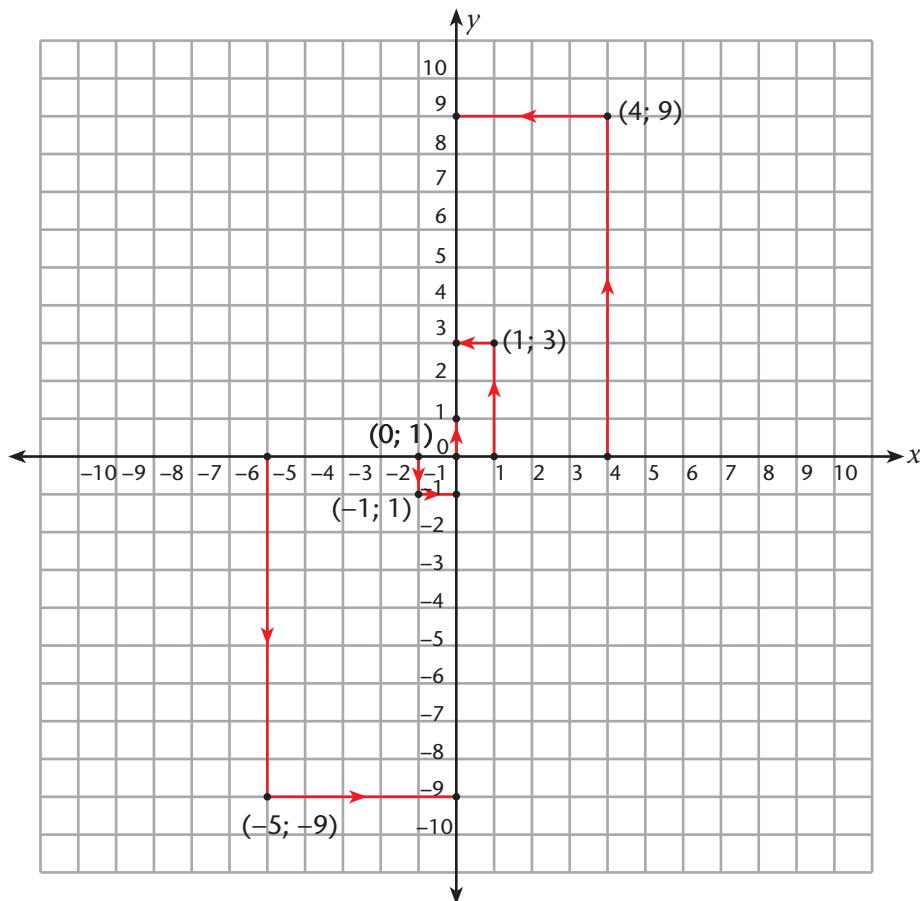

Notice how we can 'look up' the output values on the y -axis from the input values along the x -axis. Follow the dashed lines, along the grid, in the direction of the arrows from input to output.

We can draw a smooth 'curve' (here a straight line) through all the plotted points:

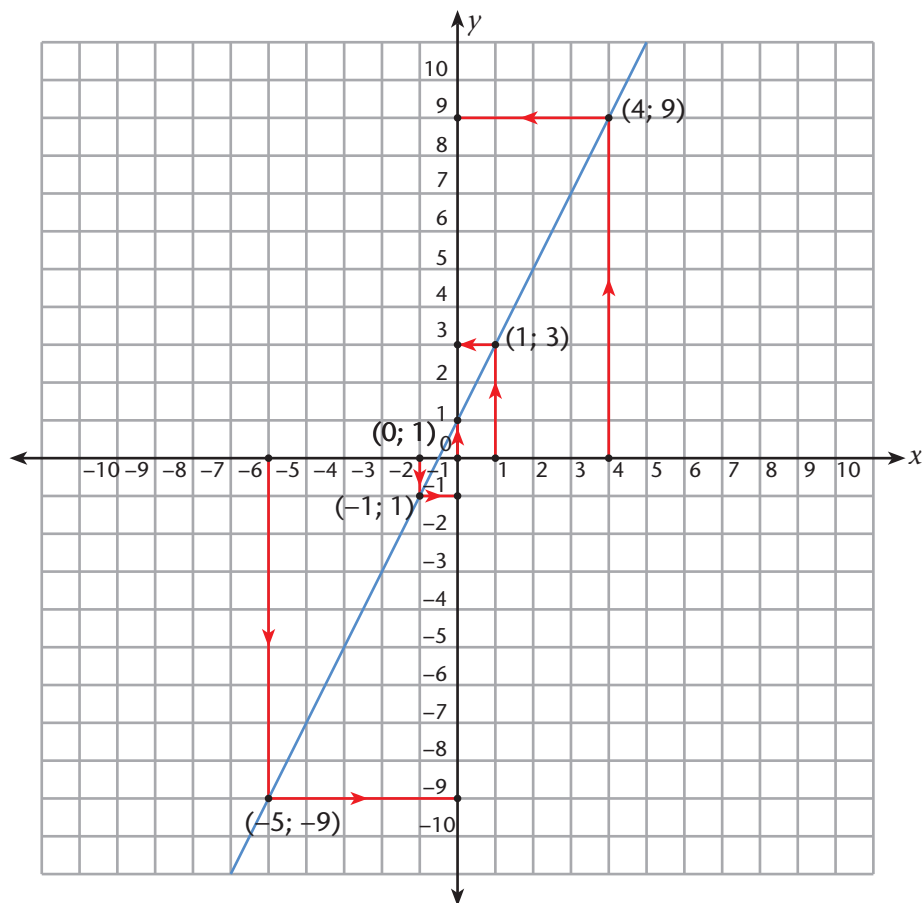

Now we can use the graph to 'look up' other input-output pairs. Two examples are shown below:

- red: the input value is -3 , 8 . Using the grid, we can read off the corresponding output value on the y -axis
- green: here the output, 6 , is known; if we follow the gridlines 'in reverse' we can read off what the input must be to give an output of 6 .

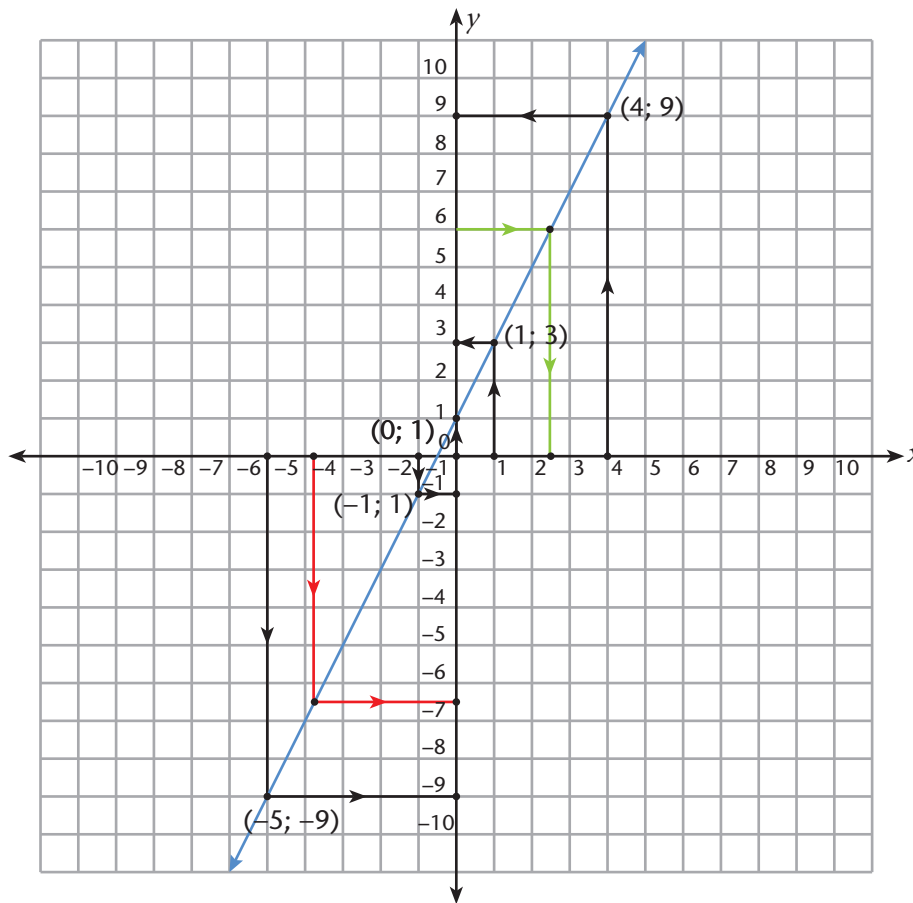

Make the readings and confirm them using your calculator.

7 FUNCTIONS AND GRAPHS

In this chapter, you will:

- use the point-by-point plotting method for sketching the graph of an equation in two variables
- with this method, you construct a table of values that consists of several solution points of the equation and then plot the solution points on the Cartesian plane

7.1 Function notation

Function notation is one of many other conventions that we use to represent and name relationships between the values of two variables.

The definition of a function consists of the following components:

- the name of the function
- the variable that represents a value to evaluate the function
- a rule that says how to calculate the function's output for the given input value

The number that results from applying the rule to a specific input value is called an output value and is represented by $f(x)$.

Consider the function given: $f(x) = 3x + 2$

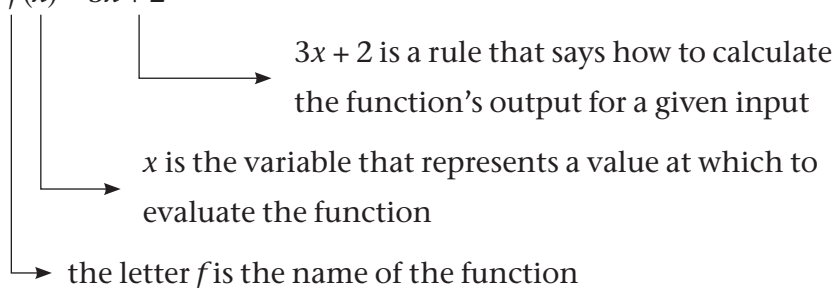

7.2 Revision of linear functions

Work through the examples to revise what you have learned about linear functions.

Worked examples

A. Problem:

(a) Copy and complete the table below for the functions defined by $f(x) = x$.

$$\begin{array}{cccccc} f(-5) = -5 & f(-4) = -4 & f(-3) = -3 & f(-2) = -2 & f(-1) = -1 & f(0) = 0 \\ f(1) = 1 & f(2) = 2 & f(3) = 3 & f(4) = 4 & f(5) = 5 & \end{array}$$

Solution:

(a)

x	-5	-4	-3	-2	-1	0	1	2	3	4	5
$f(x)$	-5	-4	-3	-2	-1	0	1	2	3	4	5

(b) Draw the graph of the function by plotting the coordinates on the Cartesian plane.

(c) The x -intercept: $(0; 0)$

(d) The y -intercept: $(0; 0)$

(e) Domain: $x \in \mathbb{R}$

(f) Range: $y \in \mathbb{R}$

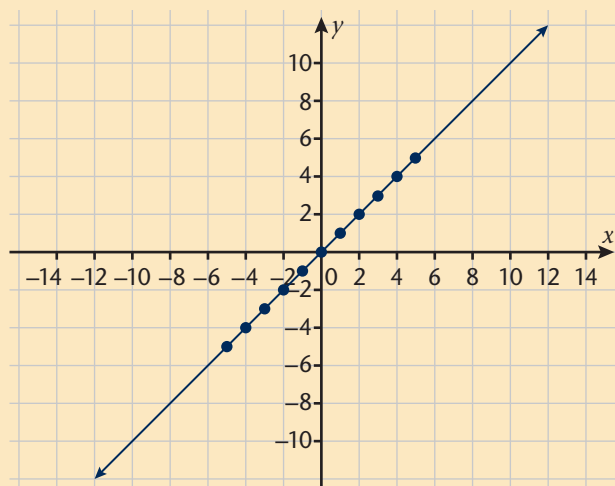

Worked example

B. Problem: A graph of a certain function is given below.

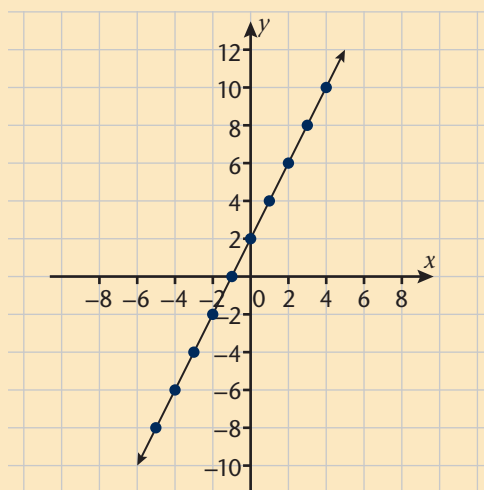

Copy and complete the table for this function by reading the values from the graph.

Solution:

x	-5	-4	-3	-2	-1	0	1	2	3	4	5
$f(x)$	-8	-6	-4	-2	0	2	4	6	8	10	12
$(x; f(x))$	$(-5; -8)$	$(-4; -6)$	$(-3; -4)$	$(-2; -2)$	$(-1; 0)$	$(0; 2)$	$(1; 4)$	$(2; 6)$	$(3; 8)$	$(4; 10)$	$(5; 12)$

(b) x -intercept: $(-1; 0)$

(c) y -intercept: $(0; 2)$

(d) Domain: $x \in \mathbb{R}$

(e) Range: $y \in \mathbb{R}$

The **domain** is the set of all possible input values to which the rule applies.
The **range** is the set of all possible output values to which the rule applies.

Exercises

1 Copy and complete the table for the functions defined by:

(a) $f(x) = -x$

(b) $g(x) = x + 5$

(c) $h(x) = -x - 1$

x	-5	-4	-3	-2	-1	0	1	2	3	4	5	6
$f(x)$												
$g(x)$												
$h(x)$												

2 Draw the graphs of each function in exercise 1 above on the same set of axes.

3 Complete the table below for the three functions drawn in exercise 2.

Function	x -intercept	y -intercept	Domain	Range
$f(x) = -x$				
$g(x) = x + 5$				
$h(x) = -x - 1$				

4 Use the intercept method to sketch the graphs of the following functions:

(a) $y = x + 2$

(b) $y = x - 3$

(c) $y = 2x + 1$

(d) $y = -2x + 4$

(e) $x = y - 4$

(f) $x = y$

(g) $y = -3x + 6$

5 A graph of a certain function $g(x)$ is given below.

Copy the table below for the function $g(x)$. By reading of corresponding x - and y -values of points on the graph of $g(x)$, complete the table by writing down specific corresponding x - and y -values.

x						
$y = g(x)$						

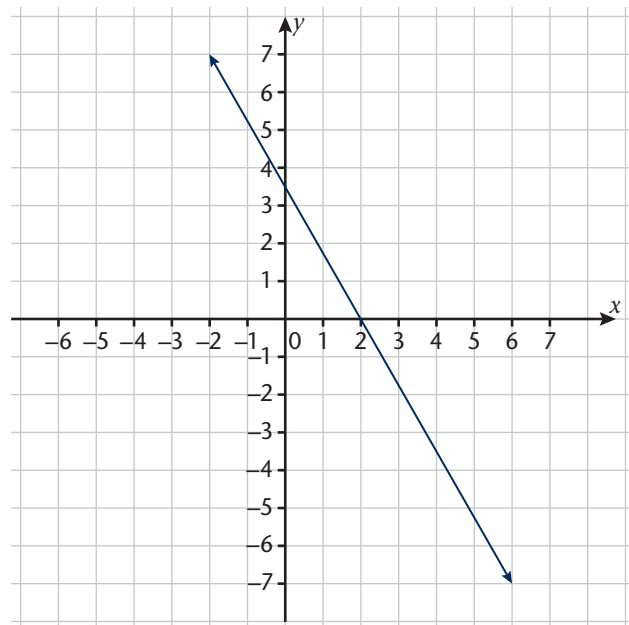

7.3 Quadratic function $y = ax^2$

Worked example

Problem: Consider the function defined by $f(x) = x^2$.

Solution:

Step 1: Calculate the output values of $f(x) = x^2$ for integer x -values -4 to $+4$.

$$f(-3) = (-3)^2 = 9$$

$$f(0) = (0)^2 = 0$$

$$f(3) = (3)^2 = 9$$

$$f(-2) = (-2)^2 = 4$$

$$f(1) = (1)^2 = 1$$

$$f(4) = (4)^2 = 16$$

Step 2: Represent the function $f(x) = x^2$ by means of a table.

x	-4	-3	-2	-1	0	1	2	3	4
$f(x)$	16	9	4	1	0	1	4	9	16

Step 3: Draw the graph representing the function $f(x) = x^2$.

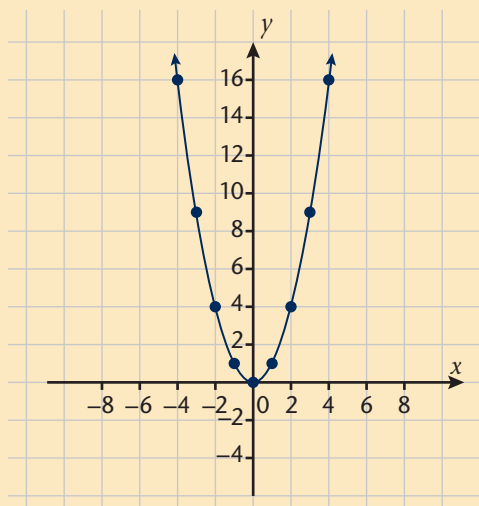

Step 4: Identify the shape of the graph.

The graph opens upwards (shape).

Step 5: Identify the intercepts of the graph.

The graph intercepts the x -axis at one point $(0; 0)$.

The x -intercepts are also called the roots.

An **intercept** is a point at which the graph intersects the x - or y -axis.

Step 6: What is the turning point?

This graph has a turning point at $(0; 0)$.

Step 7: What is the domain?

The domain is the set of all real values of x . We write this as $x \in \mathbb{R}$ or $(-\infty; \infty)$.

Step 8: What is the range?

We can see from the graph that the smallest output value is 0.

We write this as $y \geq 0$ or $[0; \infty)$.

Step 9: Write down the axis of symmetry; the graph is symmetric about the y -axis.

Axis of Symmetry: if two points are symmetrical about the y -axis, then their y -coordinates are the same and they are on opposite sides and equal distance from the y -axis.

If two points are symmetrical about the x -axis, then their x -coordinates are the same and they are on opposite sides and equal distance from the x -axis

Exercise Quadratic function $y = ax^2$

6 Consider the function defined by $f(x) = x^2$ and $g(x) = -x^2$.

(a) Copy and complete the table below:

x	-4	-3	-2	-1	0	1	2	3	4
$f(x)$									
$g(x)$									

(b) Draw the graph of $g(x) = -x^2$ and $f(x) = x^2$ on the same system of axes.

(c) Copy and complete the table below.

Function	x -intercept(s)	y -intercept	Axis of symmetry	Turning point	Domain	Range	Shape
$f(x)$							
$g(x)$							

7.4 Quadratic function: $y = ax^2 + q$

Worked example

Problem: Consider the function defined by $f(x) = x^2$ and $h(x) = x^2 + 1$.

Solution: Step 1: Calculate the output values of $f(x) = x^2$ and $h(x) = x^2 + 1$ and write coordinates for each input value and output value.

Coordinates for:

$$f(x) = x^2:$$

$(-4; 16), (-3; 9), (-2; 4), (-1; 1), (0; 0), (1; 1), (2; 4), (3; 9), (4; 16)$

$$h(x) = x^2 + 1:$$

$(-4; 17), (-3; 10), (-2; 5), (-1; 2), (0; 1), (1; 2), (2; 5), (3; 10), (4; 17)$

Step 2: Represent the functions $f(x) = x^2$ and $h(x) = x^2 + 1$ by means of a table.

x	-4	-3	-2	-1	0	1	2	3	4
$f(x)$	16	9	4	1	0	1	4	9	16
$h(x)$	17	10	5	2	1	2	5	10	17

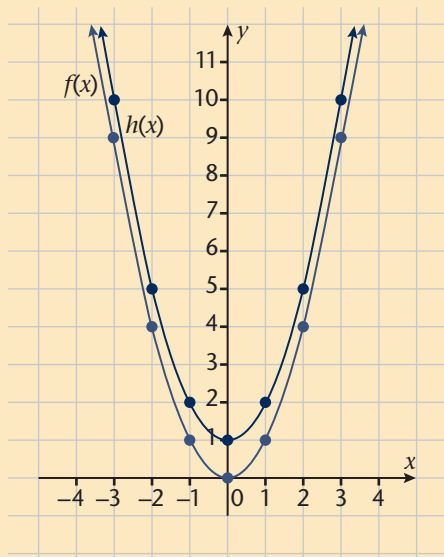

Step 3: The graph of $f(x) = x^2$ is already plotted for you on the system of axes. Plot the points for $h(x) = x^2 + 1$ on the same system of axes as $f(x) = x^2$.

Step 4: How are the graphs of $f(x) = x^2$ and $h(x) = x^2 + 1$ the same? (Talk about their shapes.)
The graphs of the functions defined by $f(x) = x^2$ and $h(x) = x^2 + 1$ both open upwards.

Step 5: How are the graphs of $f(x) = x^2$ and $h(x) = x^2 + 1$ different?

- (a) The turning point of the graph representing the function $f(x) = x^2$ is $(0; 0)$ but the turning point of the graph representing the function defined by $h(x) = x^2 + 1$ is $(0; 1)$.
- (b) The input values of both functions are the same but the output values of the function defined by $h(x) = x^2 + 1$ are 1 more than the output values of the function defined by $f(x) = x^2$.

Step 6: The domain of $h(x) = x^2 + 1$ is $x \in \mathbb{R}$.

Step 7: The range of $h(x) = x^2 + 1$ is $y \geq 1$.

Step 8: The equation for the axis of symmetry for the graph of $h(x) = x^2 + 1$ is $x = 0$ (y -axis).

Exercises Quadratic function $y = ax^2 + q$

7 Without drawing the graphs of the functions defined below, write down the coordinates of the turning points of the graphs representing each function.

- (a) $f(x) = x^2 + 2$
- (b) $f(x) = x^2 + 12$
- (c) $f(x) = x^2 + 21$
- (d) $f(x) = x^2 + 100$
- (e) $f(x) = x^2 + 121$

8 Draw graphs of the functions of (a), (c), and (d) on the same set of axes, and on a different set of axes draw graphs of the functions (b), (e) and (f).

- (a) $f(x) = x^2 + 5$
- (b) $f(x) = x^2 + 2$
- (c) $f(x) = x^2 + 3$
- (d) $f(x) = x^2 + 4$
- (e) $f(x) = x^2 + 7$
- (f) $f(x) = x^2 + 6$

9 Copy and complete the table below.

	Function	x -intercepts	y -intercepts	Coordinates of turning point	Domain	Range	Axis of symmetry
(a)	$f(x) = x^2 + 5$						
(b)	$f(x) = x^2 + 6$						
(c)	$f(x) = x^2 + 3$						
(d)	$f(x) = x^2 + 4$						
(e)	$f(x) = x^2 + 7$						
(f)	$f(x) = x^2 + 10$						

Worked example

Problem: Consider the graph of $v(x) = x^2 - 1$.

Solution:

Step 1: Copy and complete the table below.

x	-4	-3	-2	-1	0	1	2	3	4
$v(x)$	15	8	3	0	-1	0	3	8	15

Step 2: Draw the graph of $v(x) = x^2 - 1$ on the same system of axes as that of the function defined by $f(x) = x^2$.

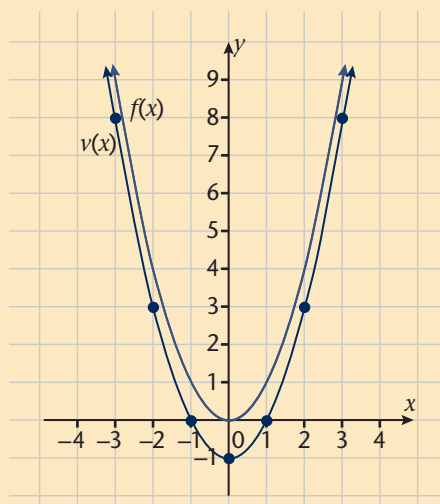

Step 3: The turning point of the graph of the function defined by $v(x) = x^2 - 1$ is $(0; -1)$.

Step 4: (a) The graph cuts the x -axis at $x = -1$ or $x = 1$.

(b) We can represent the points where the graph cuts the x -axis in coordinate form as $(-1; 0)$ or $(1; 0)$.

Step 5: (a) The graph cuts the y -axis at $y = -1$.

(b) We can represent the point where the graph cuts the y -axis in coordinate form as $(0; -1)$.

Step 6: The graph opens upwards.

Step 7: The domain of $v(x) = x^2 - 1$ is $x \in \mathbb{R}$.

Step 8: The range of $v(x) = x^2 - 1$ is $y \geq -1$.

Step 9: The equation for the axis of symmetry of $v(x) = x^2 - 1$ is $x = 0$ (y -axis).

Exercises Interpreting the graph

10 Draw graphs of the functions of (a), (c), and (d) on the same set of axes, and on a different set of axes draw graphs of the functions (b), (e) and (f).

- (a) $g(x) = x^2 - 4$ (b) $h(x) = x^2 - 9$ (c) $q(x) = x^2 - 16$
 (d) $p(x) = x^2 - 25$ (e) $r(x) = x^2 - 36$ (f) $s(x) = x^2 - 49$

11 Now, use the graphs you have drawn in exercise 10 above to complete the table given below. You should redraw the table in your exercise book.

	Function	x -intercepts	y -intercepts	Coordinates of turning point	Domain	Range	Axis of symmetry
(a)	$g(x) = x^2$						
(b)	$h(x) = x^2 - 4$						
(c)	$g(x) = x^2 - 16$						
(d)	$p(x) = x^2 - 25$						
(e)	$r(x) = x^2 - 36$						
(f)	$s(x) = x^2 - 49$						
(g)	$u(x) = x^2 - 121$						
(h)	$v(x) = x^2 - 81$						

Worked example

Problem: Consider the function defined by $w(x) = -x^2 + 1$.

Solution: Step 1: Copy and complete the table below.

x	-4	-3	-2	-1	0	1	2	3	4
$w(x)$	-15	-8	-3	0	1	0	-1	-8	-15

Step 2: Draw the graphs of $f(x) = -x^2$ and $w(x) = -x^2 + 1$ on the same system of axes.

Step 3: The coordinates of the turning point of the function defined by $w(x) = -x^2 + 1$ are (0; 1) and the coordinates of the turning point of the function defined by $f(x) = -x^2$ are (0; 0).

Step 4: The x -intercepts for the graph of $w(x) = -x^2 + 1$ are $x = -1$ or $x = 1$.

Step 5: The domain of $w(x) = -x^2 + 1$: $x \in \mathbb{R}$

Step 6: The range of $w(x) = -x^2 + 1$: $y \leq 1$

Step 7: Axis of symmetry of $w(x) = -x^2 + 1$ is $x = 0$ (y -axis).

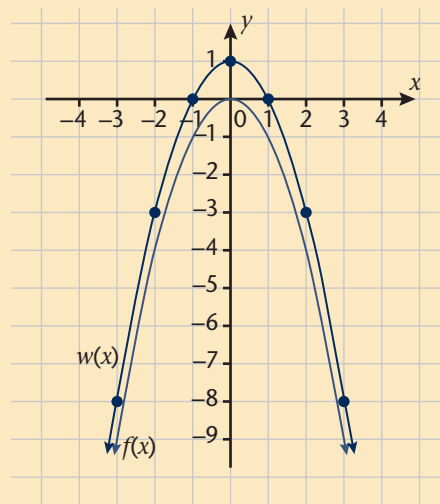

Exercises

12 Draw graphs of the functions of (a), (b), and (c) on the same set of axes, and on a different set of axes draw graphs of the functions (d), (e) and (f).

(a) $g(x) = -x^2 + 4$

(b) $h(x) = -x^2 + 9$

(c) $q(x) = -x^2 + 16$

(d) $p(x) = -x^2 + 25$

(e) $r(x) = -x^2 + 1$

(f) $v(x) = -x^2 + 81$

13 Copy and complete the table below.

	Function	x-intercepts	y-intercepts	Coordinates of turning point	Domain	Range	Axis of symmetry
(a)	$g(x) = x^2$						
(b)	$h(x) = -x^2 + 4$						
(c)	$q(x) = -x^2 + 16$						
(d)	$p(x) = -x^2 + 25$						
(e)	$r(x) = -x^2 + 36$						
(f)	$s(x) = -x^2 + 49$						
(g)	$u(x) = -x^2 + 121$						
(h)	$v(x) = -x^2 + 81$						

Exercise The value of q and graph $f(x) = ax^2$

14 Look back at the graphs of the functions of the form $f(x) = ax^2 + q$.

Use the table below to write down what you notice about how the value of q affects the graph $f(x) = ax^2 + q$:

	$q < 0$	$q > 0$
$a > 0$		
$a < 0$		

7.5 Exponential graphs $y = ab^x$

An exponential function is a function of the form $y = ab^x$ or $f(x) = ab^x$, b is a positive real number other than 1 and x can be any real number.

We will graph a given exponential function by first making a table of values and plotting the points on the Cartesian plane. When creating a table of values, it is very important to have different types of numbers; some negative, some positive, and 0.

A **horizontal line**, parallel to the x -axis, is a **horizontal asymptote** of a curve when the distance between coordinate points on the curve and the asymptote line continually decreases but never becomes zero as the x -coordinates of these points move to the right (increase) or move to the left (decrease).

Worked example

Problem: Draw the graph of $y = 2^x$.

Solution:

Step 1: Copy and complete the table below.

x	-6	-5	-4	-3	-2	-1	0	1	2	3	4	5	6
y	$\frac{1}{64}$	$\frac{1}{32}$	$\frac{1}{16}$	$\frac{1}{8}$	$\frac{1}{4}$	$\frac{1}{2}$	1	2	4	8	16	32	64

Step 2: Sketch the graph of $f(x) = 2^x$ by plotting the points on the Cartesian plane.

Step 3: Identify the features of the graph

1. Domain of $f(x) = 2^x$: $x \in \mathbb{R}$
2. Range of $f(x) = 2^x$: $y > 0$
3. Intercept of $f(x) = 2^x$: only the y -axis at $(0; 1)$.
4. As the values of x get smaller (from 6 to -6), the graph of the function gets closer and closer to the x -axis. We say there is a **horizontal asymptote** at the x -axis or $y = 0$.
5. The value of y increases as the values of x increases. We therefore say this is an increasing function.

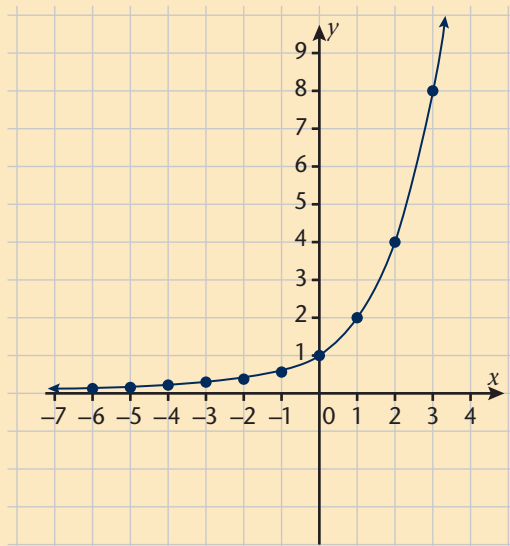

Exercises Exponential graphs

15 Draw each graph below on a separate set of axes:

(a) $g(x) = 3^x$

(b) $q(x) = 4^x$

(c) $t(x) = 5^x$

(d) $f(x) = 1,25^x$

(e) $h(x) = 2(5)^x$

(f) $y = 3(2)^x$

(g) $y = 2(2)^x$

(h) $y = 2(3)^x$

(i) $y = 2(4)^x$

16 Copy the table below in your exercise book. Use the graphs you have drawn in exercise 15 to complete the table below.

	Function	Intercept	Domain	Range	Asymptote
(a)	$g(x) = 3^x$				
(b)	$q(x) = 4^x$				
(c)	$t(x) = 5^x$				
(d)	$f(x) = 1,25^x$				
(e)	$h(x) = 2(5)^x$				
(f)	$y = 3(2)^x$				
(g)	$y = 2(2)^x$				
(h)	$y = 2(3)^x$				
(i)	$y = 2(4)^x$				

17 On the same set of axes as the ones you used to draw graphs in exercise 15(a) – (f), draw the graphs of:

(a) $y = -1(3)^x$

(b) $y = -1(4)^x$

(c) $y = -1(5)^x$

(d) $y = -1(1,25)^x$

(e) $y = -2(5)^x$

(f) $y = -3(2)^x$

18 Copy the table below in your exercise book. Use the graphs you have drawn in exercise 17 to complete the table below.

	Function	Intercept	Domain	Range	Asymptote
(a)	$y = -1(3)^x$				
(b)	$y = -1(4)^x$				
(c)	$y = -1(5)^x$				
(d)	$y = -1(1,25)^x$				
(e)	$y = -2(5)^x$				
(f)	$y = -3(2)^x$				

- 19 How are the graphs of $y = -1(3)^x$ and $g(x) = 3^x$ similar? You may answer this question by considering the following aspects:
- domain
 - range
 - y -intercept
 - horizontal asymptote
- 20 How are the graphs of $y = -1(3)^x$ and $g(x) = 3^x$ different? You may answer this question by considering:
- the direction of each graph
 - which function decreases and which increases

7.6 The hyperbola

The hyperbola functions are functions of the type, $y = \frac{a}{x}$; $x \neq 0$ and $y \neq 0$. Just like we did with the exponential function, we can draw a graph of a hyperbolic function by first completing a table of values and then plotting the points on a Cartesian plane.

A vertical line, parallel to the y -axis, is a **vertical asymptote of a curve** when the distance between coordinate points on the curve and the asymptote line continually decreases but never becomes zero as the y -coordinates of these points move to the right (increase) or move to the left (decrease).

Worked example

Problem: Suppose we want to draw the graph of a function given by $y = \frac{6}{x}$.

Solution: We rewrite this function as $xy = 6$ and then complete a table showing the relationship between the x - and y -values, as shown in the table below. We then plot the points on the Cartesian plane and join them.

x	-6	-3	-2	-1	$-\frac{1}{2}$	$\frac{1}{2}$	1	2	3	6
y	-1	-2	-3	-6	-12	12	6	3	2	1

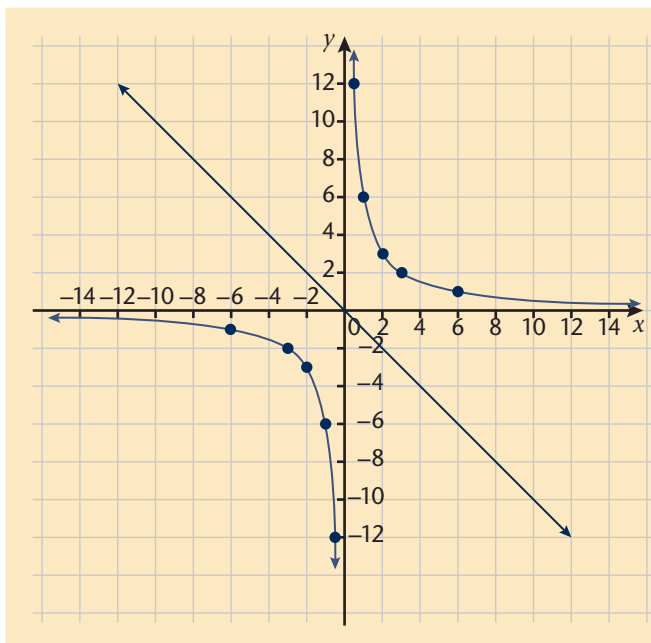

The graph of the hyperbola we have drawn, has the following features:

- (a) Domain of $y = \frac{6}{x}$: $\{x: x \in \mathbb{R}, x \neq 0\}$
- (b) Range of $y = \frac{6}{x}$: $\{y: y \in \mathbb{R}, y \neq 0\}$
- (c) The function has a discontinuity at $x = 0$
- (d) There are two asymptotes:
 1. a horizontal asymptote at $y = 0$
 2. a vertical asymptote at $x = 0$
- (e) The graph has a line of symmetry $y = -x$, which means one half of the hyperbola is a mirror image of the other half.

Exercises The hyperbola

21 Use the table method to draw the graphs of the functions defined below. Use separate axes.

(a) $y = \frac{-12}{x}$

(b) $y = \frac{6}{x}$

(c) $y = \frac{-6}{x}$

(d) $y = \frac{8}{x}$

(e) $y = \frac{-8}{x}$

(f) $y = \frac{-10}{x}$

(g) $y = \frac{16}{x}$

(h) $y = -\frac{20}{x}$

(i) $xy = 1$

22 For each function you drew a graph for in exercise 21, you must write down:

- (a) the domain
- (b) the range
- (c) the equation of the line of symmetry
- (d) the equations of the asymptotes

23 What is the effect of the sign a in $y = \frac{a}{x}$

7.7 Reading from graphs

In this section, we will be reading information from graphs. The graph alongside shows the relationship between the number of grams of a certain type of cereal and the number of calories.

The y -axis represent calories and the x -axis represent the grams.

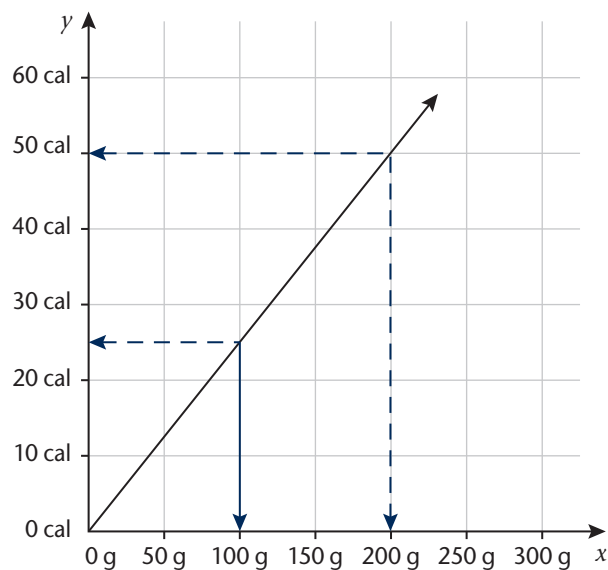

Worked example

Problem: What information is shown on the graph?

Solution:

- From the graph we can see that the amount of calories is given on the vertical axis and the amount of grams is given on the horizontal axis.
- The grams are given in intervals of 50 and the calories in intervals of 10.
- According to the information on the graph, 100 grams of the cereal contains 25 calories, and 200 grams of cereal contains 50 calories.

Exercises

Refer to the graph given in the example to answer the questions below.

- If you have 10 grams of the cereal, how many calories will you consume?
- If you want to consume 35 calories, how many grams of cereal should you eat?
- A graph of a certain quadratic function is given alongside.

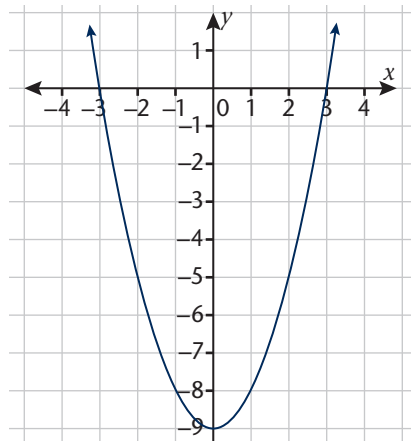

(a) Copy and complete the table below by reading values from the graph.

x											
y											

(b) Write down the coordinates of the turning point by reading from the graph.

27 Some people still use feet as a unit of measurement. We can convert between length in feet (ft) and length in metres. The graph below shows the relationship graphically between metres and feet, with the y -axis representing measurements in feet and the x -axis representing measurements in metres.

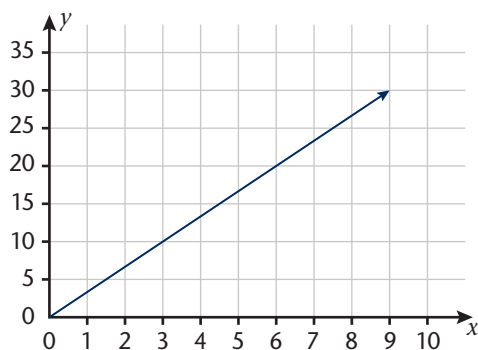

(a) How many feet are equivalent to 9 metres?

(b) The length of a building's foundation is 25 feet. What is the equivalent length in metres?

(c) Which is longer, 6 metres or 15 feet?

7.8 Summary

- The definition of a function consists of the following components:
 - the name of the function
 - the variables that represents a value at which to evaluate the function
 - a rule that says how to calculate the function's output for the given input value
 - the number that results from applying the rule to a specific input value is called an output value and is represented by $f(x)$.
- The **domain** is the set of all possible input values to which the rule applies.
- **Range** is the set of all output values.
- The **intercept** is a point at which the graph intersects the x - or y -axis.
- The **asymptote** is a line that the graph will approach for very large values of one of the variables.

7.9 Consolidation exercises

1 Copy and complete the table below for the function defined by $f(x) = x$

x	-4	-3	-2	-1	0	1	2	3	4
$f(x)$									

- Name the x -intercept.
- Name the y -intercept.
- What is the domain?
- What is the range?

2 Draw the graphs of the following functions.

(i) $f(x) = -x$ (ii) $g(x) = 3x + 4$ (iii) $h(x) = -x + 1$

- For each of the above, give the x -intercept.
- For each of the above, give the y -intercept.
- For each of the above, give the domain.
- For each of the above, give the range.

3 Study the graphs below and write down for which values of x .

(i) $f(x) = 0$ (ii) $f(x) > 0$ (iii) $f(x) \geq 0$

(iv) $f(x) < 0$ (v) $f(x) \leq 0$

(a) $f(x) = x^2 - 4$

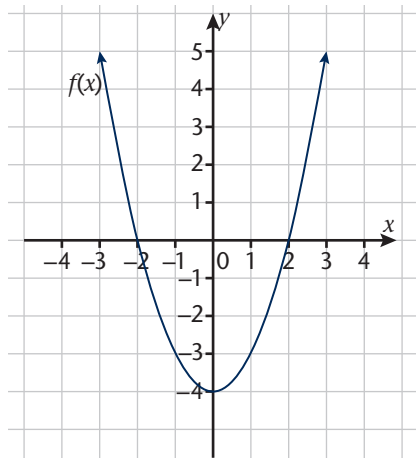

(b) $f(x) = -x^2 + 16$

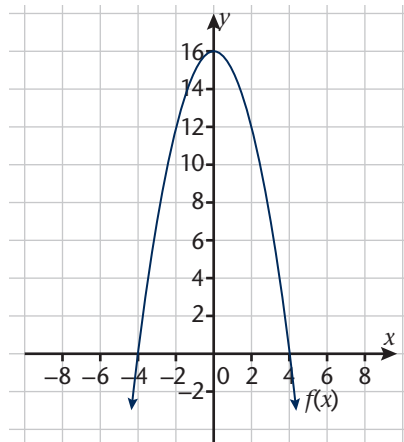

(c) $f(x) = -x^2 - 4$

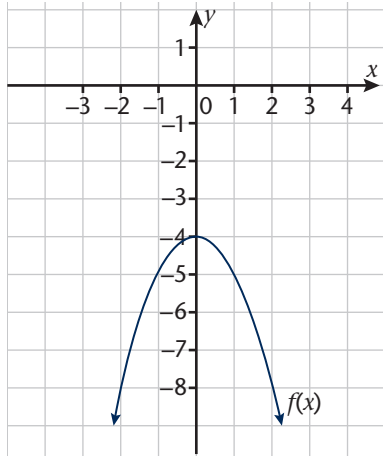

(d) $f(x) = x^2 - 2$

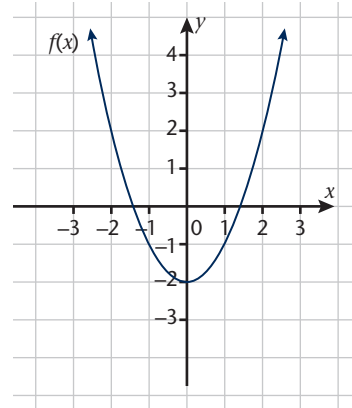

4 Study the following functions and answer the questions that follow:

$$f(x) = -\frac{1}{4}x^2 + 6 \text{ and } g(x) = 4x + 6$$

- (a) Sketch the graphs on the same set of axes.
- (b) Use your graphs to solve for x if:
 - (i) $f(x) \geq 0$
 - (ii) $f(x) = g(x)$
 - (iii) $f(x) < g(x)$
- (c) What is the range of $f(x)$ and $g(x)$?
- (d) What is the domain of the two graphs?

5 Answer the questions on graph $y = -x^2$

- (a) If the point $(-1; y)$ lies on the graph $y = -x^2$, find the value of y in this coordinate.
- (b) What is the domain?
- (c) What is the range?
- (d) Does this graph have a minimum or maximum value? What is this value?
- (e) For which values of x is the graph increasing?
- (f) For which values of x is the graph decreasing?
- (g) Is the graph continuous?

6 Answer the questions on graph $y = x^2$

- (a) If the point $(2; y)$ lies on the graph $y = x^2$, find the value of y in this coordinate.
- (b) What is the domain?
- (c) What is the range?
- (d) Does this graph have a minimum or maximum value? What is this value?
- (e) For which values of x is the graph increasing?
- (f) For which values of x is the graph decreasing?
- (g) Is the graph continuous?

7 What are the turning points of the following graphs?

- (a) $f(x) = x^2 - 2$
- (b) $f(x) = x^2 + 10$
- (c) $f(x) = x^2 + 3$
- (d) $f(x) = x^2 - 4$

8 Draw the graphs on the same set of axes and give the following for each:

- | | | | |
|------------------|------------------|----------------------------|---------------------|
| (i) Intercept | (ii) Domain | (iii) Range | |
| (a) $g(x) = 4^x$ | (b) $t(x) = 8^x$ | (c) $h(x) = \frac{2^x}{3}$ | (d) $p(x) = 1,75^x$ |

9 Consider the functions defined by $y = -\frac{x}{3}$ and $xy = 2$

- (a) Draw the graphs on the same set of axes.
- (b) Write down the domain.
- (c) Write down the range.

10 Rewrite the following functions in terms of $y = \frac{a}{x}$

- (a) $xy = 5$
- (b) $xy = -2$
- (c) $xy = 6$
- (d) $xy = -12$

8 GEOMETRY

This chapter is largely revision of what you have covered in previous grades. It will provide you with a chance to fix up and improve your understandings of geometry. Make sure you pay careful attention to the ideas that are put forward. They may help you clear up any confusion you may have about the basics of geometry.

In this chapter, you will learn about:

- the concept of angles
- angle relationships with parallel lines
- angle relationships with triangles
- the types of triangles and their properties
- similarity and congruence of triangles
- types of quadrilaterals and their properties
- Theorem of Pythagoras

What you need to be able to do in this chapter:

- calculate angles in diagrams using your knowledge of parallel lines, triangles, and quadrilaterals
- to identify parallel lines, types of triangles, and quadrilaterals and their properties, and use these to solve problems
- calculate lengths using your knowledge about triangles (including the Pythagorean Theorem in right-angled triangles) and quadrilaterals
- be able to decide if two triangles are similar or congruent and use this to solve problems

8.1 Revising angles relating to parallel lines

Line terminology

Line segment: this is a straight line that has two ends, e.g. AB below

Ray: this is a straight line with one end only; we imagine the other 'end' continues past *any* point we can choose; we can put an arrow at the end to show this, e.g. MN below

Line: this is a straight line where both 'ends' continue past any points we can choose; we can put arrows at both ends to show that we mean this, e.g. VW below

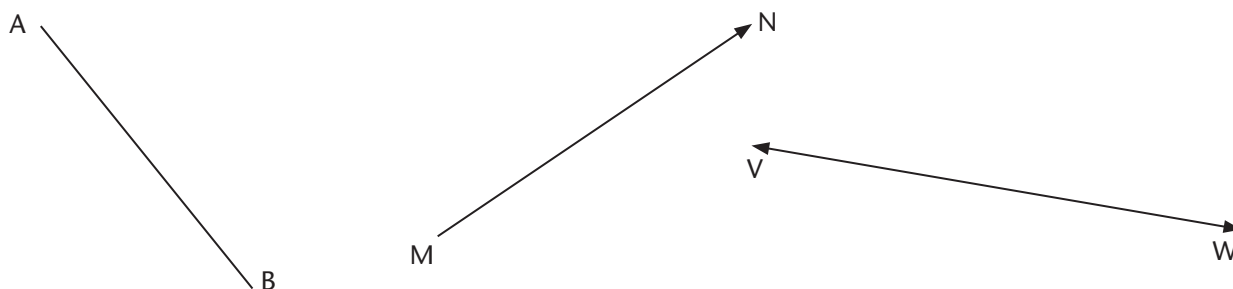

Note: we will follow everyday convention and use the word 'line' to mean any or all of these three, unless we need to be clear about exactly what we mean.

Terminology and properties of angles at a vertex

Shown here are two lines, JM and KL, which intersect at point O, forming four adjacent angles a , b , c , and d :

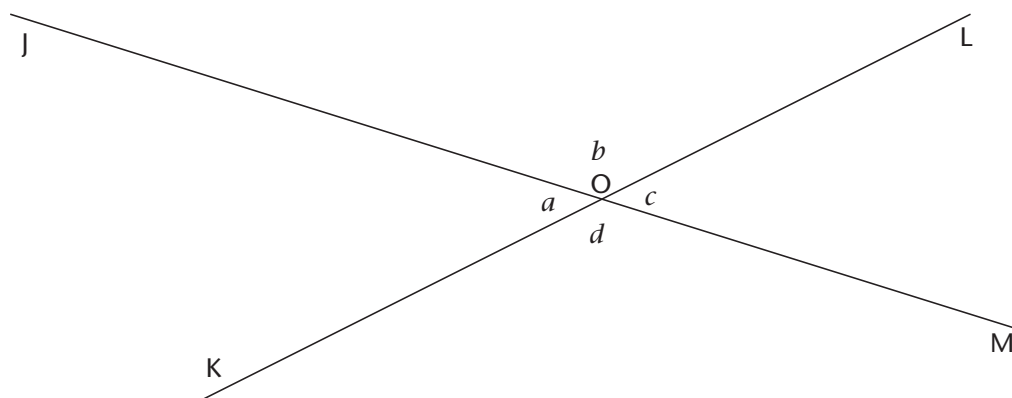

Vertex: where two rays meet or where two lines cross e.g. point O above

Vertically opposite angles: opposite pairs of angles at a vertex are equal, e.g. $\angle a = \angle c$ are vertically opposite and $\angle b = \angle d$ are vertically opposite.

Supplementary angles: angles adding up to 180° , for example angles on a straight line that add up to 180°

Terminology of angles when two lines are cut by a transversal

Here are the two straight lines AB and CD, cut by a transversal, EF:

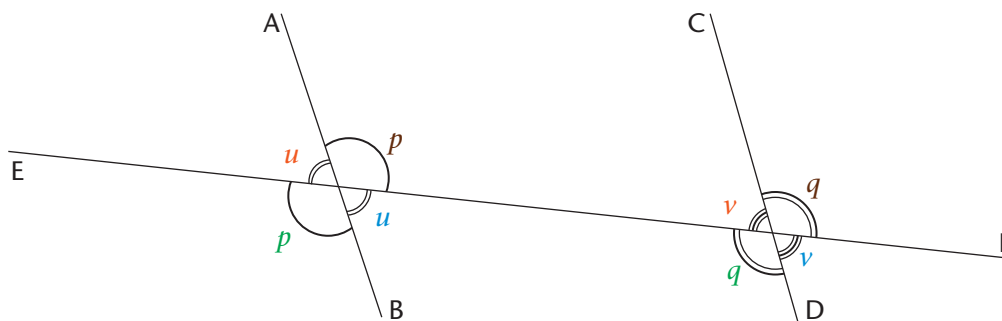

Transversal: any line that cuts across - transverses - two or more lines, e.g. line EF is a transversal of line of AB and CD.

Corresponding angles: a pair of angles in the same positions relative to the transversal; the colour-coded pairs in the diagram are corresponding angles, u and v for example; there are four pairs of corresponding angles.

Co-interior angles: a pair of angles that are co- 'together' -interior 'inside'; there are two pairs of co-interior angles, p and v are co-interior, and u and q are co-interior.

Alternate angles: these are pairs of angles on alternate sides of the transversal and also between the two lines; there are two pairs of alternate angles, p and q are alternate, and u and v are alternate.

Exercises Some basic angle revision

- 1 Two lines FH and JK cut each other at vertex G. One of the angles at vertex G, $\angle G_3 = 38^\circ$.

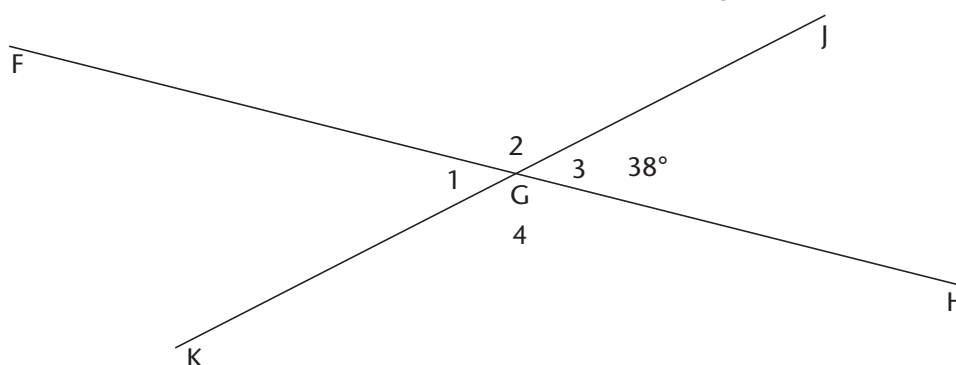

- (a) What are the sizes of the other three angles at the vertex?
- (b) Use the idea of an angle as a measure of rotation, i.e. fraction of a revolution,
- to explain why $\angle G_1 + \angle G_2 = 180^\circ$, and
 - to explain why $\angle G_2 = \angle G_4$.

- 2 Three lines intersect as shown. The eight different angles between the lines are shown with symbols to represent them:

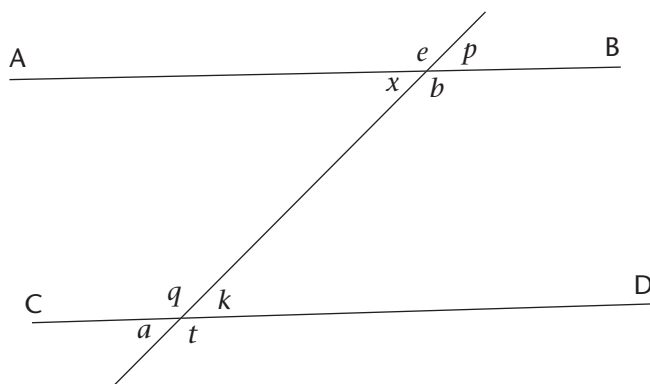

Identify all the possible pairs of:

- alternate angles,
- corresponding angles,
- vertically opposite angles,
- co-interior angles, and
- supplementary angles in the diagram.

Some properties of parallel lines revealed

Exercise Parallel lines

- 3 Cylindrical bearings can be used to move heavy objects smoothly across a flat surface with very little friction:

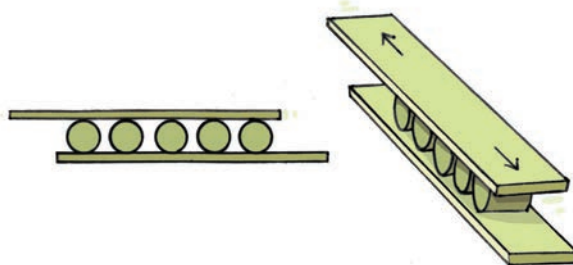

The upper plate in the diagram can roll backwards and forwards on the metal cylinders that act as linear motion bearings. We want the upper plate to remain parallel to the lower plate at all times. (What happens if we don't?)

- What are the requirements for the cylindrical bearings for this to happen?
- Based on (a), write down a fact about lines that are parallel, and lines that are not parallel. (**Hint:** let the diameters of the bearings be your inspiration.)

Something very important about how we use geometry diagrams

When we have a **scale diagram**, we can make angle and length measurements directly on it.

When we have a **sketch diagram**, none of the lengths and angles have been drawn with a fixed scale. So, it is impossible to make measurements on such a diagram.

How to work with the two kinds of sketches

- Scale diagrams: Use direct measurements and any geometry facts you know to determine angles and lengths, and to explain things
- Sketch diagrams: *Only* use geometry facts to calculate angles and lengths, and to explain things. *Don't trust your eyes when you are dealing with a sketch diagram! Trust your understanding only!*

Deepening understandings of parallel lines and non-parallel lines

There are many ways that we can describe two lines that are parallel, or two lines that are not parallel.

The following three exercises are about deepening that understanding. Work through them carefully. There are some ideas here that we will use later in the chapter.

Exercises More ways of understanding parallel lines and non-parallel lines

4 Using circles:

- (a) Draw a line across your page. It must be at least 12 cm long. Mark off four points that are 4 cm apart on your line. Label them P_1 , P_2 , P_3 , and P_4 from left to right.

First think about the following. *Imagine* what will happen:

- Draw a circle of radius 3 cm centred at P_1 . Draw a circle of radius 4 cm, centred at P_2 . Draw two more, of radius 5 cm and 6 cm at P_3 and P_4 respectively.
- Draw a line that touches all the circles from *above*. Call it line a . The line must not cut through the circumferences, only touch them. This line is a **tangent** line to all four circles.
- Draw the other line that touches the circles from *below*. Call it line b .
- What can you say about lines a and b ?

Make a rough sketch of what you think will happen.

When you are satisfied that you know what will happen, construct the circles and lines. Are you seeing what you were thinking?

- (b) Draw another line across your page with points P_1 to P_4 as before.

How will you use the construction in (a) to draw two lines that are parallel and 12 cm apart? First write down your steps and then actually do the construction.

- (c) Use your understandings from Exercise 3 and from (a) and (b) above to write down
- a description of non-parallel lines, and
 - a description of parallel lines.

5 Using transversals and comparing angles:

- (a) Redo the construction in Exercise 4(a). Make all your lines faint, like construction lines, except the two lines a and b .

Draw a transversal t across the lines a and b .

Measure all the angles where t intersects a and where t intersects b .

What can you say about all the pairs of

- corresponding angles?
- alternate angles?
- co-interior angles?

- (b) Repeat what you have done in (a) for the construction in Exercise 4(b).

- (c) Use your understandings from Exercise 3 and from (a) and (b) above to write down

- a description of non-parallel lines, and
- a description of parallel lines.

6 Using two parallel transversals and comparing lengths:

- (a) Redo the construction in Exercise 4(a). Make all your lines faint, like construction lines, except the two lines a and b .

Draw a transversal t across the lines a and b .

Use the following method to draw another transversal parallel to t .

Call this transversal p .

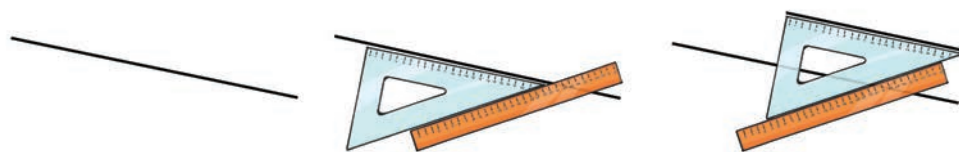

Your diagram should look something like this:

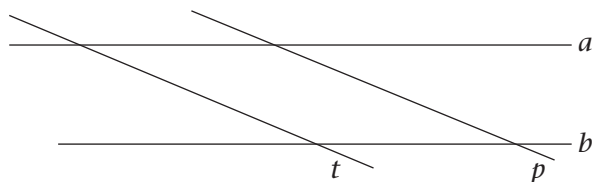

Measure the length of the segment of t that lies between lines a and b . Do the same for transversal p .

What can you say about the lengths of the two segments of the parallel transversals when a and b are not parallel?

- (b) Repeat what you have done in (a), but for the construction in Exercise 4(b).

What can you say about the lengths of the two segments of the parallel transversals when a and b are parallel?

What can we learn from Exercise 3 to 6?

We can be clear about what parallel lines are. There are many ways to define parallel lines.

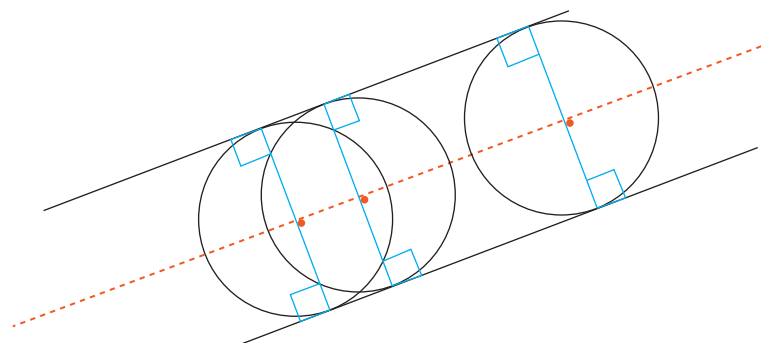

The circles are all of equal diameter (diameters shown in blue, perpendicular to the two parallel lines) and their centres lie along the same line (the dashed red line).

Important ways of describing and defining parallel lines

- if you draw a single transversal through a pair of parallel lines, the pairs of corresponding angles will be equal, as indicated with the four pairs of colour-coded angles shown here:
- if you draw a single transversal through a pair of parallel lines, the pairs of alternate angles will be equal. As indicated here:

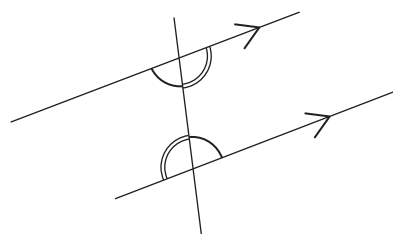
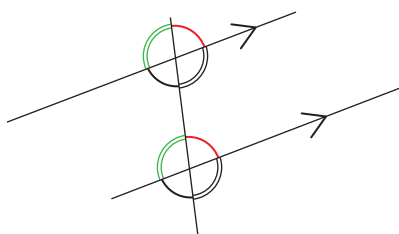

- if you draw a single transversal through a pair of parallel lines, the pairs of co-interior angles will be supplementary, i.e. add up to 180° , as in the red pair and green pair of angles here:
- if you draw a pair of parallel transversals through a pair of parallel lines, the opposite line segments between the four vertices will have the same length, as is the case with the two pairs of colour-coded segments shown here:

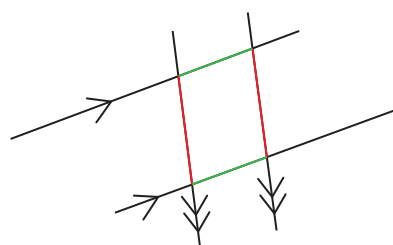
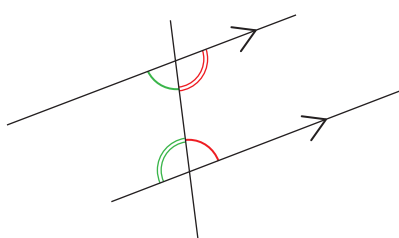

Parallel lines are lines that are a constant distance from each other. Parallel lines never meet, no matter how far you draw them, i.e. if you extend a pair of parallel line segments, they will never intersect, no matter how much longer you extend them.

Looking a little ahead: What kind of geometrical figure is shown in the last diagram?

Some Standard Constructions

Examples Constructing a line parallel to another line

Approach 1: Given a line and a point off the line; using a ruler and Set Square

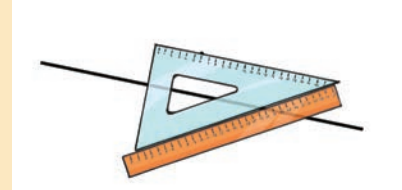
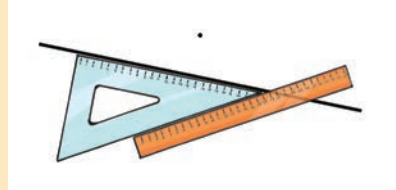
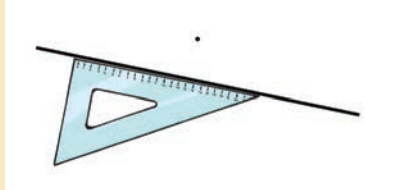

Approach 2: Given a line and a point off the line; using a ruler and pair of compasses

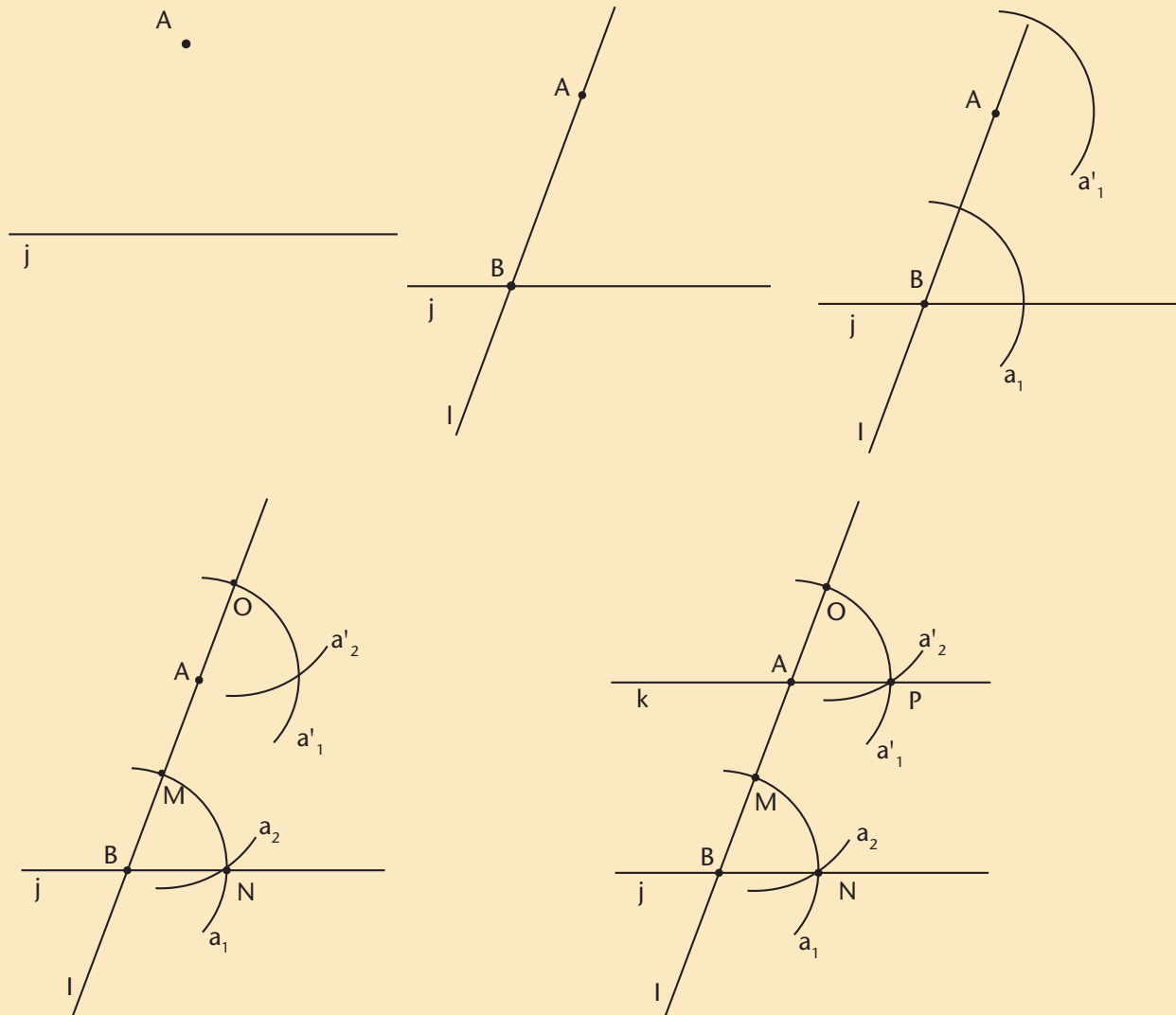

Approach 3: Drawing a line parallel to a given line at a certain distance, using a ruler and pair of compasses: The steps are almost the same as in Exercise 4(b):

- set your compass to the required distance
- draw circles with their centres along the line
- use your ruler and draw one or both of the lines that touch the circles at their circumferences (these are actually tangent lines)

This way is not very accurate and is a bit messy.

It is difficult to judge where to draw the line that touches all the circles – it is a tangent line – and you have to draw many circles to be sure you are more-or-less correct. Here is another way that is a bit more accurate and quicker:

Approach 4: Drawing a line parallel to a given line at a certain distance using a ruler and pair of compasses (another way):

- the steps here should be familiar to you.
- choose any point on the line, A
- construct a perpendicular line through the point A
- measure the separation distance on this line from A to B
- construct a line through B perpendicular to AB

Exercise

- 7 Practise each of the above constructions until you are satisfied that you grasp and remember them.

8.2 Revising angles relating to triangles

Terminology

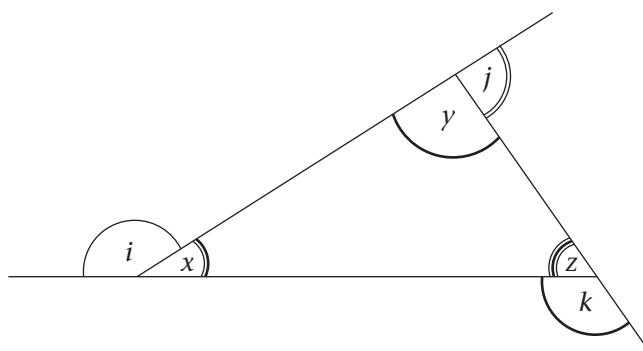

Interior angles: The interior angles of a triangle always add up to 180° , e.g. $\angle x$, $\angle y$, and $\angle z$ in the above triangle.

When we speak of ‘the angles of a triangle’ we conventionally mean the interior angles.

An Exterior angle of a triangle is equal to the sum of the two opposite interior angles of the triangle, e.g. $\angle i = \angle y + \angle z$. The exterior angles of a polygon add up to 360° .

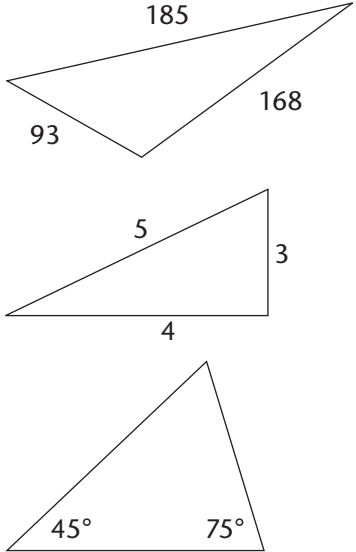
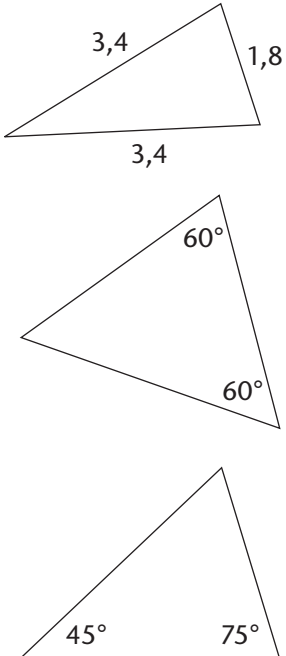
Triangles that are special because of their interior angles and the length of their sides		
<p>Scalene triangle</p>	<ul style="list-style-type: none"> • Interior angles of different values • Sides always of different lengths 	 <p>Three scalene triangles are shown. The first has sides 185, 168, and 93. The second has sides 5, 4, and 3. The third has interior angles of 45° and 75°.</p>
<p>Acute-angled triangle</p>	<ul style="list-style-type: none"> • All three interior angles are smaller than 90° 	 <p>Three acute-angled triangles are shown. The first has sides 3,4, 1,8, and 3,4. The second has interior angles of 60° and 60°. The third has interior angles of 45° and 75°.</p>

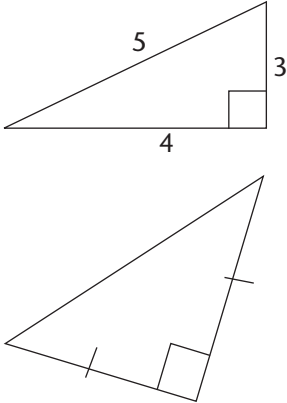
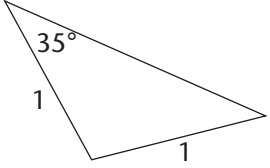
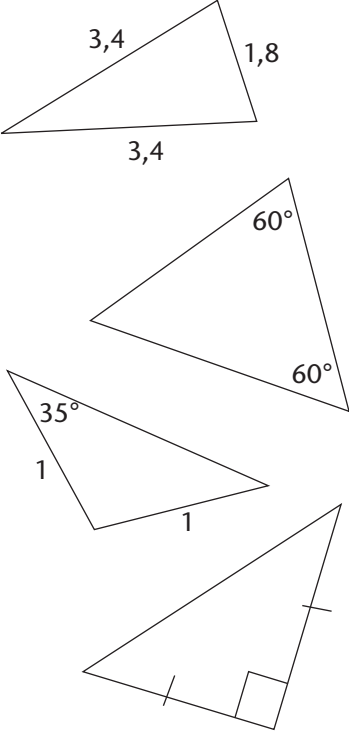
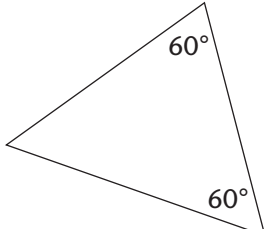
Triangles that are special because of their interior angles and the length of their sides		
<p>Right-angled triangle</p>	<ul style="list-style-type: none"> • One of the angles is 90° • Both remaining angles are automatically acute angles (why?) • Sides have a special mathematical relationship; The Pythagorean Theorem: $\text{hypotenuse}^2 = (\text{side}_1^2) + (\text{side}_2^2)$ • The side opposite the right angle is called the hypotenuse and it is the longest side of the triangle 	
<p>Obtuse-angled triangle</p>	<ul style="list-style-type: none"> • One of the angles is bigger than 90° • Both the remaining angles are acute angles (why?) 	
<p>Isosceles triangle</p>	<ul style="list-style-type: none"> • Two of the angles are equal • These equal angles have to be acute (why?) • Sides opposite the two equal angles are also always equal • Two equal sides • The interior angles opposite these two equal sides are also always equal 	
<p>Equiangular triangle</p>	<ul style="list-style-type: none"> • All three angles are the same and equal to $180^\circ \div 3 = 60^\circ$ • Also called an equilateral triangle because all three sides have the same length 	

Exercises The family of triangles and important properties of triangles

- 8 Give examples of the following triangles. Draw a *scale drawing* of each kind on dotted paper provided by your teacher. You are free to choose the angle sizes and side lengths so long as the triangle is as described.
- (a) a right-angled scalene triangle
 - (b) an obtuse-angled isosceles triangle
 - (c) a right-angled triangle with two obtuse angles
 - (d) an equiangular triangle with one side of length 5 cm
 - (e) an acute-angled triangle that is also isosceles
 - (f) an isosceles right-angled triangle
 - (g) a scalene obtuse-angled triangle
 - (h) a triangle that has its sides in the ratio 1:2:3
 - (i) an isosceles triangle with two angles bigger than the third angle

Note: dotted paper is just a grid of dots that are equally spaced along the two main directions on a sheet of A4 paper. See the chapter Addendum for how to use it.

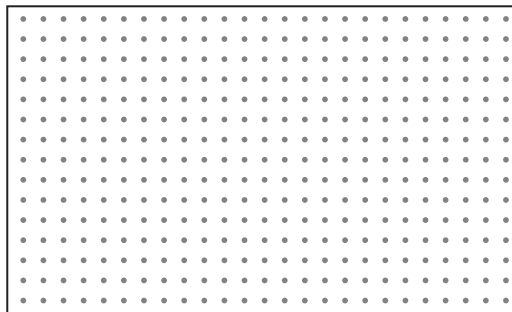

If for some reason, you cannot access dotted paper, you will have to construct your triangles with a ruler and compass.

- 9 The following claim is made by a learner: *'The longest side of a triangle is always opposite the biggest interior angle.'*
- (a) Do you agree with this? Check if this is true by drawing three or more triangles that look very different from each other. You should not have to measure anything unless one of your triangles is close to being equilateral or, equivalently, equiangular.
 - (b) Another learner then asks this question: *'So does that mean that the biggest angle is always opposite the longest side?'* What do you think?
 - (c) Check that the following makes sense: *'In any triangle with three different side lengths, the longest side and biggest angle are opposite each other, the shortest side and smallest angle are opposite each other.'*
 - (d) What can you say about the side of a triangle that has a length that is between the lengths of the longest and shortest sides?

Pulling the geometry of parallel lines and triangles together

Worked example Reasoning geometrically

Problem: Determine the angle θ in the diagram below:

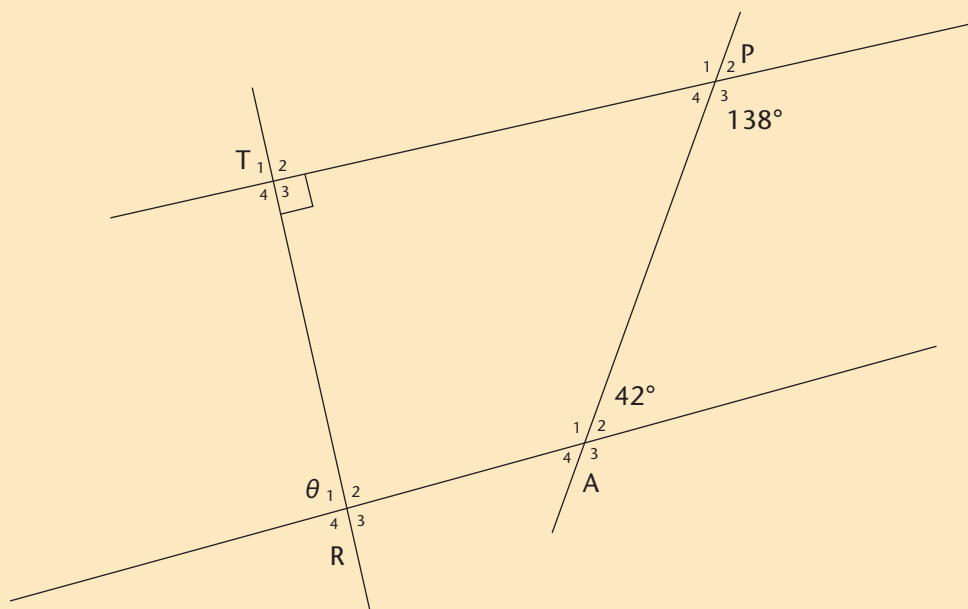

Solution: Study the diagram carefully to see if you notice anything special. There is very little given information, so begin by investigating that. Note that the given co-interior angles are supplementary.

$$\begin{aligned}\text{Step 1: } \angle P_3 + \angle A_2 \\ &= 138^\circ + 42^\circ \\ &= 180^\circ\end{aligned}$$

This means that:

$$PT \parallel AR$$

[co-interior angles are supplementary]

$$\text{Step 2: } \angle R_1 = \angle T_3$$

[alternate angles between parallel lines are equal]

$$\text{So: } \theta = 90^\circ$$

Looking a little ahead: What kind of geometrical figure is TRAP?

Worked example Algebraic equations from geometrical relationships

Problem: In the sketch IQ is a straight line. Determine the following:

- (a) the value of α , and
(b) the value of x

given that: $\angle IUE = 133^\circ$

$$\angle E = 2\alpha - 4$$

$$\angle Q = \alpha + 2$$

$$EU = 2,5 + x \text{ and}$$

$$EQ = 7,5 - 3x$$

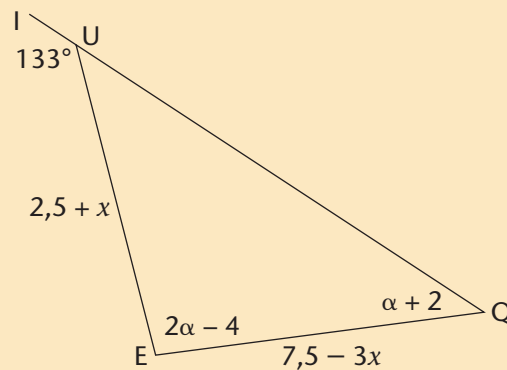

Solution:

- (a) $\angle E + \angle Q = \angle IUE$ [exterior angle of triangle = sum of opposite interior angles]

$$\text{So: } (2\alpha - 4) + (\alpha + 2) = 133^\circ$$

$$3\alpha - 2 = 133^\circ$$

$$3\alpha = 135^\circ$$

$$\text{Therefore: } \alpha = 45^\circ$$

$$\angle Q = \alpha + 2 = (45^\circ) + 2 = 47^\circ$$

$$\angle QUE = 180^\circ - \angle IUE = 180^\circ - 133^\circ = 47^\circ \quad [\text{angles on straight line are supplementary}]$$

$$EU = EQ \quad [\triangle QUE \text{ is isosceles}]$$

$$\text{Therefore: } 2,5 + x = 7,5 - 3x$$

$$4x = 10$$

$$x = 2,5 \text{ units}$$

Exercises

Note: Provide a reason for any statement.

10 Calculate the value of x , y , and z in the following figures.

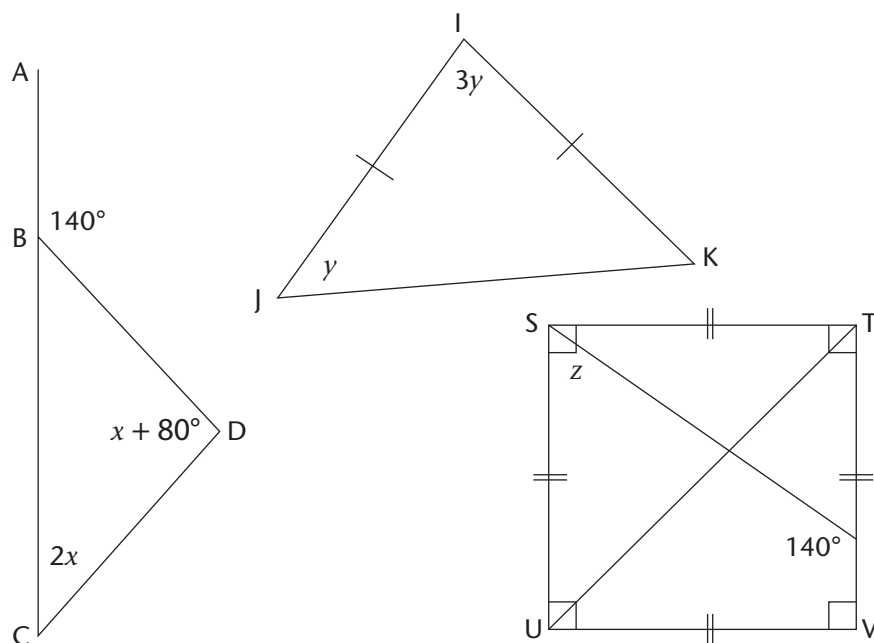

11 Calculate the missing angles in the following diagram.

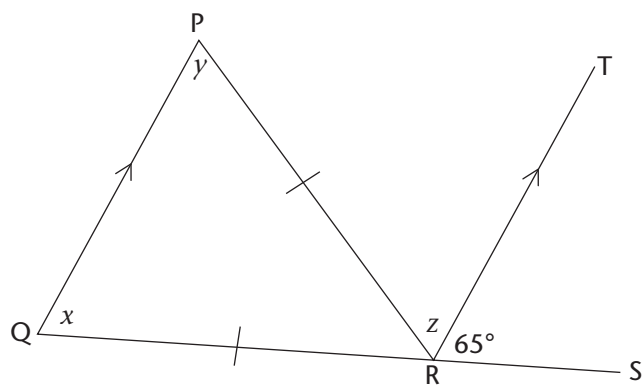

12 Determine each of the angles a , b , c , d , and e in the following diagram.

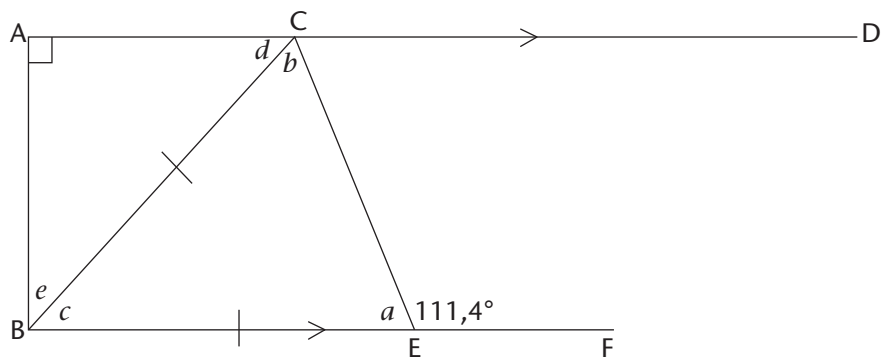

13 Find the unknown angles in the following diagrams:

(a) In the diagram, $AB = BC$ and $AB \parallel CE$

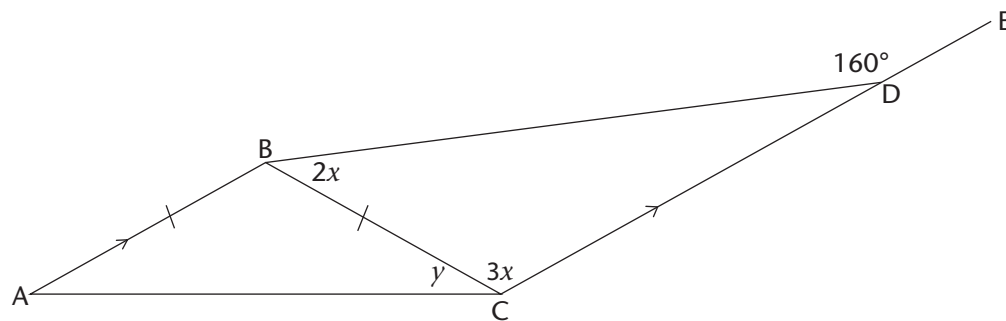

(b) In the diagram, $ST \parallel KN$:

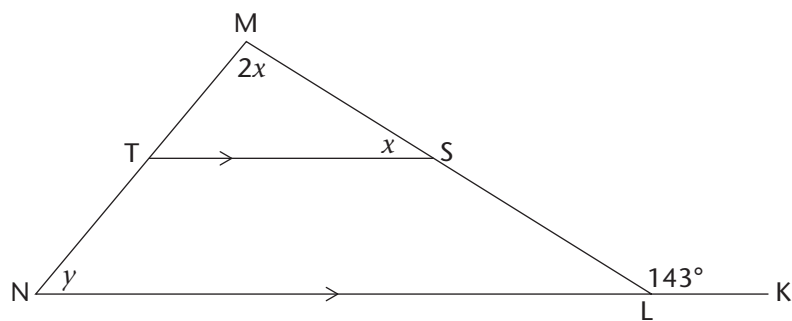

14 (a) Determine the unknown angles a , b , c , d , e , and f in the following diagrams:

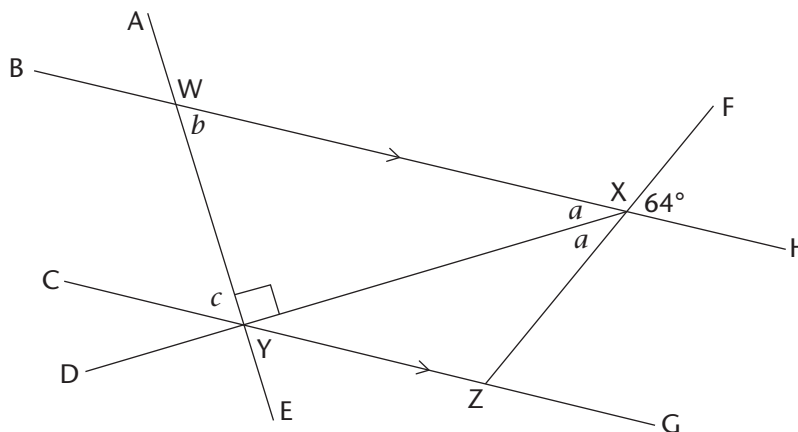

(b)

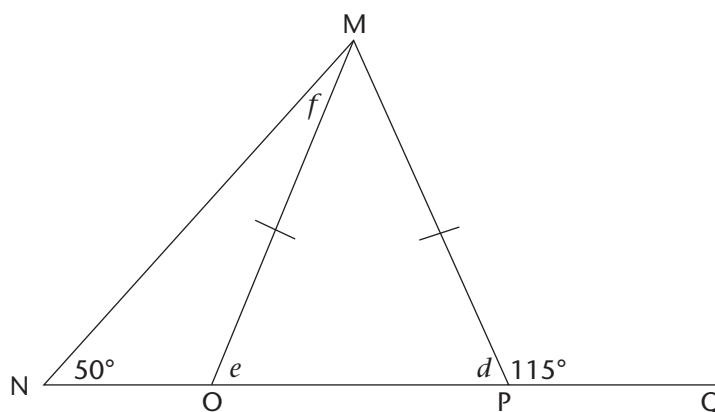

15 Say whether the following are true or false (if false, correct the statement).

- All acute-angled triangles are scalene triangles.
- Some equiangular triangles are not equilateral.
- The shortest side of a triangle is opposite the largest angle.
- Some triangles have two obtuse angles.
- An equilateral triangle is always isosceles.

8.3 Congruence of triangles

Exercises Investigating congruence

- 16 Is there something that is the same about the six triangles below? Describe in words what you observe to be the same. Start your description with the words 'In each of the triangles ...'

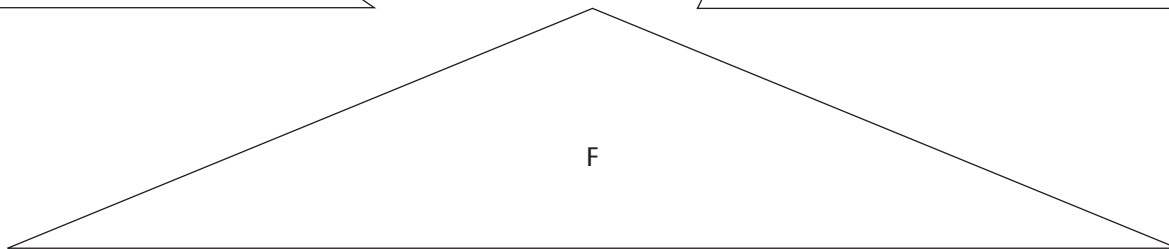
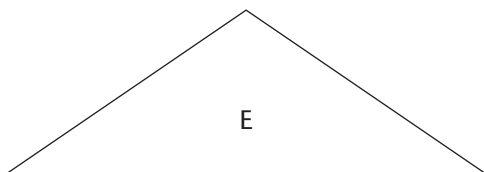
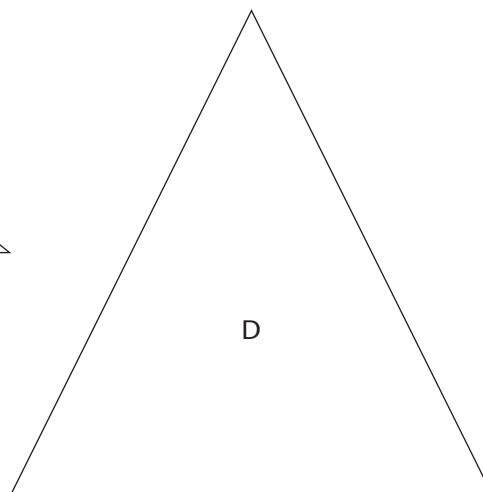
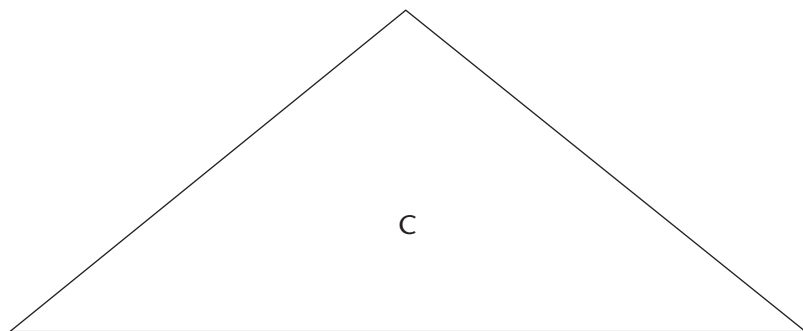
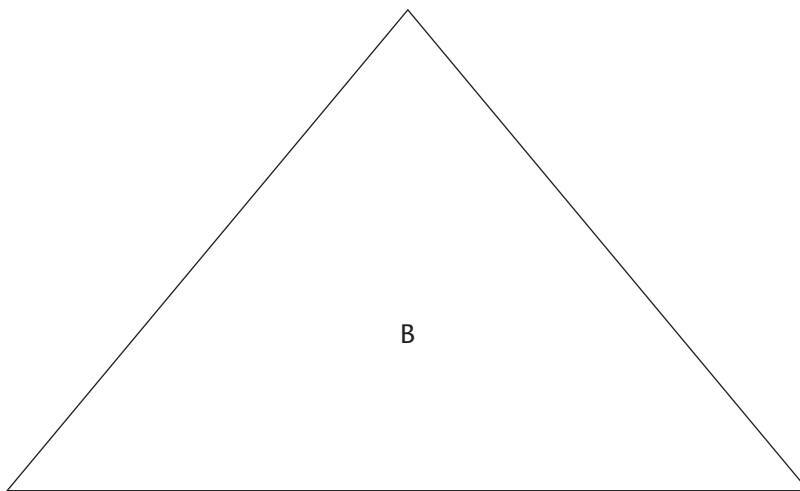
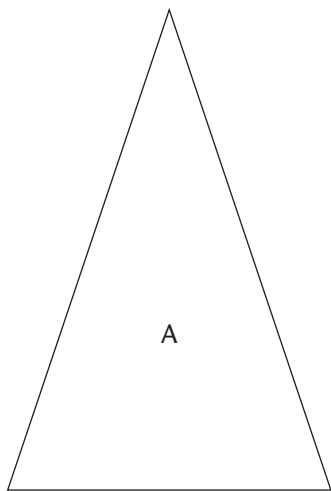

17 Are the five triangles below and on the next page all the same, or are there differences between them?

- (a) Use your ruler and protractor to measure all the sides and all the angles of each of the five triangles below. Write down the results of your measurements of the triangles in your exercise book.
- (b) Which properties are the same in the five triangles?

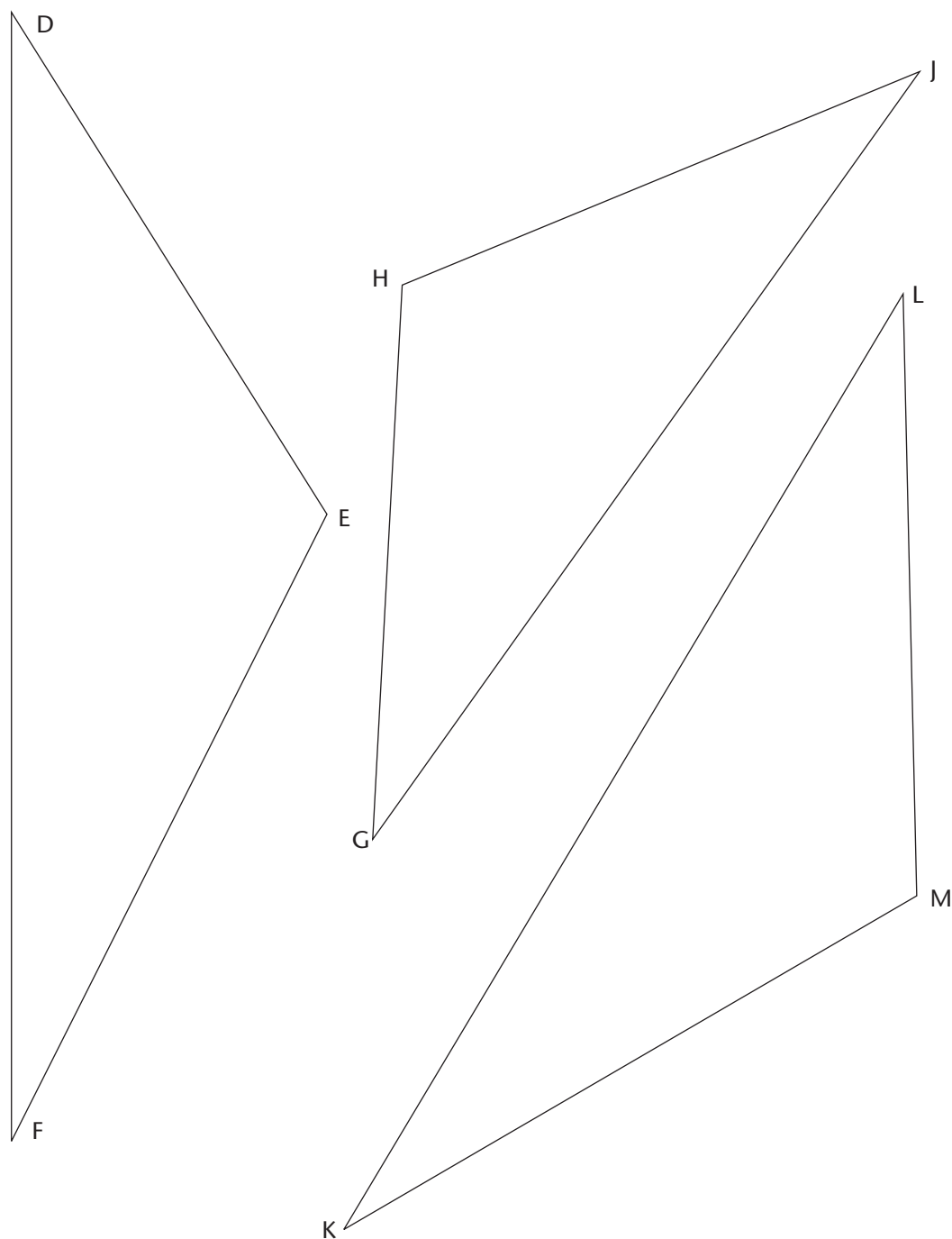

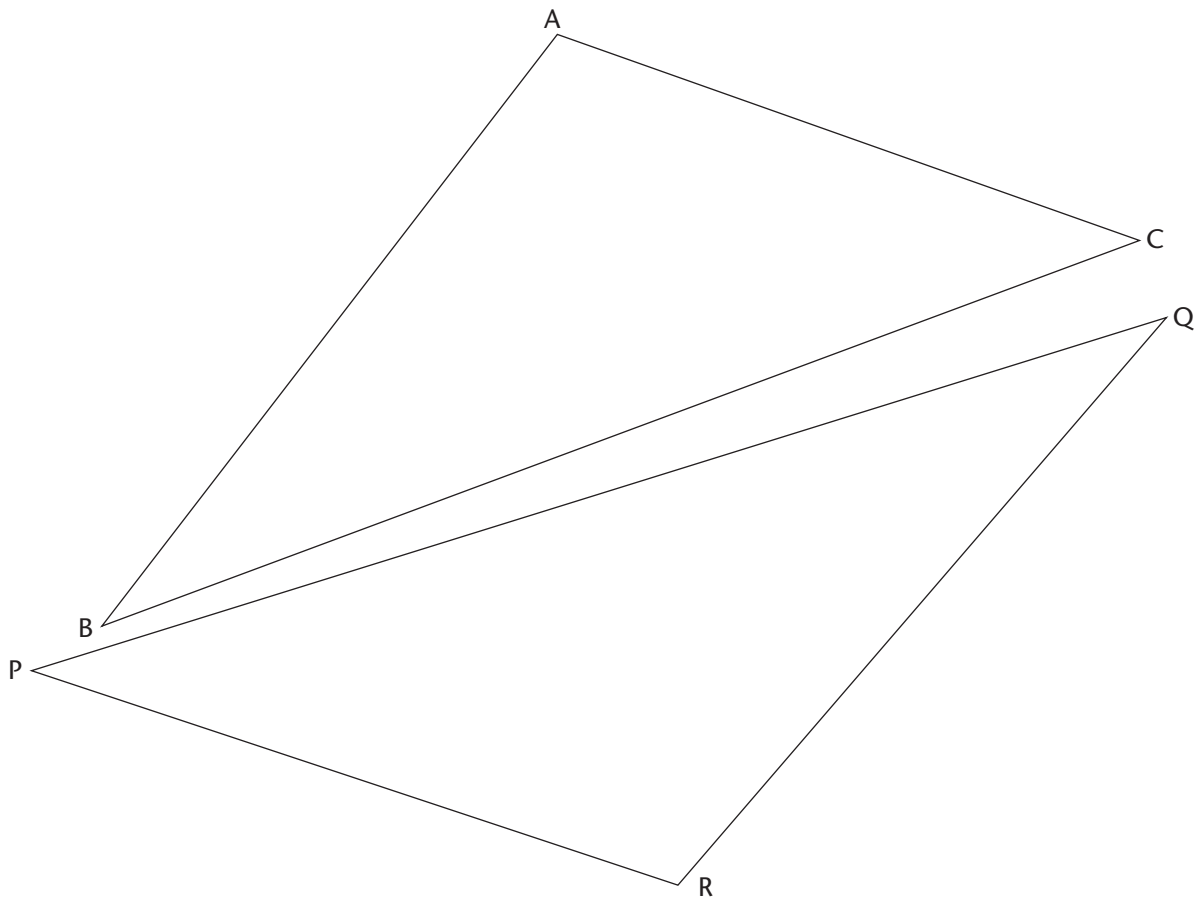

- 18 Are the five triangles below and on the next page all the same, or are there differences between them?
- Use your ruler and protractor to measure all the sides and all the angles of each of the triangles below and on the next page. Write down the results of your measurements of the triangles in your exercise book.
 - Which properties are the same in the five triangles?

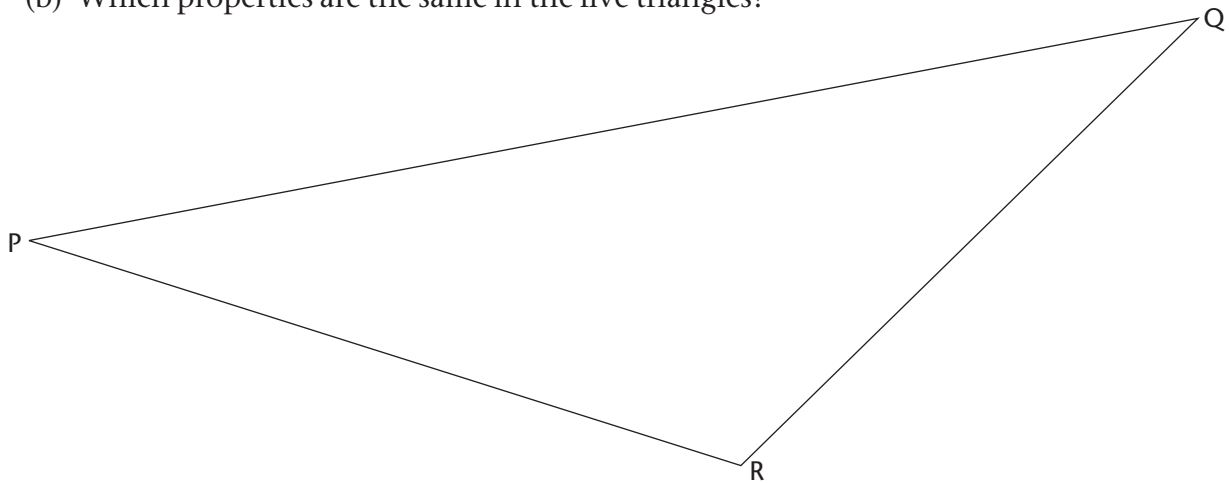

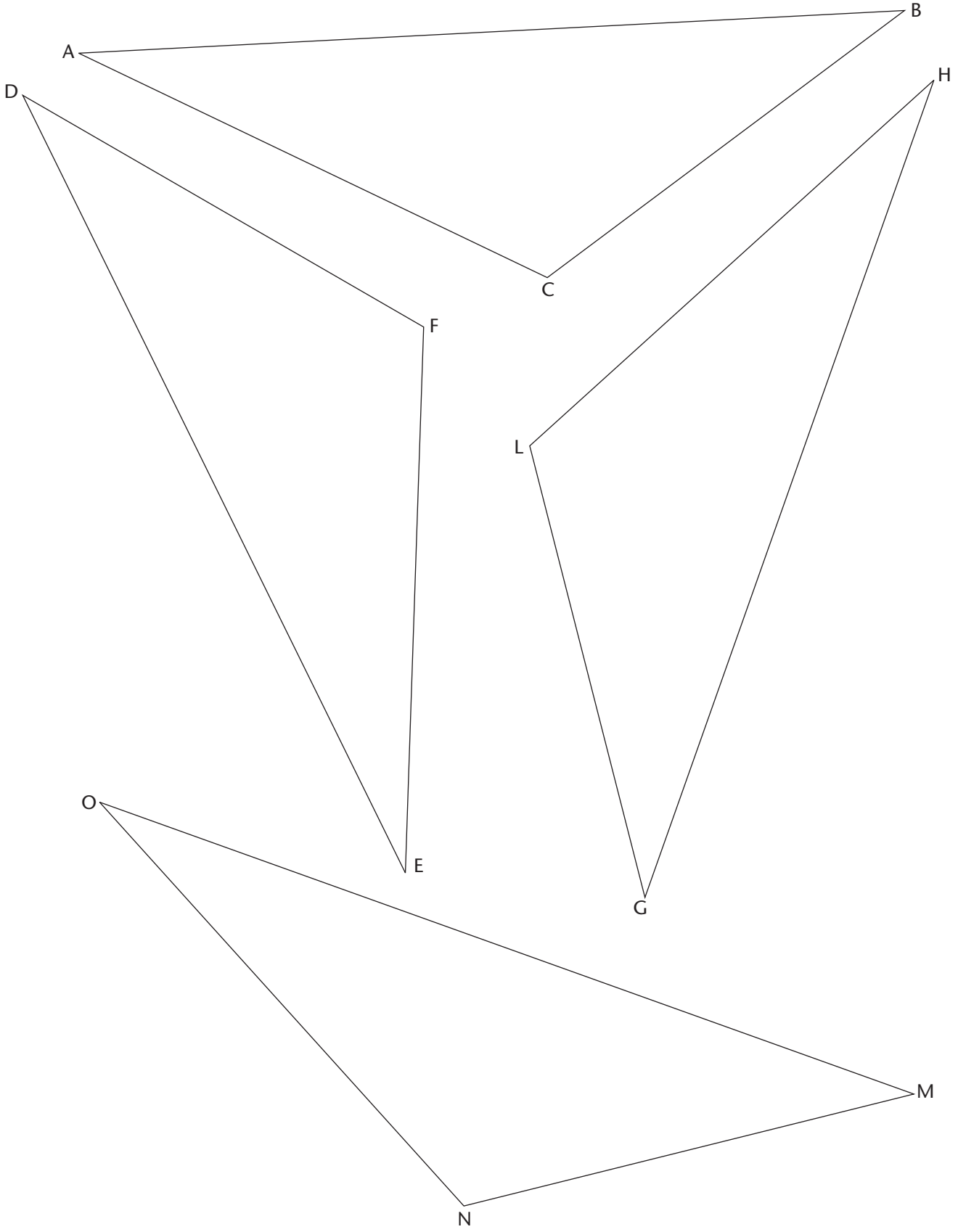

Triangles that are the same in all respects, like the five triangles on the previous two pages, are called **congruent triangles**. The word 'congruent' means 'the same'.

- 19 (a) What are the sizes of the third angles in the following two triangles?
- $\triangle ABC$ with $BC = 12$ cm, $\angle B = 80^\circ$ and $\angle C = 40^\circ$.
 - $\triangle PQR$ with $PQ = 12$ cm, $\angle P = 80^\circ$ and $\angle Q = 60^\circ$
- (b) Do you think the above two triangles are congruent? Make drawings and measurements to investigate this.

20 Draw triangles accurately:

- (a) Draw an exact copy of $\triangle ABC$. All the measurements, angle sizes, and lengths of sides, on your $\triangle A'B'C'$ must be exactly the same as the corresponding measurements on ABC .

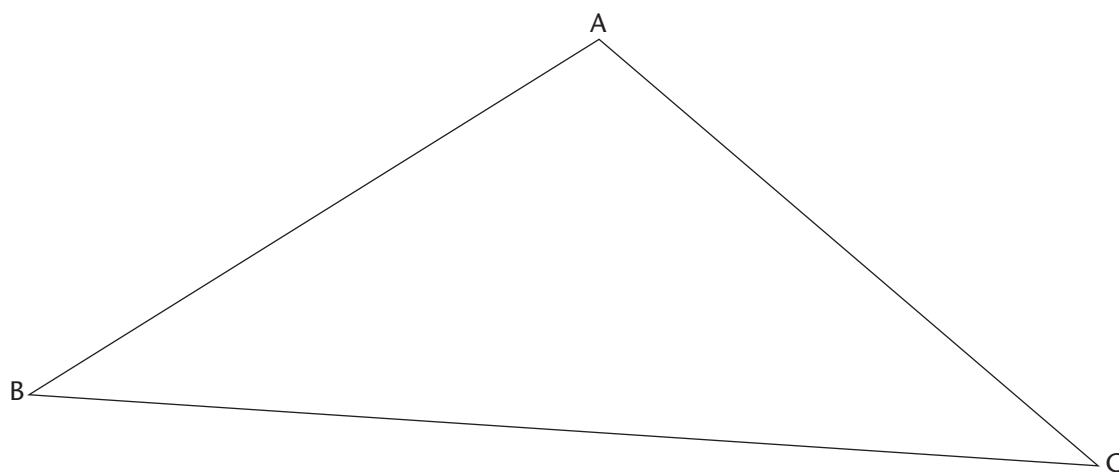

- (b) Describe any unexpected or interesting experiences you may have had while drawing the $\triangle A'B'C'$.

21 The line segment PQ is given:

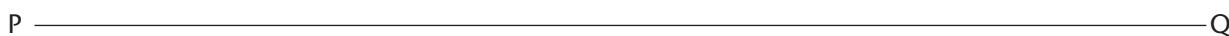

- (a) Redraw the line segment PQ shown above. Mark 10 different points that are all 10 cm away from the left end P of the line segment PQ above. Use your compasses to make the task easier. Mark some of the points above PQ and some below the line. Also mark 10 different points that are all 8 cm away from the right end Q of the line segment PQ.
- (b) Find and mark point X that is exactly 10 cm away from P and 8 cm away from Q. Mark another point Y that is also exactly 10 cm away from P and 8 cm away from Q.

What have we learned about congruent triangles?

When two triangles are congruent they are identical in every way:

- all three corresponding pairs of angles are equal
- lengths of all three corresponding sides are equal

The equal sides and angles must be in corresponding positions – same relative positions.

How to decide if two triangles are congruent

Term	Definition	Diagram
angle-angle-side [AAS]	Show that two corresponding angles are the same, and one corresponding side is the same	
side-included angle-side [SAS]	Show that two corresponding sides are equal, and the corresponding angle between these sides are equal	
side-side-side [SSS]	Show that all three corresponding sides are equal	
90°-hypotenuse-side [RHS]	For two right-angled triangles, show that the hypotenuses are equal and that a pair of corresponding sides are equal	

Note: that congruent triangles are automatically similar, in the ratio 1:1.

Notation

We use the symbol \equiv as shorthand for 'is congruent to', e.g. writing $\triangle XYZ \equiv \triangle MNO$ is a short way of writing ' $\triangle XYZ$ is congruent to $\triangle MNO$ '.

Worked Example

Problem: State if the following pairs of triangles are congruent or not, based only on the information provided on the diagrams:

Pair 1:

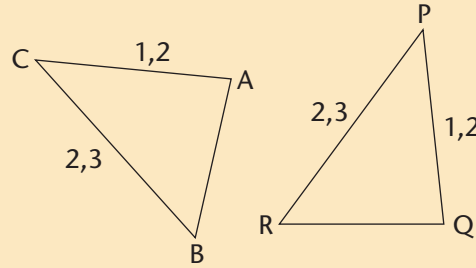

Pair 2:

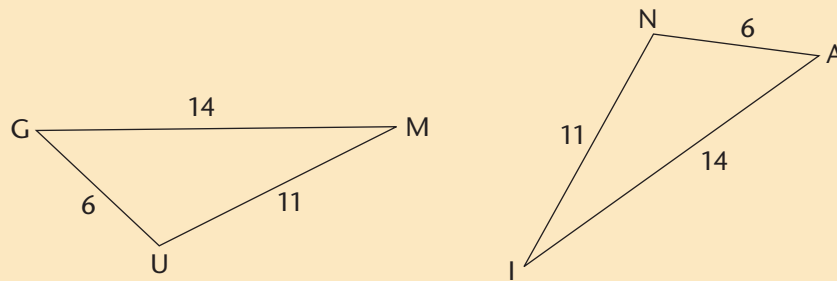

Solution:

Pair 1: triangles are not congruent.

Two corresponding pairs of sides are equal: $AC = PQ$ and $BC = PR$. However, we do not have information about the lengths of AB and QR . They may *look* equal, but we are not dealing with scale diagrams, so we have to assume they are not.

Pair 2: triangles are congruent:

In $\triangle GUM$ and $\triangle ANI$:

- | | | |
|--------------|---|---------------------|
| 1. $GU = AN$ | } | [given information] |
| 2. $UM = NI$ | | |
| 3. $GM = AI$ | | |

Therefore, $\triangle GUM \equiv \triangle ANI$ [S; S; S]

Note that we always assume that the diagrams we are given are sketch diagrams. This means that even if we measure sides AB and QR in Pair 1, we cannot use that. If it is said that the diagrams are to scale, as was done in exercises 21 onwards, then we may take measurements directly on them.

Worked Example

Problem: State if the following pairs of triangles are congruent or not:

Pair 3:

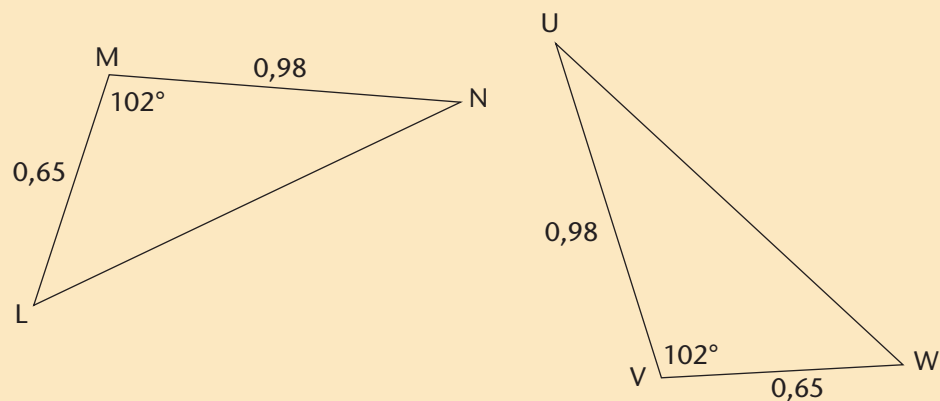

Pair 4:

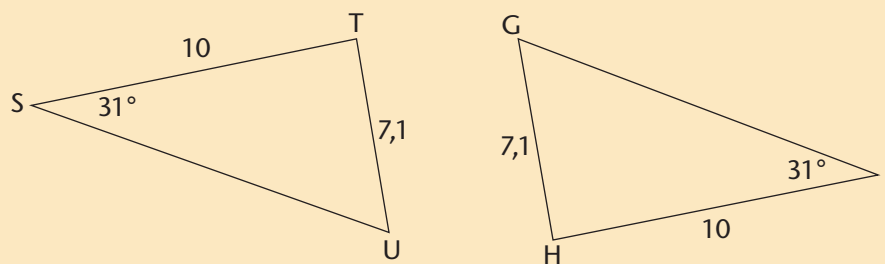

Solution:

Pair 3: The triangles are congruent because $\angle M$ and $\angle V$ are included angles:

In $\triangle LMN$ and $\triangle WVU$:

1. $LM = WV$
 2. $\angle M = \angle V$
 3. $MN = VU$
- } [given information]

Therefore, $\triangle LMN \equiv \triangle WVU$ [SAS]

Pair 4: The triangles are not congruent because $\angle S$ and $\angle I$ are not *included angles*.

The angle be included for [SAS]

The only way that two triangles, with two sides and one angle in common, can be congruent is if:

- the two sides are the arms of the angle; in other words, the equal angle must be ‘included’ between the two equal sides.
- or if the angle happens to be a right angle, the [90° HS]

Worked example Using congruence

Problem: In $\triangle DEF$, $EF = 13$ mm. DX is perpendicular to EF and $\angle FDX = \angle EDX = 40^\circ$. Determine the length of FX .

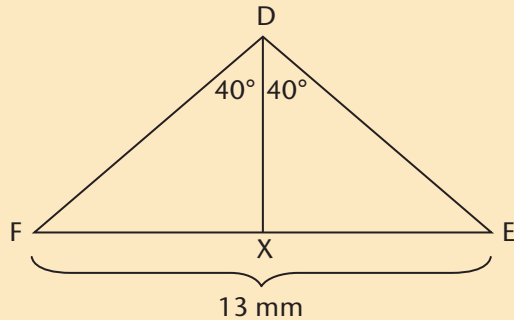

Solution:

In $\triangle DFX$ and $\triangle DEX$:

1. $\angle FDX = \angle EDX$ [given information]
2. $\angle FXD = \angle EXD$ [$DX \perp EF$]
3. DX is common to both triangles
 $\therefore \triangle DFX \equiv \triangle DEX$ [AAS]
 $FX = XE$ [\triangle 's congruent]
 $FX = 13 \div 2 = 6,5$ mm

A word on giving reasons in geometry

In the above examples, each claim or important statement is backed up by a reason, shown in square brackets '[...]'. It is important that each time you make an important step in a geometry problem that you give a reason for why that step is correct. *You may put your reasons in your own words.* If you cannot think of a reason, what you are claiming is probably not true!

Exercises Practise seeing and using congruence in triangles

22 Determine with reasons, whether the following pairs of triangles are congruent or not.

(a)

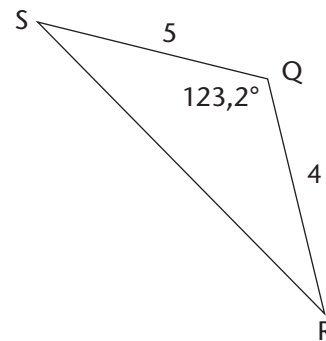
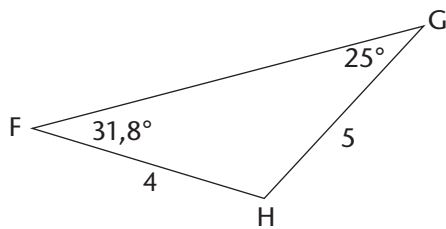

(b)

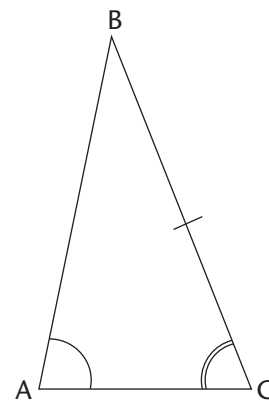
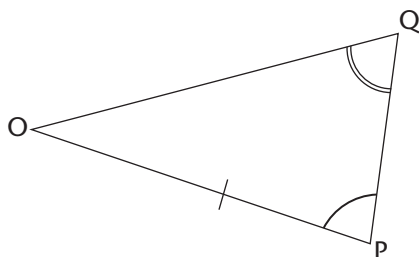

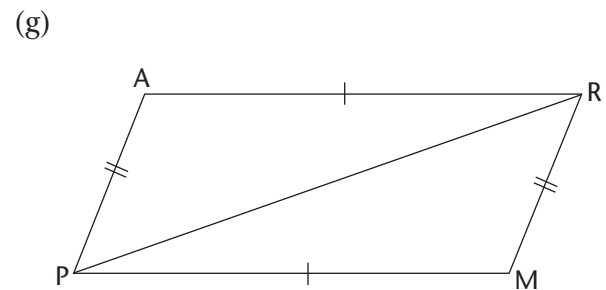
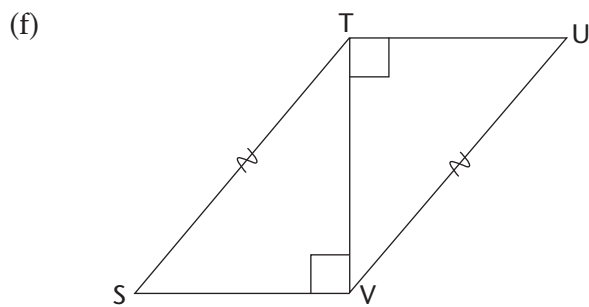
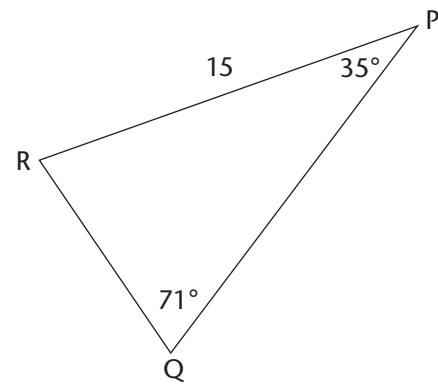
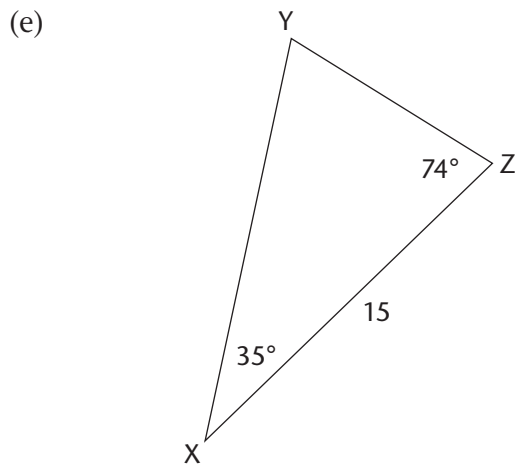
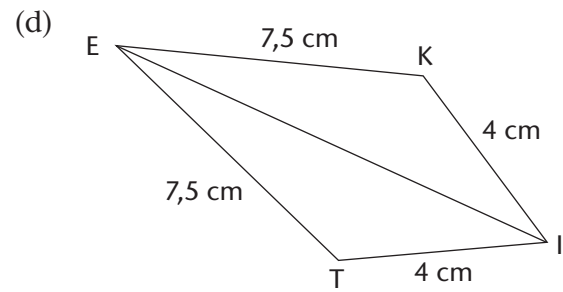
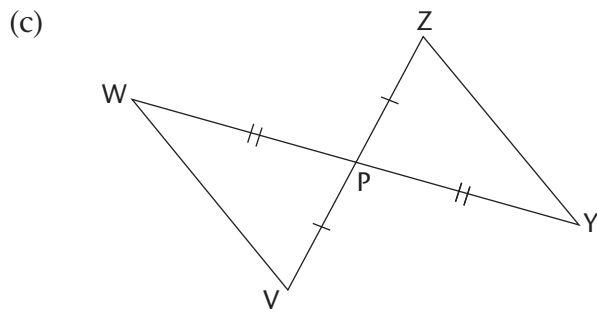

23 $\triangle ABC$ and $\triangle PQR$ overlap as shown in the diagram. $AB \parallel PQ$, $BC \parallel QR$, and $APCR$ is a straight line. Also, AP is the same length as CR . $\angle BAC = 37^\circ$ and $\angle ABC = 105^\circ$.

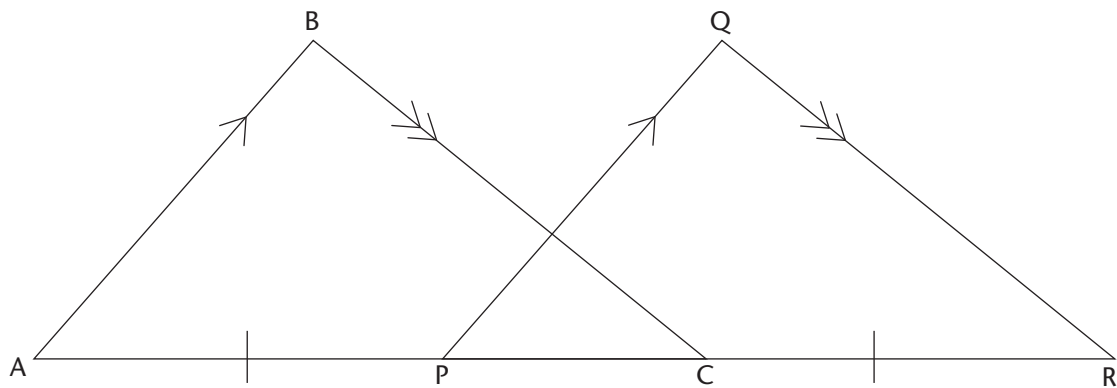

- (a) Determine the sizes, with reasons, of the following angles:
 $\angle BCA$, $\angle QPR$, $\angle PQR$, and $\angle QRP$
- (b) Explain why $AC = PR$.
- (c) Are $\triangle ABC$ and $\triangle PQR$ congruent? Explain your reasoning.

- 24 Thales of Miletus is supposed to have discovered the [AAS] condition for congruency by trying to measure the distance to a ship from the shore:

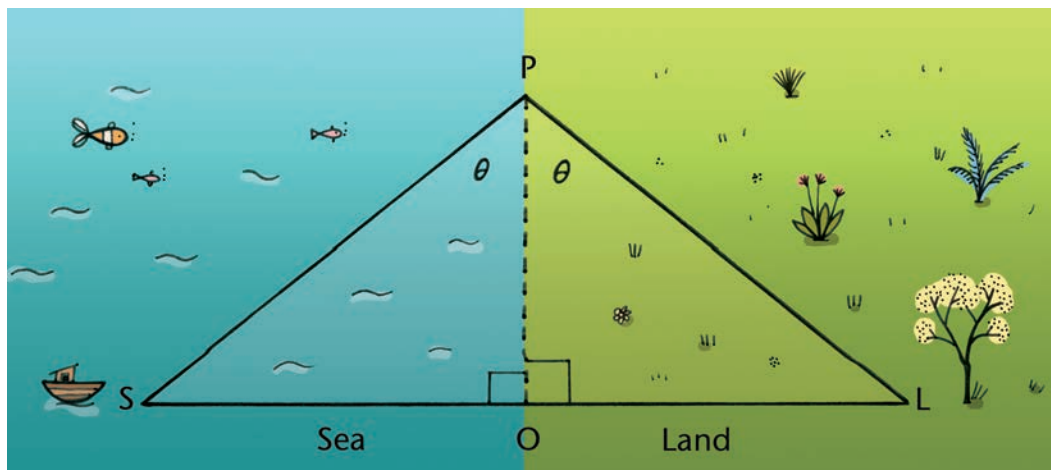

The distance he needed to know is OS . Explain how he used the [AAS] condition to determine the distance OS by making measurements on land. You may assume that the land surface is quite flat.

- 25 In the diagram $EI = EH$ and $SI = SH$:
 Is $\angle H = \angle I$? Explain your reasoning.
 (**Hint:** Redraw the diagram and join E and S .)

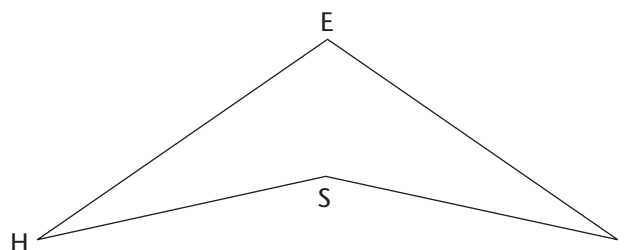

- 26 The figure shows $\triangle TRI$ with two line segments HR and OI with H on IT and O on RT . HR and OI intersect at A . $OR = HI$ and $\angle R_1 = \angle I_1$.
- (a) Show that $\triangle ORA \equiv \triangle HIA$
- (b) Is $HR = OI$? Explain your reasoning.
- (c) Is $\triangle TRI$ isosceles? Explain your reasoning.

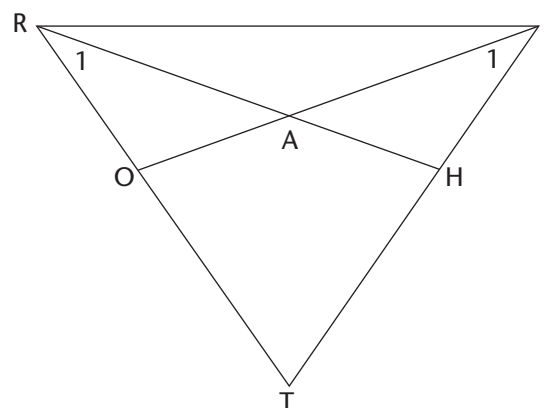

- 27 The dots in the grid are equidistant horizontally and vertically. Show that the two triangles are congruent without making any measurements.

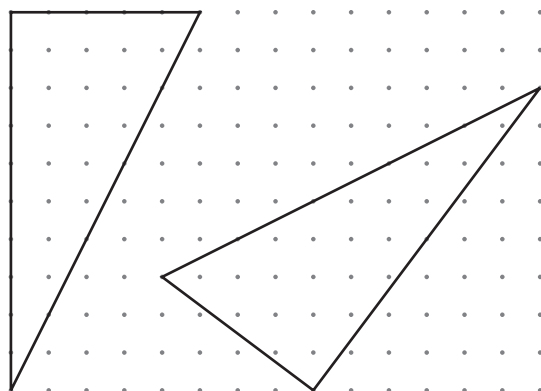

8.4 Similarity of triangles

Exercises Investigating similarity

- 28 Draw a $\triangle PQR$ with PQ precisely 13 cm long, PR precisely 9 cm, and RQ precisely 7 cm long. Measure the sizes of the three angles of your $\triangle PQR$, and write your measurements down.
- 29 Draw another triangle with sides precisely 19,5 cm, 13,5 cm, and 10,5 cm long, with different angle sizes than the above $\triangle PQR$.
- 30 Draw a $\triangle XYZ$ with angles of 50° , 60° , and 70° . Measure the lengths of the three sides of your $\triangle XYZ$, and write your measurements down.
- 31 Try to draw another triangle with angles of 50° , 60° , and 70° , with different side lengths than the above $\triangle XYZ$.
- 32 What have you learnt by doing questions 28 to 31?
- 33 Use each of the line segments below as one side of a triangle. First measure them and construct them on paper. In each case, make an angle of 50° on the left and an angle of 70° on the right and complete the triangle upwards.

What do you expect the size of the third angle will be in each triangle?

Measure the third angles to check whether your constructions are correct.

- Measure all the sides in each triangle and write the measurements next to the sides on each figure.
- Divide the length of the side opposite the angle of 50° in each triangle, by the length of the side at the bottom. Do the answers differ for the different triangles?
- Do the same for the sides opposite the angles of 70° .

What have we learned about similar triangles?

- corresponding angles equal
- ratios of all three pairs of corresponding sides will be equal (what happens if only two corresponding pairs are in the same ratio?)

Note: we can use the words ratio and proportion in more-or-less the same way. We say that two sides are in a particular ratio, but two pairs of sides that have equal ratios are said to be in proportion.

How to decide if two triangles are similar

Term	Definition	Example
angle-angle-angle [AAA]	Show that they have two angles in common; when this is true the third is automatically common	
ratios of the three pairs of corresponding sides are in the same proportion to each other	Show that all three pairs of corresponding sides are in the same proportion	
ratios of the corresponding arms are equal to each other	Show that one angle is the same and the two pairs of arms of the equal angle are in the same proportion	

Triangles with the same angle sizes are called **similar triangles**.

Notation

We use the symbol '|||' as shorthand for 'is similar to', e.g. writing ' $\triangle XYZ \parallel\parallel \triangle MNO$ ' is a short way of writing ' $\triangle XYZ$ is similar to $\triangle MNO$ '.

Worked Example

Problem: In $\triangle ADB$ and $\triangle BEC$, $AD \parallel BE$. $\angle ABD = \angle BCE$. $AD = 7$, $AB = 5$, $BC = 3$, $EC = 1$, $BD = x$ and $BE = y$. Determine the unknown lengths x and y in the following diagram.

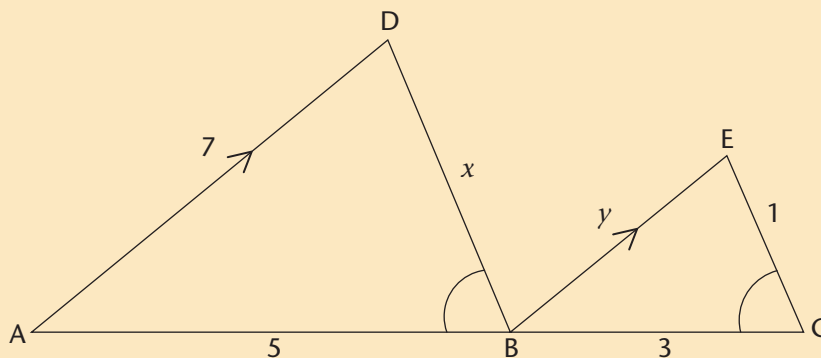

Solution:

In $\triangle ADB$ and $\triangle BEC$:

$$\angle DAB = \angle EBC \quad [AD \parallel BE, \text{ so corresponding angles are equal}]$$

$$\angle ABD = \angle BCE \quad [\text{given information}]$$

So: $\triangle ADB \parallel\parallel \triangle BEC$ [interior angles the same]

Use ratios of corresponding sides to calculate x and y :

$$\frac{x}{1} = \frac{5}{3}$$

$$x = \frac{5}{3} \text{ units}$$

and

$$\frac{y}{7} = \frac{3}{5}$$

$$y = \frac{21}{5} \text{ units}$$

Line parallel to one side of a triangle:

- If $\triangle AMN$ and $\triangle ABC$ are similar, then MN is parallel to BC .
- If MN is parallel to BC , then $\triangle AMN$ is similar to $\triangle ABC$.
- In particular, if $AN = NC$ or $AM = MB$ then $CB = 2 NM$, or, if $CB = 2 NM$ then $AN = NC$ and $AM = MB$.

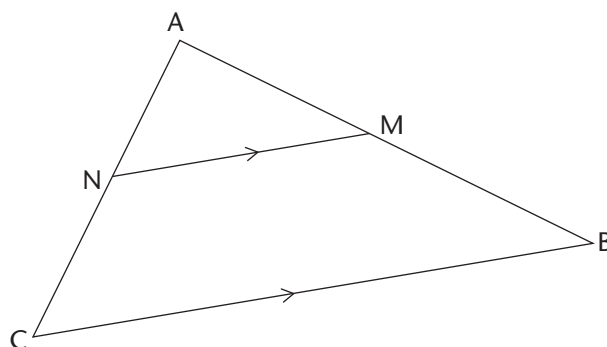

Exercises

34 $\triangle MAD$ has point H on AD joined to point T on AM . $\angle THA = \angle DMA = 70^\circ$.

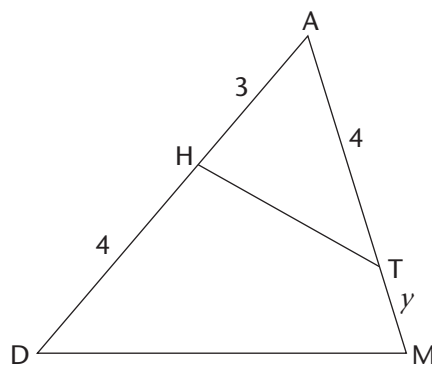

- Complete the statement: $\triangle MAD \parallel \triangle$ _____.
- Calculate the value of y .

35 Each of the sides of $\triangle ABC$ is one third the length of the corresponding sides of $\triangle DEF$.

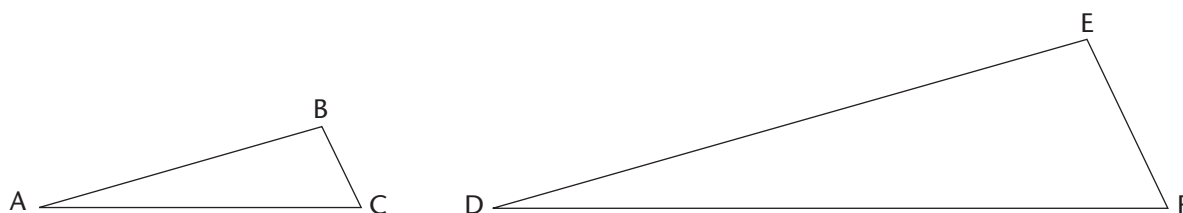

- What relationship exists between the two triangles?
- Give the ratio of the
 - perimeter of $\triangle ABC$ to the perimeter of $\triangle DEF$.
 - area of $\triangle ABC$ to the area of $\triangle DEF$.

36 In the diagram, line MN is parallel to line PQ ($MN \parallel PQ$).

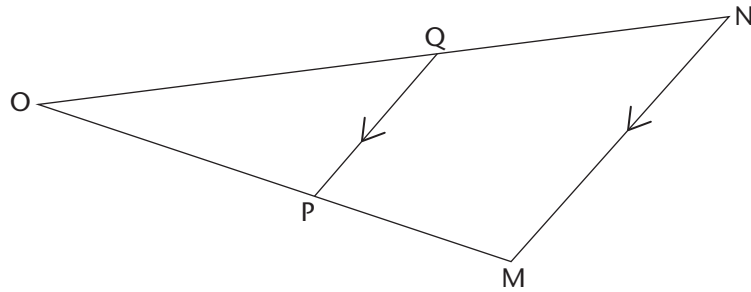

- Prove that $\triangle PQO$ and $\triangle MNO$ are similar.
- It is also given that $MN = 9$ units and $PQ = 6$ units.
 - If $ON = 12$ units, how long is OQ ? (Show your working.)
 - If $OP = 19$ units, how long is PM ? (Show your working.)

37 In the diagram $AW = 15$, $AR = 5$, $AN = 8$, $NS = 4$ and $NR \parallel SE$. Given the following diagram:

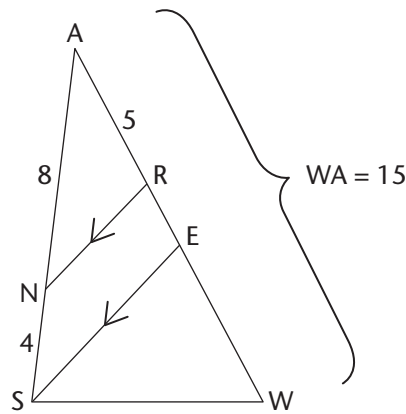

Determine, giving reasons, the following ratios in rational form:

- | | |
|---------------------|---------------------|
| (a) $\frac{AN}{AS}$ | (b) $\frac{AR}{RW}$ |
| (c) $\frac{AR}{RE}$ | (d) $\frac{AE}{EW}$ |

38 In the figure $GF = UF = 3DU = 7$ units and $DG = 2UF$

Calculate, with reasons, the values of:

- GE
- UE

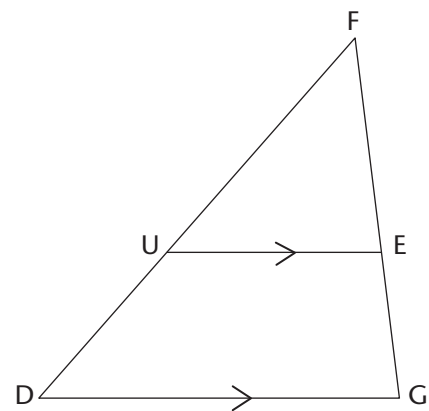

- 39 You will need A4 paper for this exercise. Fold the paper in such a way that one of the corners is exactly on the opposite short edge of the paper:

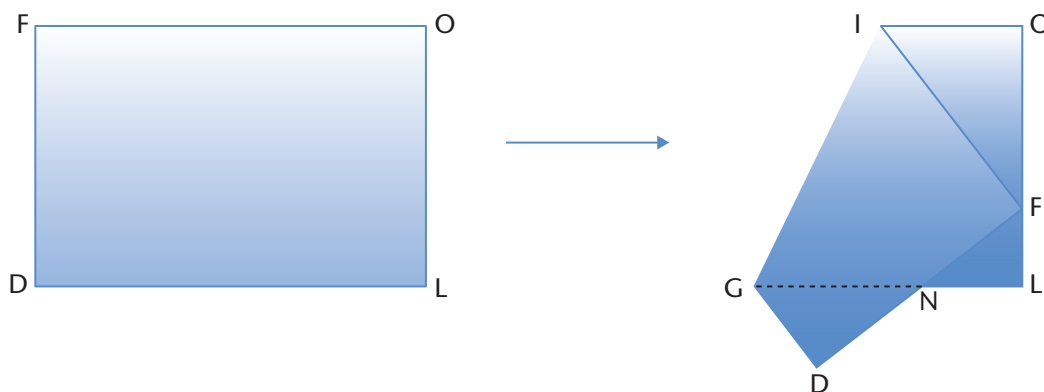

In the process, three triangles are formed by the edges of the sheet.

- (a) What can be said about the geometrical relationship between the three triangles?
Write this relationship down in correct mathematical notation.

- (b) Explain why the three triangles have this relationship.

- (c) Complete:

- $\frac{GD}{GN} = \frac{FL}{?}$
- $\frac{NL}{?} = \frac{LF}{OI}$
- $\frac{?}{IF} = \frac{ND}{OF}$

- (d) Do your results in (a) – (c) depend on where you fold the point F onto the edge OL?

8.5 Investigating quadrilaterals

A **quadrilateral** is a plane figure that has four sides that are straight lines. Quadrilaterals can be either **convex** or **concave**.

Convex quadrilaterals, e.g. the top figure on the right, have all their interior angles in the interval $(0^\circ; 180^\circ)$.

Concave quadrilaterals, e.g. the bottom figure on the right, have one angle that is a reflex angle while the other three are in the interval $(0^\circ; 180^\circ)$.

We will usually deal with convex quads, though we may encounter the concave variety occasionally.

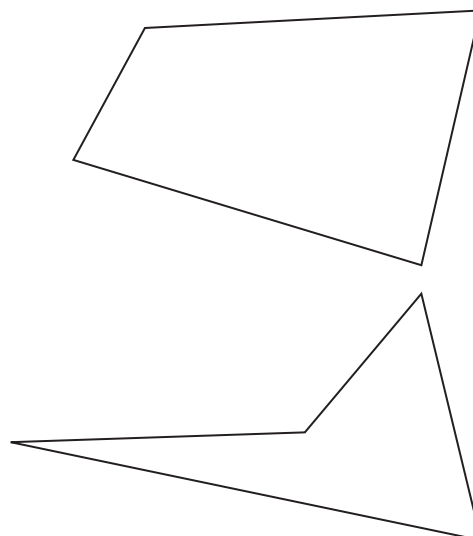

The dynamic quad: A useful tool

We will make use of a 'dynamic quad' constructed from lengths of wood with equally spaced holes. They are connected using small bolts. This allows us to change the shape of the quadrilateral without altering the lengths of the sides. If you are handy in the workshop, you can make your own set.

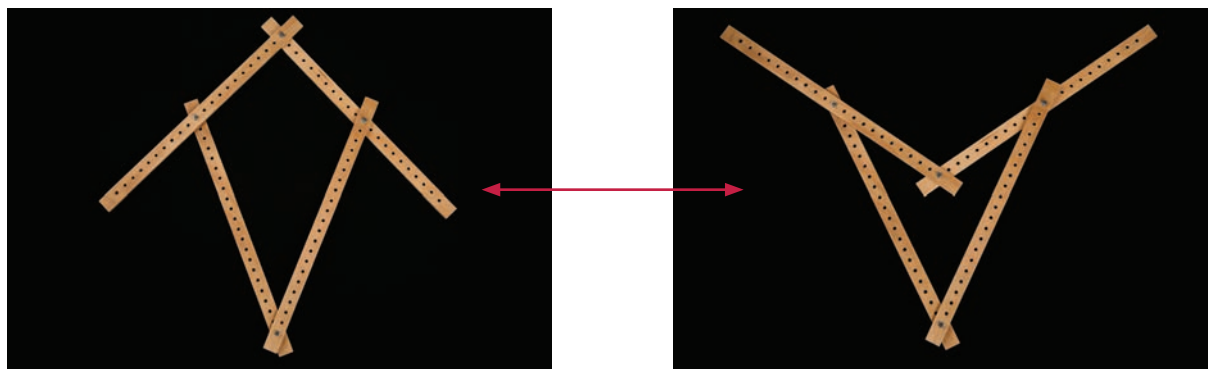

We can count the number of spaces between the holes to compare the lengths of the sides of the quadrilateral. For example, the longer and shorter lengths above are 21 units and 11 units respectively.

An important concept

A **line of symmetry** is a line that runs through a figure so that the part of the figure on one side of the line is an identical mirror image of the part on the other side of the line. This means that the parts of the figure on either side of the line of symmetry are *congruent* to each other.

Exercises Investigating the properties of quadrilaterals

40 Dynamic kites

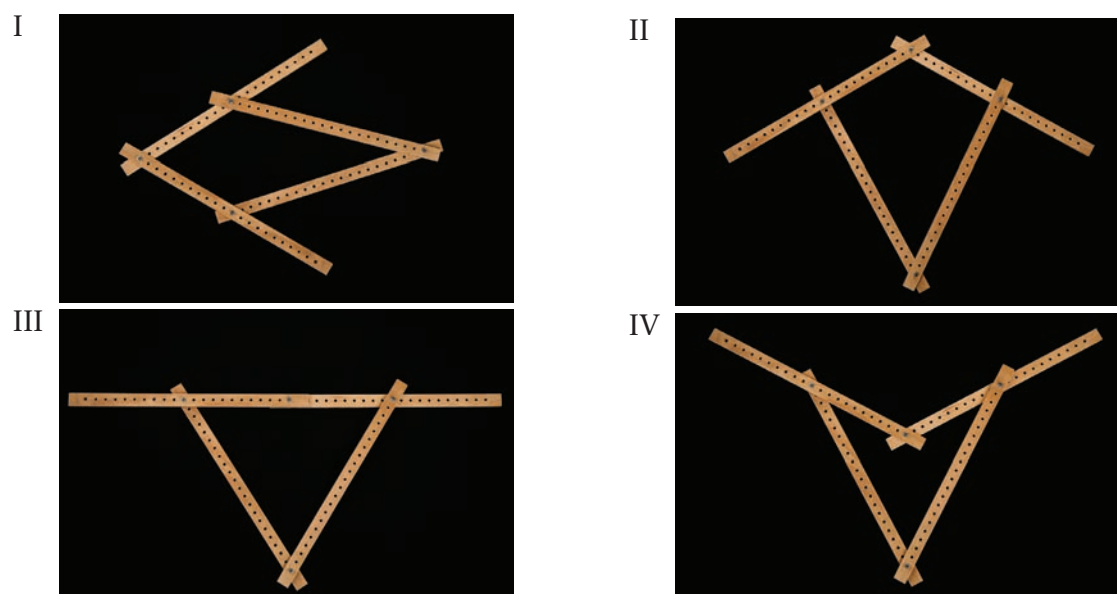

The holes in the dynamic model are 1,5 cm apart.

- Determine the lengths of the sides of the different kites.
- Triangles with three fixed sides are rigid. In other words they cannot change shape, a property that makes them very useful in civil technology.

Are quadrilaterals rigid shapes?

Here are accurate constructions of four such quadrilaterals:

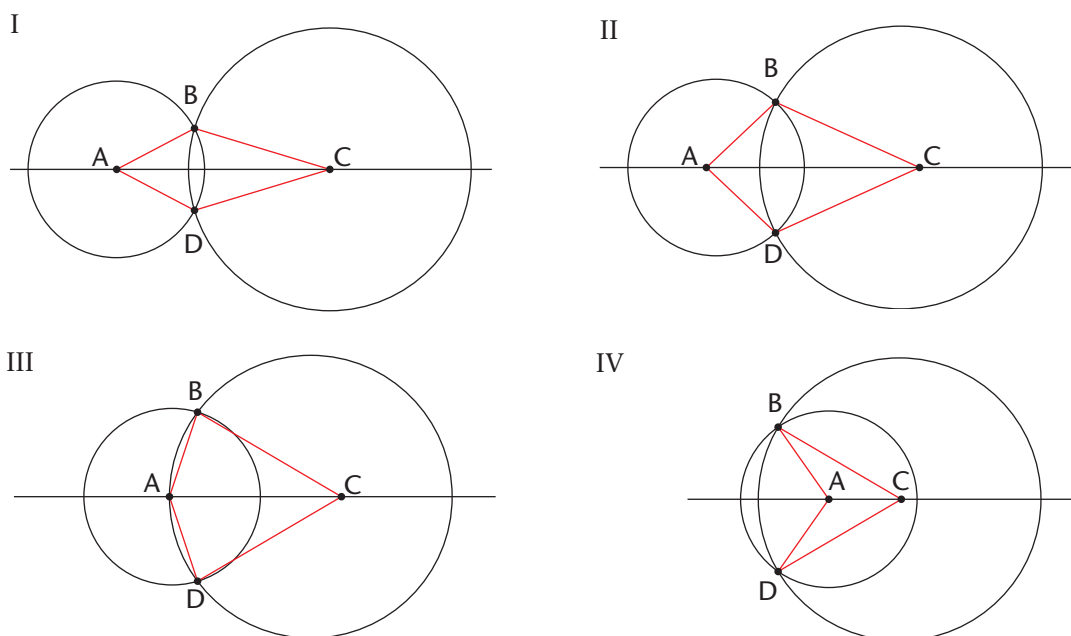

- In each of the quadrilaterals, how is $\triangle ABC$ geometrically related to $\triangle ADC$? Explain your reasoning.
- Based on your findings in (c), what can be said about $\angle B$ and $\angle D$ in each of the kites?
- What can be said about the line that passes through the points A and C? Complete the following sentence:

One diagonal of a kite is always an _____.

- Construct one kite using the above construction. Label the four vertices of the kite as was done above. Draw a line joining points B and D. You now have the two diagonals of the kite: AC and BD. Label their intersection point E. Measure the following:

- the angle between BD and AC
- the lengths BE and ED

What do you conclude? Complete the following sentences:

The diagonals of a kite are _____ to each other.

The diagonal of a kite that lies along its axis of symmetry _____ the other diagonal of the kite.

- (g) List all the properties of kites that you know now.
- (h) Write down definitions, i.e. accurate descriptions, for a kite based on each of the following:
- the lengths of its sides
 - its interior angles
 - its symmetry
 - how its diagonals behave

Once you have done this, compare your definitions with those of some others. Come to a consensus about each definition.

41 Dynamic parallelograms

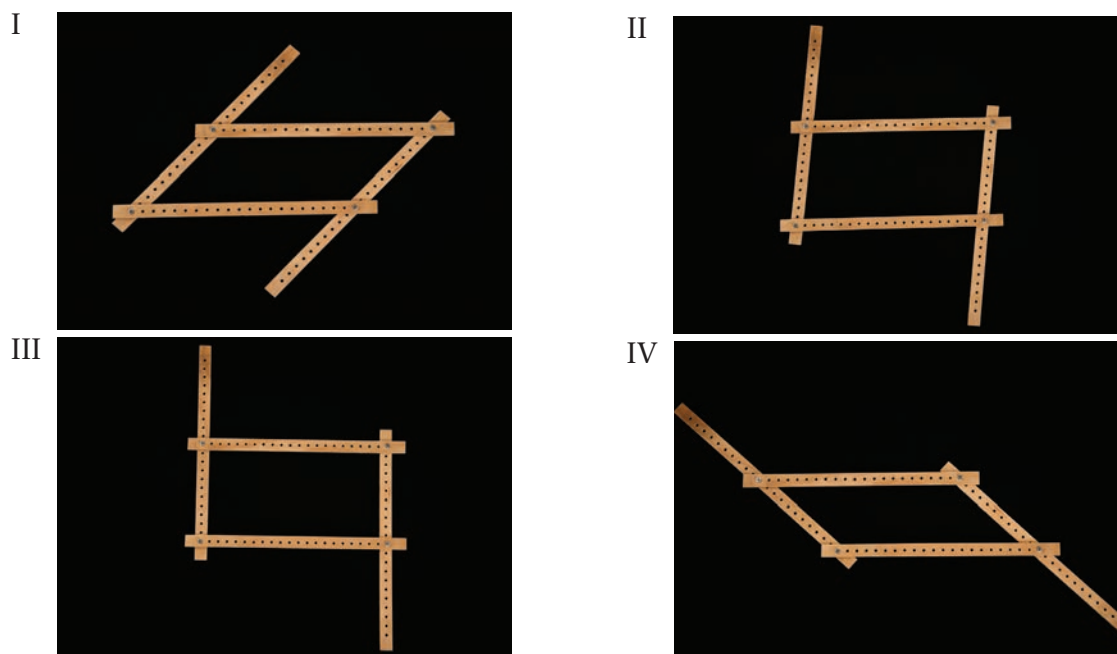

- (a) Determine the lengths of the sides of the four quadrilaterals.
- (b) What properties do the *lengths* of the sides of a parallelogram have?
- (c) Based on the four photographs and your response to (b), explain why a rectangle is a special parallelogram.

Here are accurate constructions of the four parallelograms:

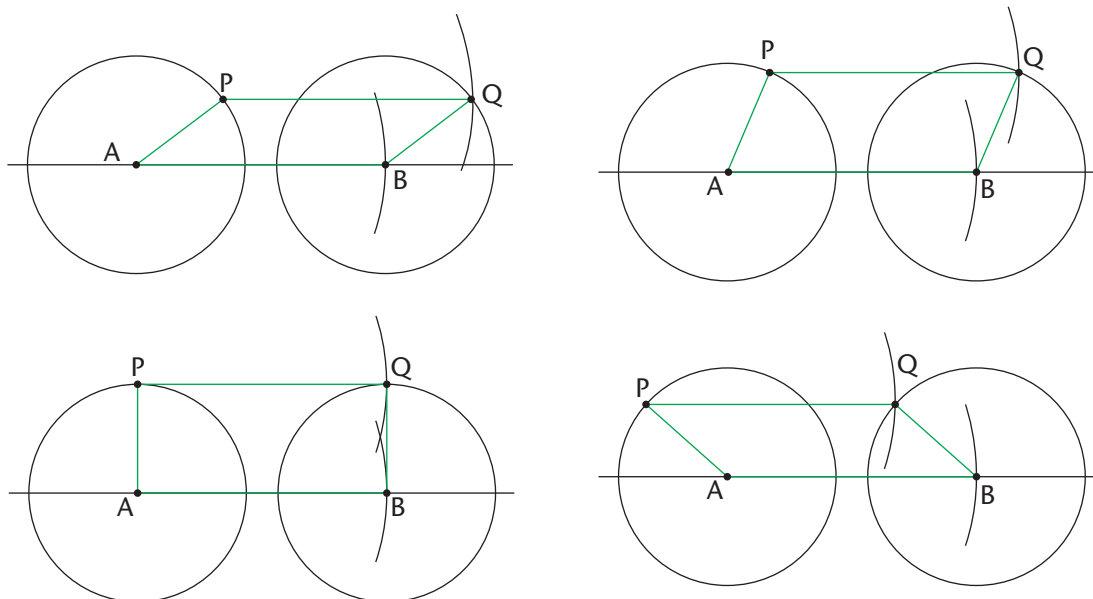

The construction steps are:

- Choose points A and B on a line.
 - Construct two identical circles with centres A and B.
 - Choose a point P on the circumference of the circle with centre A
 - Set your compass to the distance AB – point at A and pencil at B; mark an arc at B.
 - Construct an arc centred at P, intersecting the other circle.
- (d) Construct one parallelogram. Label the four vertices as was done above. Construct the diagonal AQ. What can be said about the geometric relationship between $\triangle APQ$ and $\triangle ABQ$? Explain your reasoning. What does this tell you about the pairs of opposite interior angles of a parallelogram?
- (e) Using your diagram from (d), construct the diagonal BP. Label the point of intersection of the two diagonals E. Measure AE, PE, QE, and BE. What do you conclude about the diagonals of a parallelogram? Complete the following sentence:
- The diagonals of a parallelogram _____ each other.
- (f) Use your result in (d) to explain why both pairs of opposite sides of a parallelogram are parallel.
- (g) List all the properties of parallelograms that you know now.
- (h) Write down definitions for a parallelogram that are based on each of the following:
- the lengths of its sides
 - its interior angles
 - how its diagonals behave
- (i) Can a parallelogram have an axis of symmetry? Does no parallelogram have an axis of symmetry?

42 Dynamic rhombuses

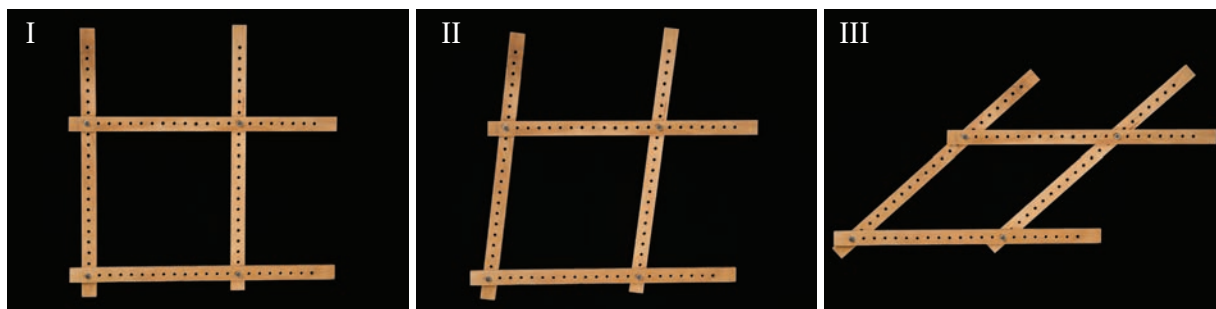

- (a) Based on the above photographs and the photos in Exercises 40 and 41, decide whether you agree, or not, with the following and explain your reasoning in each case:
- I. A square is a special rectangle.
 - II. A parallelogram is a special rhombus.
 - III. A square is a special parallelogram.
 - IV. A kite is a special rhombus.
 - V. A square is a special kite.
- (b) Use the construction method in Exercise 41 to construct three rhombuses that look like the ones in the photo. To do this, let $AB = \text{radii of circles} = 10 \text{ cm}$. Label the vertices exactly the same as was done for the parallelograms. Use your diagrams in (c) and (d) that follow.
- (c) Investigate if rhombuses have the properties of a parallelogram.
- (d) Investigate the properties rhombuses have that parallelograms do not generally have.
- (e) Make a list of all the properties of rhombuses that you know now.
- (f) Write down definitions for a rhombus that are based on each of the following:
- I. the lengths of its sides
 - II. its interior angles
 - III. how its diagonals behave
 - IV. its axes of symmetry (there are two)
- (g) Can a parallelogram have an axis of symmetry? Does no parallelogram have an axis of symmetry?

43 Rectangles and squares

- (a) Write down all the properties that rectangles and squares have in common.
- (b) Are there any properties that rectangles have that squares do not have?
- (c) Are there any properties that squares have that rectangles do not have?
- (d) Is a rectangle a type of rhombus?
- (e) Is a square a type of rectangle?
- (f) Write down as many definitions for a square as you can.
- (g) Write down as many definitions for a rectangle as you can.

44 Investigate the properties of trapeziums.

- (a) Construct four different trapeziums using a ruler and compass. You have to make sure that they are very different from each other.
- (b) Make a list of the properties of trapeziums.
- (c) Write down as many definitions as possible for a trapezium.
- (d) Based on what you now about the properties of all kinds of quadrilaterals we have investigated, are
 - trapeziums parallelograms?
 - rhombuses trapeziums?
 - squares trapeziums?
 - parallelograms trapeziums?
 - rectangles trapeziums?

45 Pulling all the investigations together:

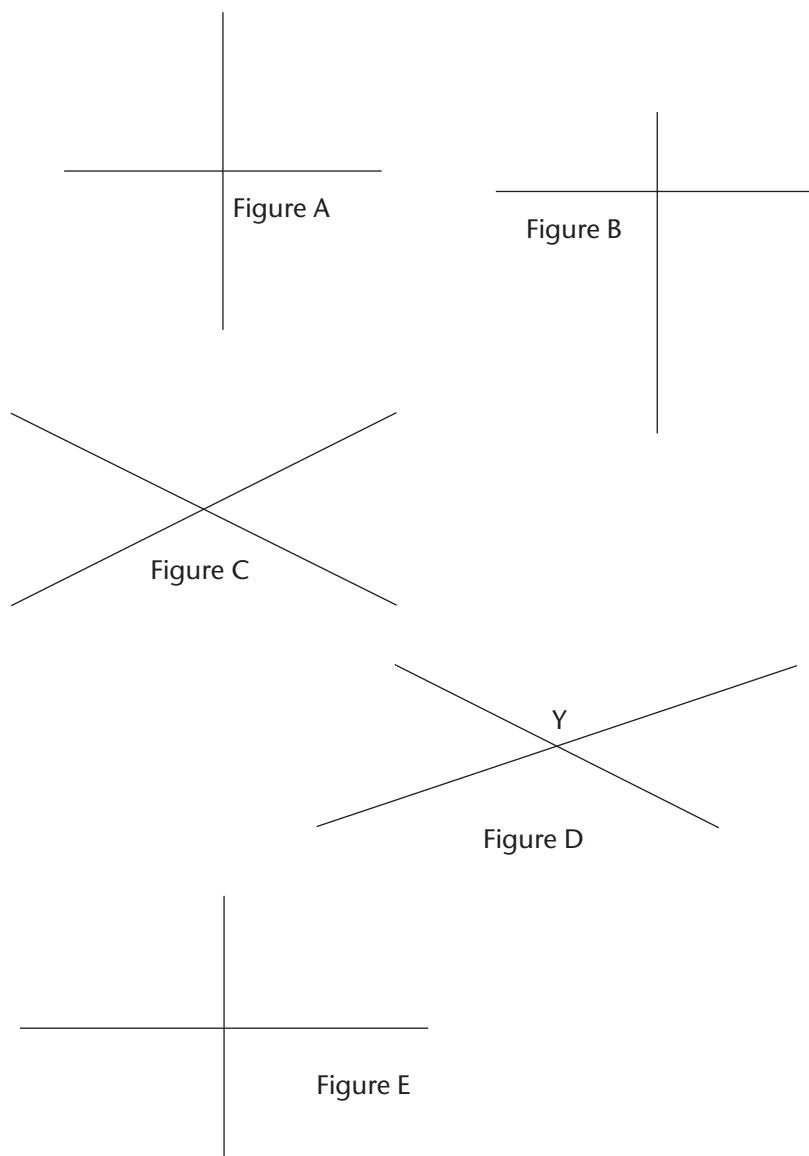

In each of the figures you see two line segments intersecting:

- In which of the figures are the two line segments equal in length?
- In which figures does one line segment bisect the other?
- In which of the figures do the two line segments bisect each other?
- In which figures are the two line segments perpendicular to each other?

Note: The word 'bisect' means 'cut in half'.

(e) Complete the table of properties for the figures (just answer 'yes' or 'no'):

	Fig A	Fig B	Fig C	Fig D	Fig E
Two line segments are equal					
At least one line segment bisects the other one					
Two line segments bisect each other					
Two line segments are perpendicular					

Now, the ends of the line segments have been connected to form quadrilaterals:

Figure A

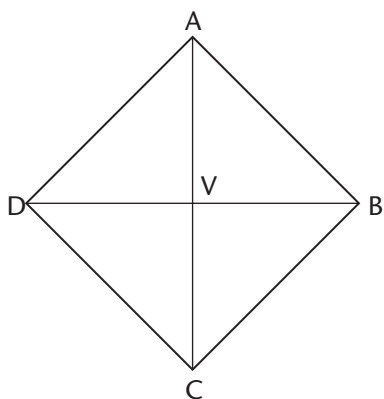

Figure B

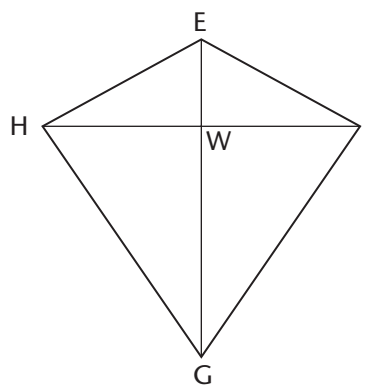

Figure C

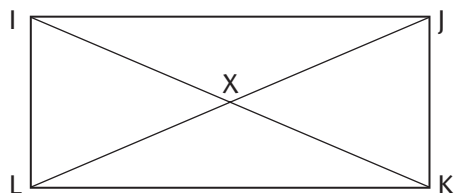

Figure D

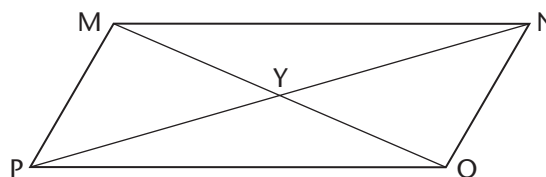
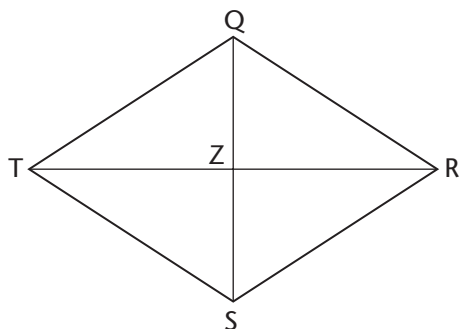

Figure E



The line segments have now become diagonals of the quadrilaterals.

- (f) For each figure, identify the triangles that are congruent.
- (g) Use your results from (e) and the congruencies in (f) to complete the following table of properties of the quadrilaterals:

	Fig A	Fig B	Fig C	Fig D	Fig E
Two diagonals are equal					
At least one diagonal bisects the other one					
Two diagonals bisect each other					
Two diagonals are perpendicular					
Opposite sides are parallel					
Two adjacent sides are equal and other two adjacent sides are also equal					
Two opposite angles equal					
Two opposite angles equal and other two opposite angles also equal					

The Hierarchy of Quadrilaterals

We can now arrange the different kinds of quadrilaterals in a hierarchy, that is, a structure such as the hierarchy of real numbers we saw in Chapter 2. Any quad that is lower down in the hierarchy has all the properties of any quadrilateral that is higher up:

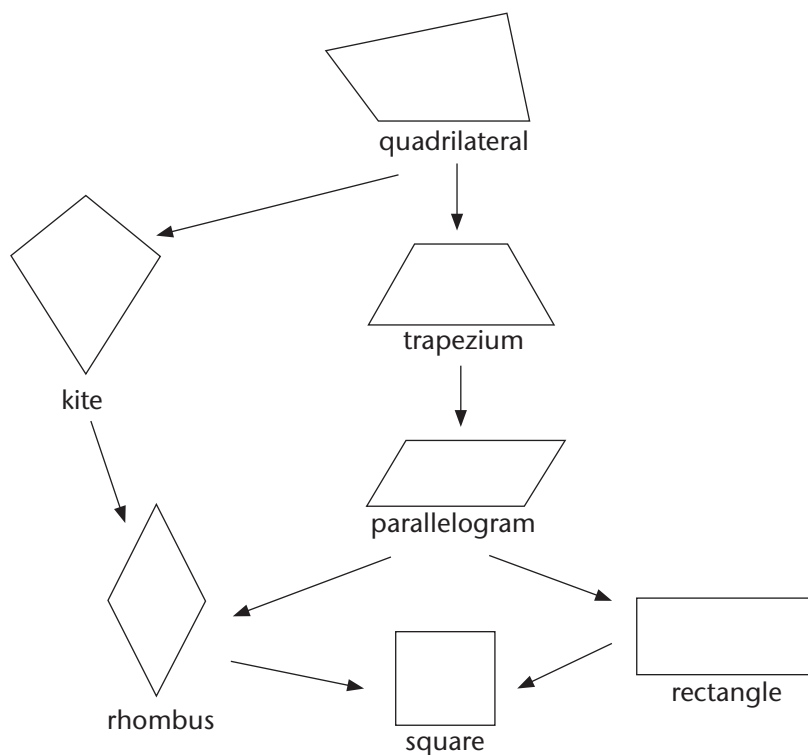

How to be the Master of the Quads

If you understand:

- that each kind of quadrilateral can be defined in many ways (using relationships between sides, between angles and between diagonals),
- that you understand each of those definitions very well,
- and that you understand how the different types of quads are related in the hierarchy, you will find that dealing with quadrilaterals will be much more straight-forward than if you just memorise all the properties of each type of quad.

Exercises

46 Here is a parallelogram ABCD with a diagonal AC:

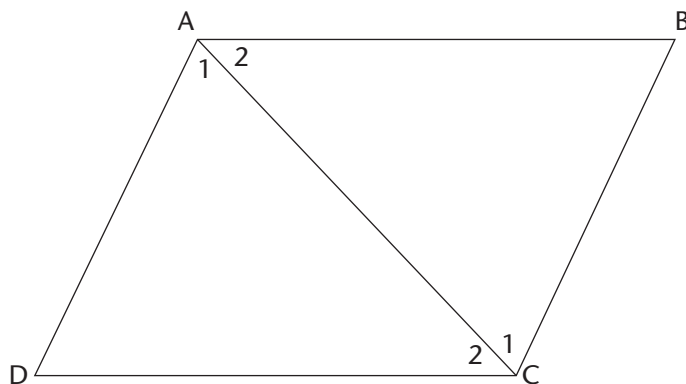

- (a) Fill in the missing words: The opposite sides of a parallelogram are _____ and _____.
- (b) Explain briefly why $\angle A_1 = \angle C_1$ and why $\angle A_2 = \angle C_2$.
- 47 State whether the following statements are true or false; give a reason for the false statement:
- (a) All squares are similar.
- (b) If two triangles have two sides and an angle equal then they are congruent.
- (c) If two pentagons have all five of their sides the same lengths then they are congruent.
- (d) All squares are rhombuses.
- (e) A square has the properties of all the convex quadrilaterals.
- (f) Two isosceles triangles with a base angle in common are similar.

- (g) Two triangles with two angles and a side in common are congruent.
- (h) If a quadrilateral has diagonals intersecting at 90° then it is a kite.
- (i) To say that a given quadrilateral is a parallelogram, is enough to show that it has a pair of sides equal and a pair of opposite sides parallel.

48 Consider the following collection of quadrilaterals on a dotted grid (the dots are *evenly* spaced):

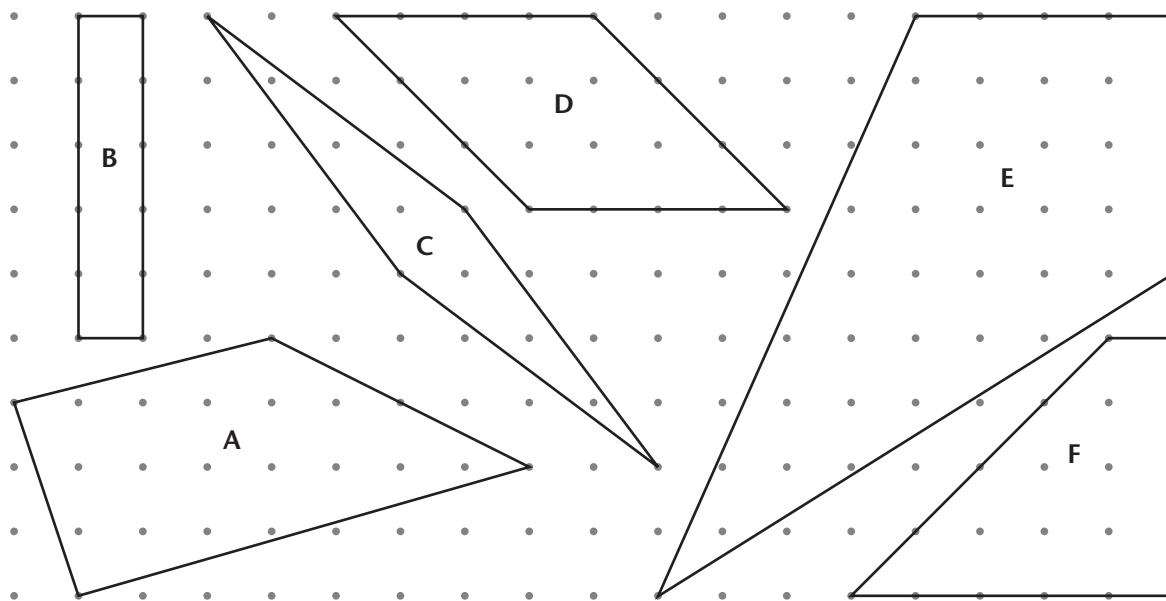

Give the labels (A – F) of the quadrilaterals (if any) that meet the following criteria:

- (a) parallelograms without an axis of symmetry
- (b) with exactly one pair of opposite, interior angles equal
- (c) neither a kite nor a trapezium
- (d) with two axes of symmetry
- (e) with the same area as F
- (f) parallelograms but not rhombuses
- (g) rectangles
- (h) trapeziums but not rectangles
- (i) both trapeziums and kites
- (j) neither rhombuses nor rectangles

49 Answer this question on sheets of dotted paper. (See the ADDENDUM to this chapter for more about working with dotted paper and square grids.) Draw the figure described on the dotted paper grid. There is an example to show what is required. In some cases, there is more than one possible figure you could draw. You only need to provide one drawing, but feel free to do more than this. The horizontal or vertical space between two dots is 1 unit.

- (a) A quadrilateral with diagonals of lengths 4 and 8 units. The longer diagonal is the perpendicular bisector of the shorter one.
- (b) A trapezium that is not a parallelogram, and which has one pair of opposite angles obtuse, and a third angle of 45° .
- (c) An isosceles triangle with a base of length 6 units and the opposite angle to the base 90° .
- (d) A parallelogram with one pair of sides of length 5 units and the other pair with lengths of $\sqrt{10}$ units.
- (e) Draw a rhombus with sides 13 units.

An example of what to do: Draw a parallelogram with sides 5 units and $\sqrt{20}$ units

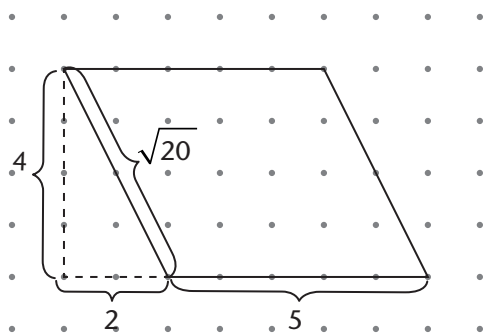

Note: If you cannot access dotted paper you can use square grid paper instead.

50 You find the following definition of a kite:

‘A kite is any quadrilateral with perpendicular diagonals, one of which bisects the other.’

Comment on this ‘definition’ and say whether you agree or not. Explain your reasoning. Include a diagram.

51 Say whether the following statements are True, or False. If you say a statement is False, you must provide a counterexample, and you must correct the statement

- (a) All congruent octagons are similar.
- (a) All quadrilaterals with diagonals of equal length are rectangles.
- (b) A rhombus is a trapezium.
- (c) Squares are the only quadrilaterals that are both kites and trapeziums.

52 Consider the following collection of quadrilaterals (the dots are evenly spaced):

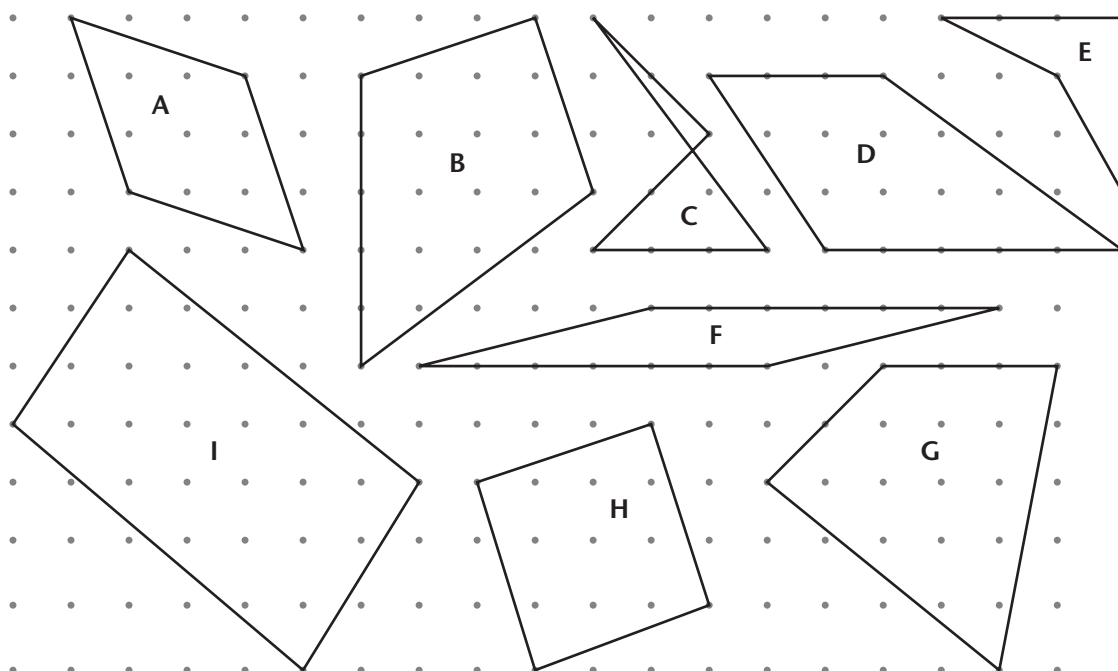

Give the labels (A – I) of the quadrilaterals (if any) that meet the following criteria:

- (a) concave
- (b) parallelograms without an axis of symmetry
- (c) with exactly one pair of opposite, interior angles equal
- (d) neither a kite nor a trapezium but convex
- (e) with four axes of symmetry
- (f) has a pair of equal adjacent sides

- 53 (a) In the diagram UN, TO, SW, RM, WO, WQ and SQ are all straight lines. Provide the missing angles $a - f$ in the following diagram. Provide only the values of the angles (no reasons necessary.) Do not guess. Check your values for consistency, i.e. do they make sense with other values you have found.

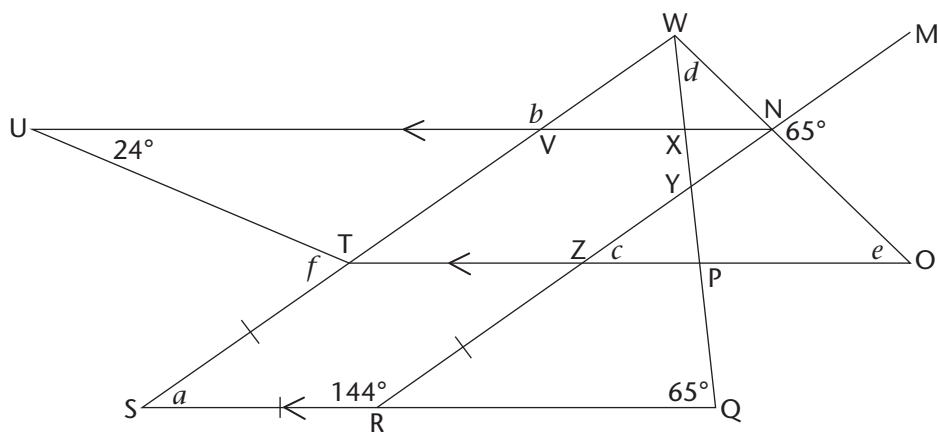

- (b) In the diagram below, CE is a straight line and AD and BC are diagonals of quadrilateral ABDC. Provide the lengths $p - s$ in the diagram. Do not guess. Check your values for consistency, i.e. do they make sense with other values you have found.

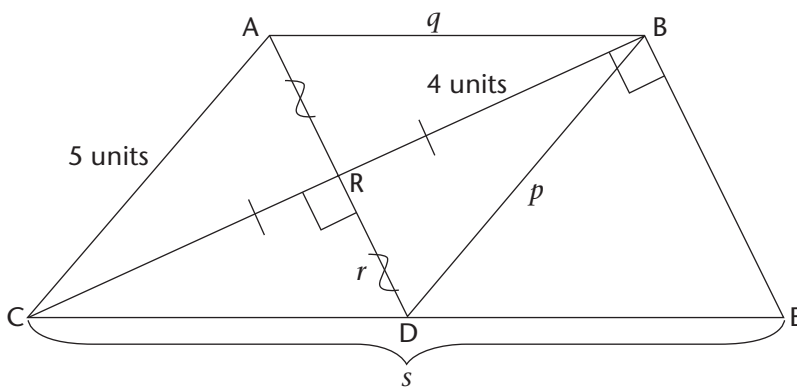

- 54 In the diagram below, ST and TU are straight lines. Find the unknown angles:

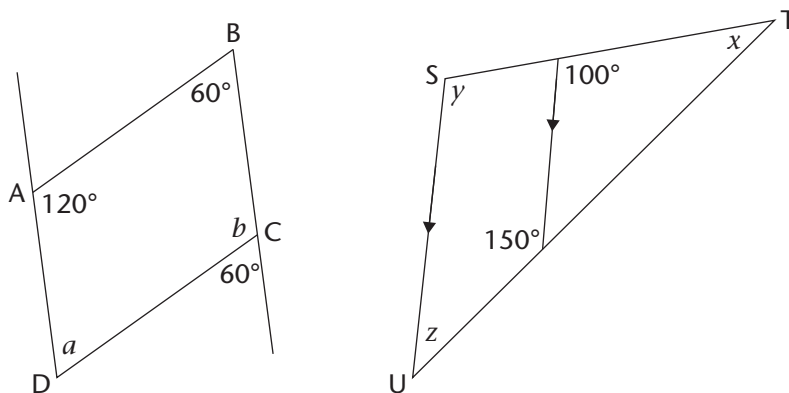

55 ABCD is a parallelogram. ADE is a triangle attached to it. CDE is a straight line. AB has length 10 mm and BC is 5 mm long.

The perpendicular height of ABCD from BC is 8 mm (the dotted line). Remember to include the correct units with your answers here.

- Calculate the area of the parallelogram.
- Now determine x , the length of the dotted line in the triangle.
- If the area of the triangle is one quarter of the area of the parallelogram, calculate the length of the whole of CE.

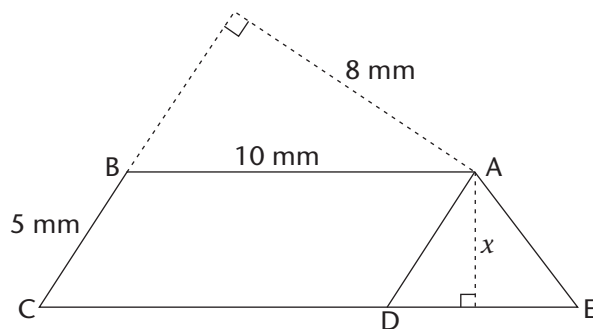

8.6 The Pythagorean Theorem

The Pythagorean Theorem links the lengths of the sides of a right-angled triangle:

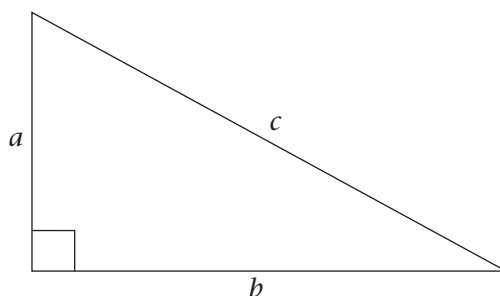

It states that $a^2 + b^2$ is always the same as c^2 .

No exceptions.

In words: The square of the hypotenuse is equal to the sum of the squares of the two remaining sides.

Seeing the theorem for integer lengths of the sides:

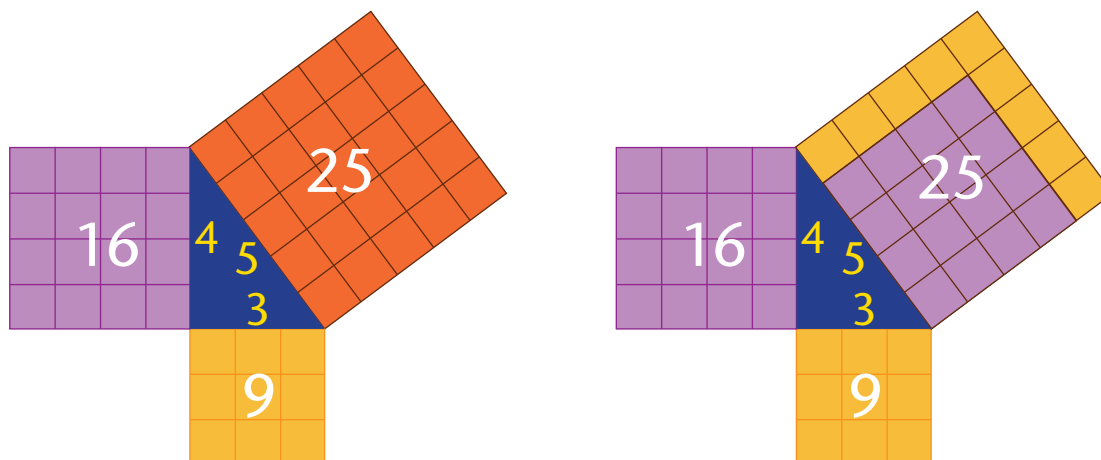

You can use the Pythagorean Theorem for two things:

- If you know the lengths of all three sides of a triangle, you can decide if an angle is a right-angle: calculate the squares of the three sides and see if the two smaller ones add up to the biggest one.
- If you know you have a right-angled triangle and two of the sides, you can calculate the length of the third side.

Important, this links up with trigonometry, where you can use the trigonometry functions to do things the Pythagorean Theorem cannot do on its own: calculate angles from sides, and sides from angles.

Exercises

- 56 Confirm that the two triangles below are right-angled. The holes in the lengths of plywood are equally spaced so you can 'read off' their relative lengths by counting the number of intervals between the holes. One or two holes are obscured in the second photograph, so you will have to make sure that you include these.



- 57 In $\triangle ABC$ it is given that $\angle C = 90^\circ$. Complete: $\underline{\hspace{2cm}}^2 = \underline{\hspace{2cm}}^2 + \underline{\hspace{2cm}}^2$.

58 Calculate the unknown values in the following triangles, giving your answers to an three significant figures where necessary:

(a)

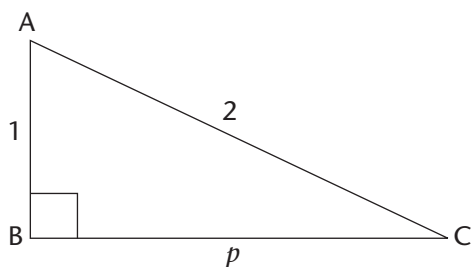

(b)

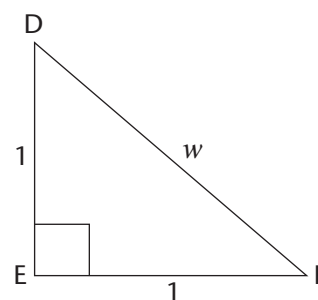

(c)

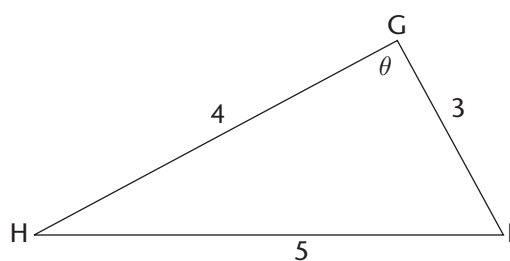

(d)

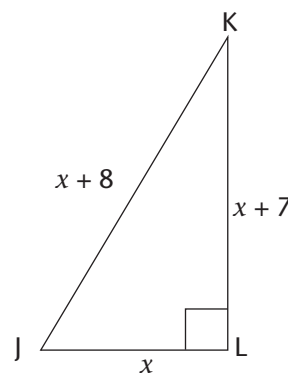

(e)

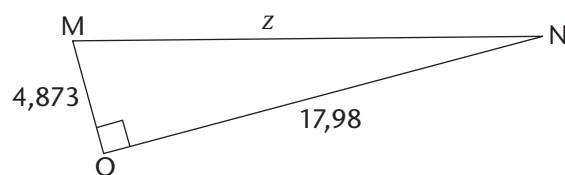

59 Use the diagram to determine the following:

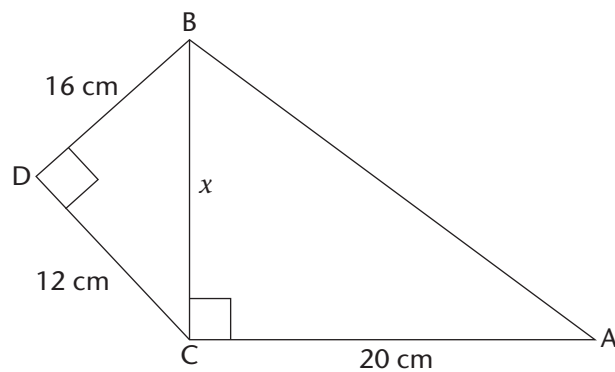

(a) x , the length of BC

(b) $\angle BAC$

(c) the area of quadrilateral $ABDC$ (with correct units)

(d) the perimeter (2 decimal places) of $ABDC$ (with correct units)

- 60 An old way used by builders to mark off a right angle on the ground is to use a piece of rope of length 12 m that is tied at its ends – i.e. the distance along the rope from I back to I is 12 m. The distances along the rope from I to J, from J to K and from K to I again are 3 m, 4 m, and 5 m respectively:

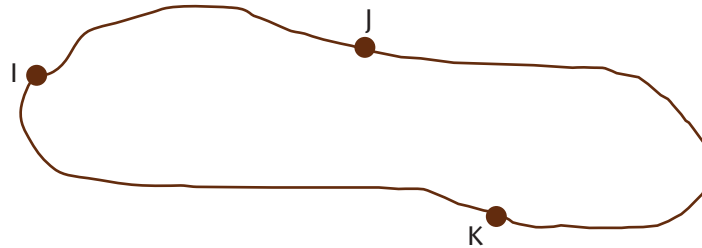

Explain how to mark off a right angle on the ground using three pegs and the rope. Make a drawing to show what you mean.

- 61 Shown is a semi-circle with centre O and diameter QR. $\triangle PQR$ is drawn, where P is any point on the arc of the semi-circle. Radius OP is drawn. Point S is chosen on PR so that OS is parallel to PQ. $\angle PQR = 54^\circ$.

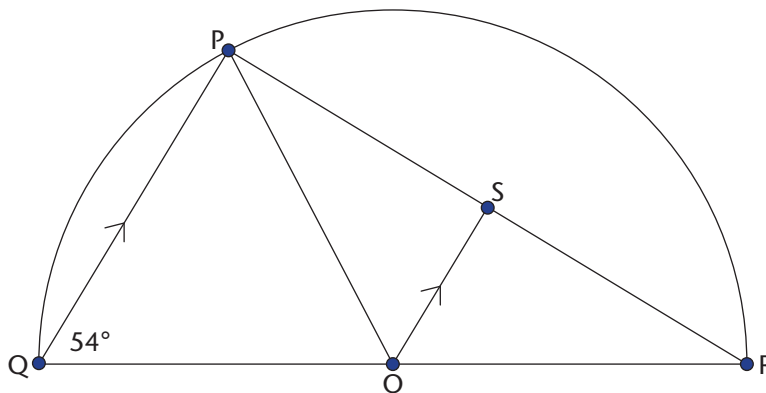

- There are three other angles equal to 54° . Determine, with reasons, which ones they are.
- Prove that $\triangle SOP$ is congruent to $\triangle SOR$.
- Show that $\angle QPR$ is a right-angle. (**Hint:** what is the size of $\angle OPS$?)
- What can you say about $\triangle RSO$ and $\triangle RPQ$?
- What are the following ratios?
 - RO:OQ
 - RS:RP
 - PQ:SO
- If the radius of the circle is 10 cm, calculate all the remaining lengths in the diagram. Use these to check your answers to (b), (d), and (e).

-
- 62 The triangle below is drawn on dotted paper. Use the Pythagorean Theorem to show that the largest angle in the triangle is a right angle.

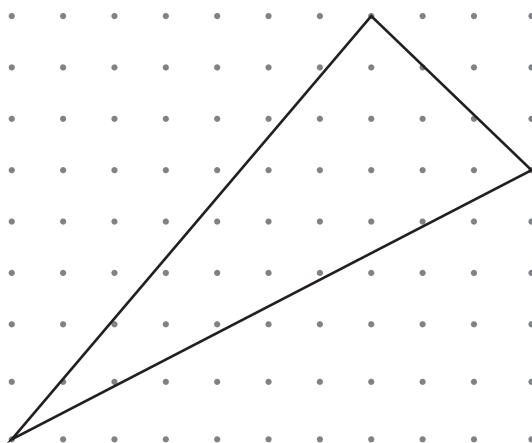

8.7 Summary

In this chapter you have revised and developed the following

- the concept of angles, and you deepened your understanding of an angle as a fraction of a full revolution of 360°
- your understanding of parallel lines
- angle relationships involving intersecting lines, a transversal through two parallel lines
- the properties of triangles and how the different types of triangles relate to each other
- your understanding of similarity and congruence of triangles
- your understanding of the types of quadrilaterals, that they are defined in many possible ways and that they are related in a hierarchical way
- the Pythagorean Theorem
- using and applying all of these understandings to problems

8.8 Consolidation exercises

- 1 Show that $\triangle PQR \cong \triangle LQM$

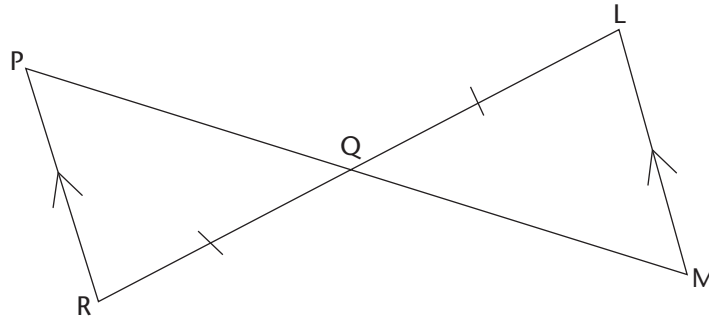

- 2 If PQRS is a rhombus and angle RPS is 25° , calculate the sizes of x and y .

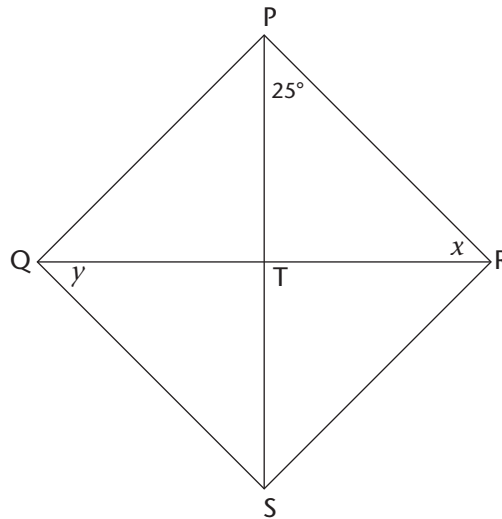

- 3 Refer to the diagram below. Calculate, \hat{A} , \hat{B} , \hat{C} , and \hat{D} .

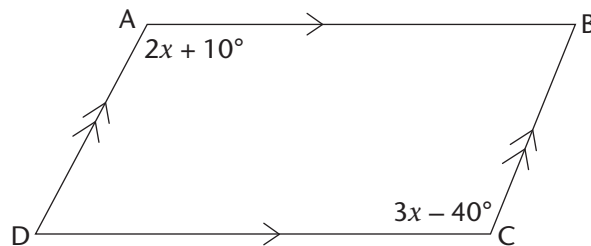

- 4 Refer to the diagram below. ABCD is a parallelogram. $AD = DE$ and $CB = CE$. Calculate x and y .

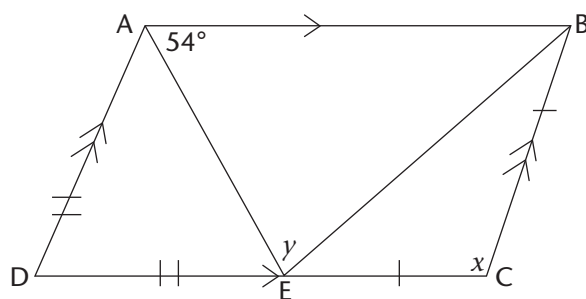

- 5 In the diagram, D and E are the midpoints of AC and BD respectively. Prove that $BF = FG = GC$.

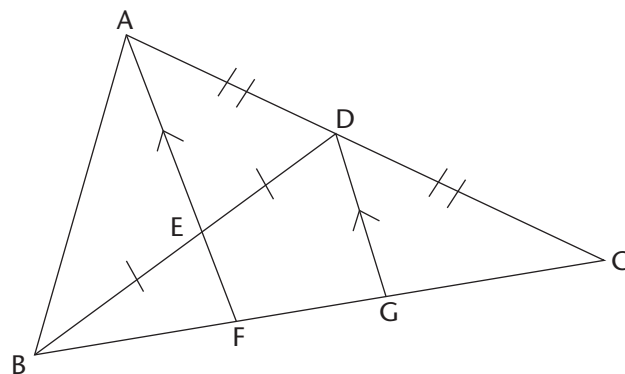

- 6 ABEF is a parallelogram. Calculate x and y if $SA = SF$.

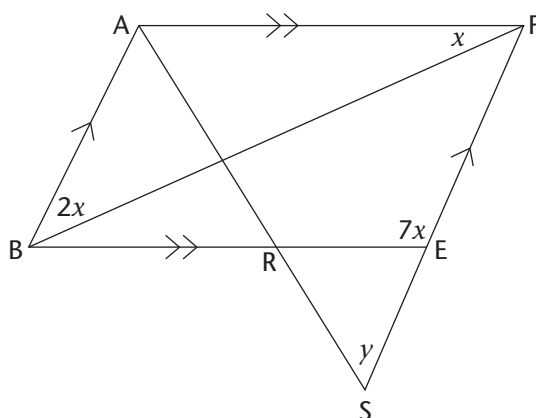

- 7 Find the lengths of sides a , b , and c .

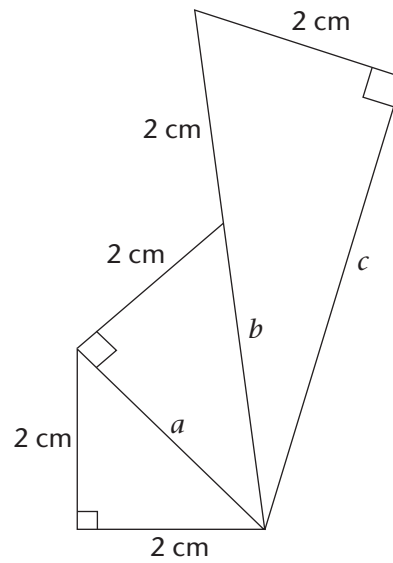

- 8 Triangles that are similar to a right angled triangle with sides 3, 4, and 5 are often used in construction. The roof shown here is 36 m wide. The two halves of the roof are congruent. Each half is a right angled triangle with sides proportional to 3, 4, and 5. The shorter side is the vertical side.
- (a) How high above the attic floor should the roof peak be?
- (b) How far is the roof peak from the roof edge?
- (c) What is the shingled area of the roof if the building is 48 m long?

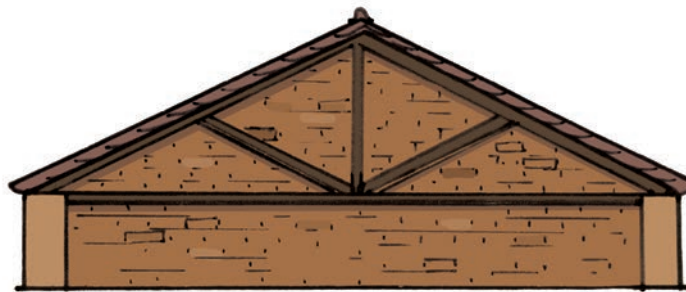

- 9 The launching pad for a hot air balloon is 1 609 m away from where you are standing. If the balloon rises vertically 914 m into the air, how far in centimetres will it be from you?

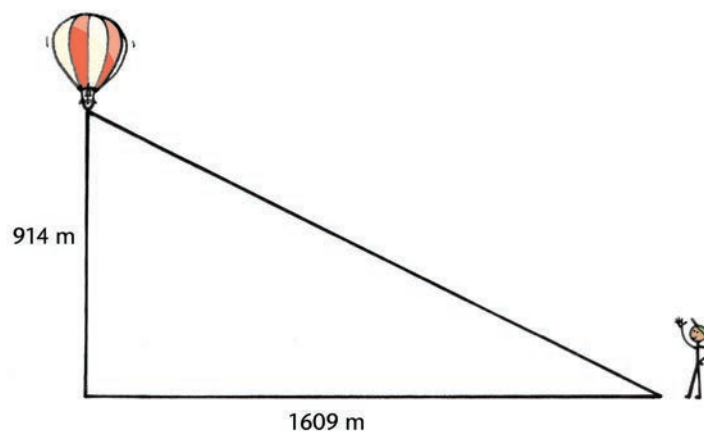

- 10 A ladder, 8 m long, is placed against a wall 3 m from its base. Calculate the height reached by the ladder.
- 11 The diagonal of a rectangular gate is 4,5 m long. If the gate is 4 m wide, what is its height?
- 12 In the figure, AD and HK are transversals of PQ and RQ, with lengths and angles as indicated.

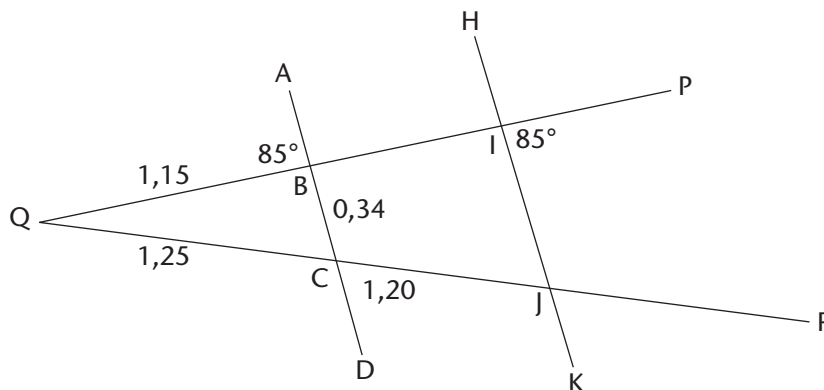

- (a) Show that $AD \parallel HK$.
- (b) Calculate the length of IJ and BI.

ADDENDUM Dotted Paper

Dotted paper is a useful tool for investigating geometrical properties of shapes. The dots are arranged in a square grid pattern:

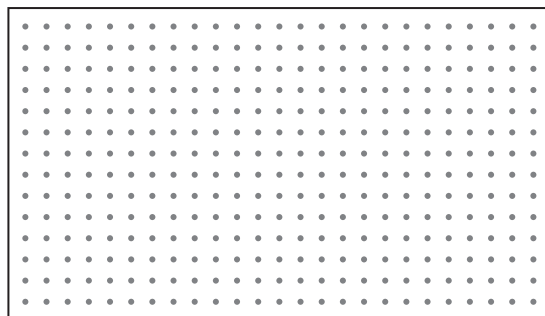

Here are a few examples to show how the grid works:

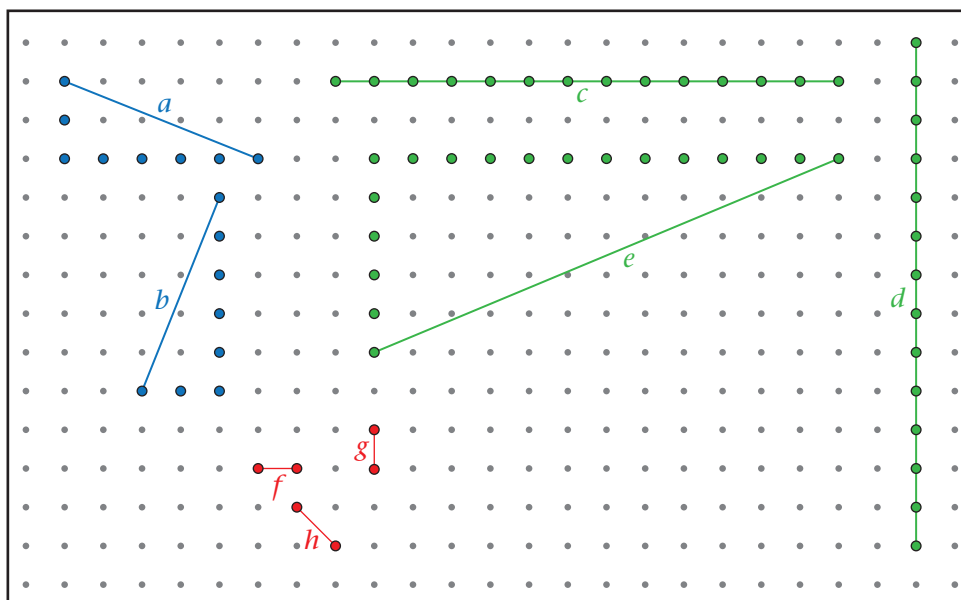

Line segments a and b are equal in length. This can be seen because their sides along the gridlines have lengths 2 units and 5 units. Moreover, a and b will be perpendicular to each other since they have reciprocal *rise:run* ratios.

Line segments c , d , and e all have the same lengths, 13 units. We can see this because the rise and run for e are 5 units and 12 units, which according to Pythagoras' Theorem makes e 's length 13 units. The triples $[3; 4; 5]$ and $[5; 12; 13]$ are called Pythagorean triples and these are very useful because the sides and hypotenuse are integers.

A common mistake made is confusing lengths along the gridlines with lengths diagonally between two points. Line segments f and g are both 1 unit long. Line segment h is 1,414 ... units long, NOT 1 UNIT long!

9 ANALYTICAL GEOMETRY

‘Each problem that I solved became a rule, which served afterwards to solve other problems’
(Rene Descartes, 1637).

In this chapter, you will learn:

- how to represent geometric figures on a Cartesian coordinate system and apply formulae for determining:
 - distances between points
 - midpoint of line segments
 - gradient of line segments connecting two points
 - equation of a straight line passing through set points

9.1 Using the Cartesian plane to locate points

The position of any point on a Cartesian plane can be specified by means of an ordered pair of numbers $(x; y)$ where:

- the x -coordinate of a point is the value that tells us how far left or right the point is along the horizontal axis, also known as the x -axis.
- the y -coordinate of a point is the value that tells us how far up or down the point is along the vertical axis, also known as the y -axis.

Exercises

Consider the point A with coordinates $(4; 3)$ shown on the Cartesian plane, below.

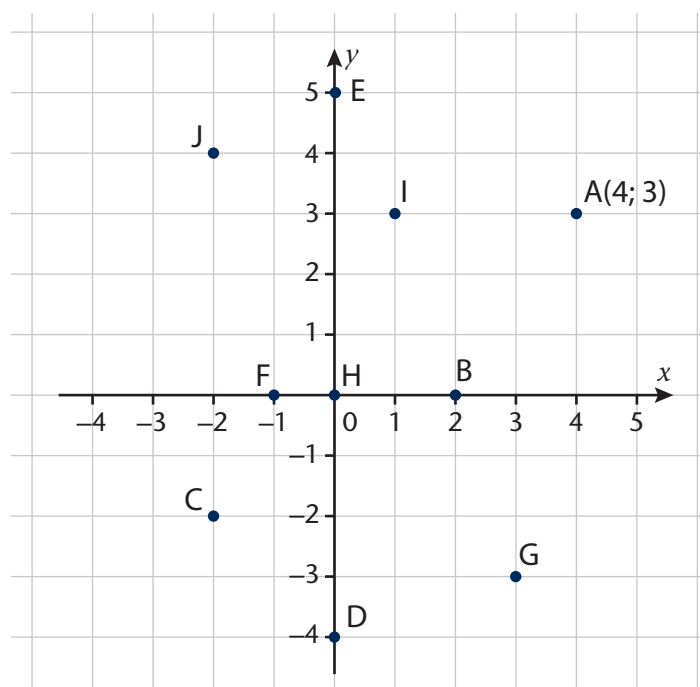

- 1 Answer the following questions:
 - (a) What is the y -coordinate of the point A?
 - (b) What is the x -coordinate of the point A?
- 2 Explain what each coordinate tells us about point A.
- 3 Write down the coordinates of the points B to J.
- 4 Draw a Cartesian plane and plot the points with the given coordinates below:
 - (a) $P(-4; 1)$
 - (b) $Q(7; -5)$
 - (c) $R(6; 5)$
 - (d) $S(-2; -3)$
 - (e) $T(0; 2)$
 - (f) $U(2; 0)$
 - (g) $V(-1; 0)$
 - (h) $W(0; -1)$

9.2 Distance between two points

Distance between two points with the same x -coordinates or y -coordinates

Suppose we have points $A(3; 2)$ and $B(7; 2)$, with the same y -coordinates as plotted on the Cartesian plane below and we want to find the distance between them.

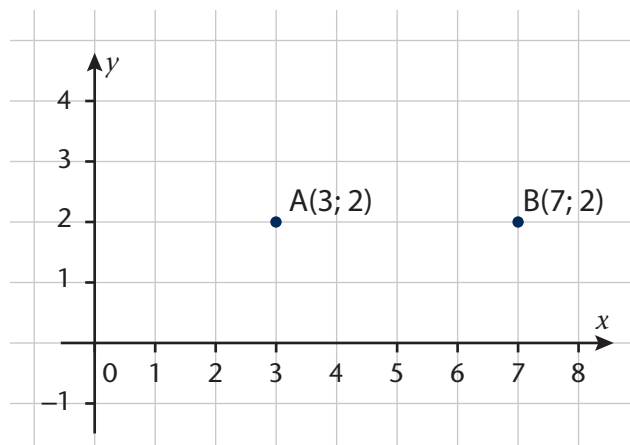

When we plot the points on the Cartesian plane, we realise that they are 4 units from each other. However, we can calculate the distance between the two points without first plotting them on the Cartesian plane.

Calculating the distance between the two points that have the same y -coordinate is equivalent to finding the difference between their x -coordinates. So, the distance between the points A and B is calculated as follows: $AB = 7 - 3 = 4$ units

Exercise

- 5 Now, consider the points given below and calculate the distances between them.
- (a) $C(-2; 3)$ and $D(4; 3)$
 - (b) $E(0; 4)$ and $F(4; 4)$
 - (c) $G(-2; -3)$ and $H(-5; -3)$
 - (d) $I(-10; 0)$ and $J(10; 0)$

Let us consider a different possibility to the one we have dealt with previously, where the two points have the same x -coordinate. Suppose we have points $U(3; 5)$ and $T(3; -2)$ and we want to find the distance between the two points.

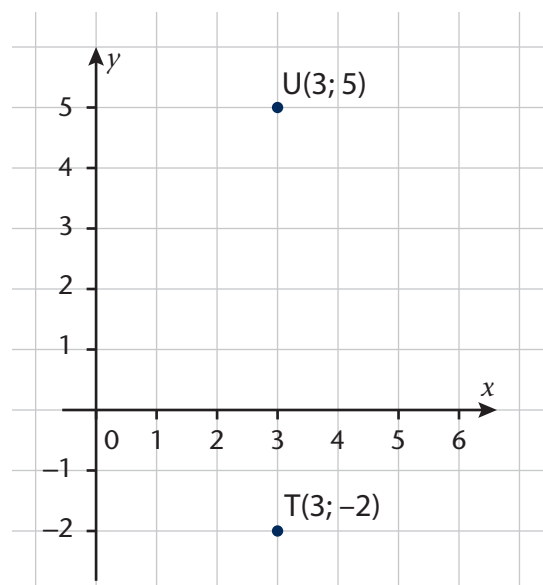

When considering points U and T on the Cartesian plane, we can see that the distance between the two points is 7 units.

Calculating the distance between the two points with the same x -coordinate is equivalent to finding the difference between their y -coordinates. So, the distance between the points U and T is calculated as follows:

$$UT = 5 - (-2) = 7 \text{ units}$$

or

$UT = -2 - 5 = -7$ but because we are calculating distance, we know by convention that we give the final answer as $UT = 7$ units.

Exercise

6 Now, consider the points given below and calculate the distances between them.

(a) $M(-2; 2)$ and $N(-2; -2)$

(b) $L(1; 0)$ and $P(1; -3)$

(c) $P(-4; -2)$ and $Q(-4; -15)$

(d) $R(0; -20)$ and $V(0; 30)$

The distance between any two points

Suppose we are given the points $E(-3; 1)$ and $D(3; 4)$, and we are required to calculate the distance between the two points. By drawing the line segments EC and CD along the grid lines, we form a right-angled triangle DCE , with ED being the hypotenuse.

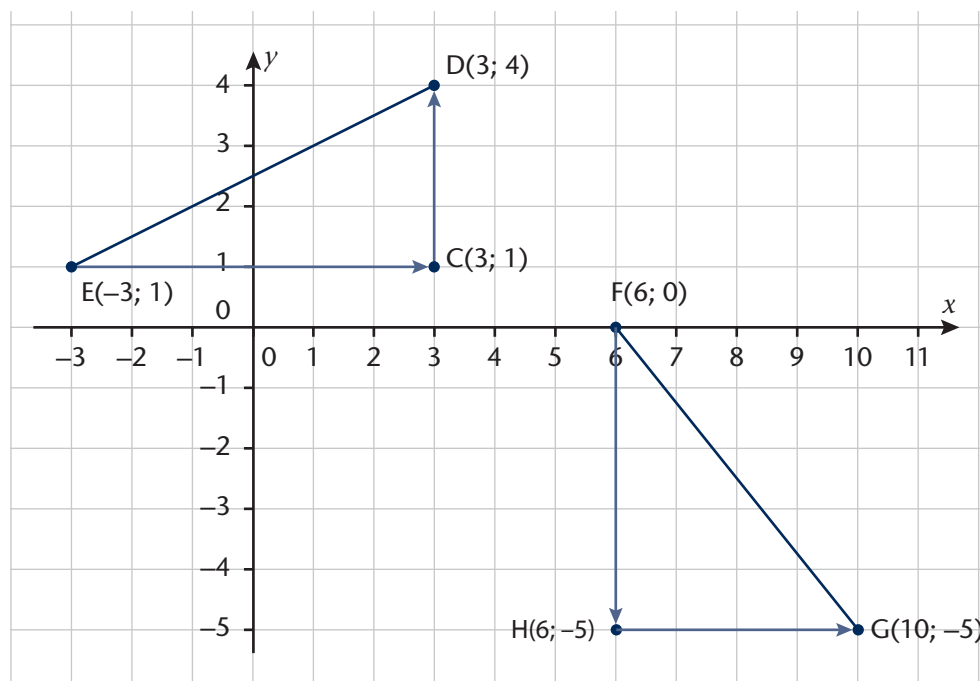

Worked examples

A. Problem: Consider the line segment ED in the previous diagram. The coordinates of point E are (-3; 1) and the coordinates of point D are (3; 4). What is the distance from point E to D?

Solution:

$$ED^2 = (3 - (-3))^2 + (4 - 1)^2$$
$$ED^2 = (6)^2 + (3)^2$$
$$ED^2 = 36 + 9$$
$$ED^2 = 45$$
$$\sqrt{ED^2} = \sqrt{45}$$
$$ED = \sqrt{45} \text{ units}$$

B. Problem: Consider the line segment FG in the previous diagram. The coordinates of point F are (6; 0) and the coordinates of point G are (10; -5). What is the distance between point F and G?

Solution:

$$FG^2 = (10 - 6)^2 + (-5 - 0)^2$$
$$FG^2 = (4)^2 + (5)^2$$
$$FG^2 = 16 + 25$$
$$FG^2 = 41$$
$$\sqrt{FG^2} = \sqrt{41}$$
$$FG = \sqrt{41} \text{ units}$$

Exercise

7 Consider the coordinates given in the Cartesian plane below:

A(0; -3), B(-2; 0), C(10; 5), D(3; 4), E(-3; 1) and G(9; -4)

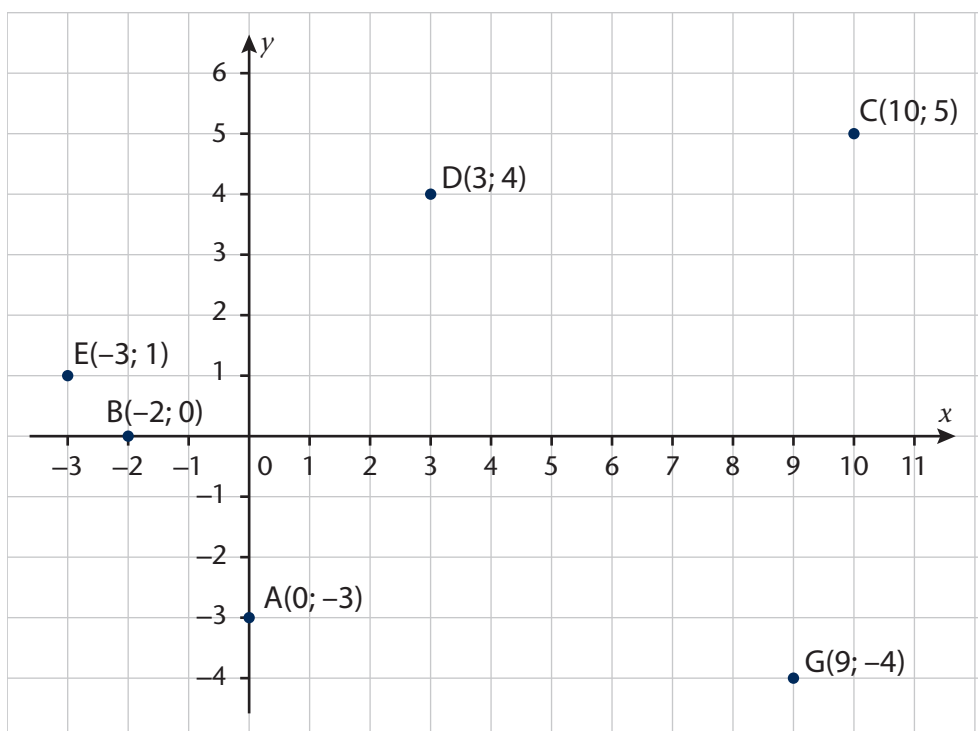

Calculate the lengths of the following line segments:

(a) AE

(b) BC

(c) DG

(d) AC

Distance formula: the general case

When calculating the distance between two points, or calculating the length of a line segment, much quicker without having to plot the coordinates of the points on a Cartesian plane, a formula can help us do that.

We will assume that our points have different x - and y -coordinates. We consider the right-angled triangle, ABC, shown below, with the length of $AB = y_B - y_A$ and the length of $BC = x_C - x_B$:

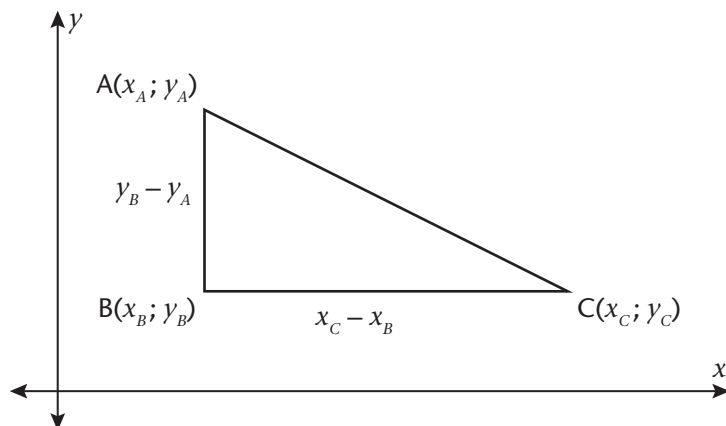

Then the length of AC, according to Pythagoras' Theorem, can be calculated as follows:

$$AC^2 = AB^2 + BC^2$$

$$AC^2 = (y_B - y_A)^2 + (x_C - x_B)^2$$

$$AC = \sqrt{(y_B - y_A)^2 + (x_C - x_B)^2}$$

Using this formula, we can now calculate the distance between two points without drawing a figure.

Worked example

Problem: Find the distance between the points A(4; 4) and B(-4; -4).

Solution: For the purpose of using the distance formula when calculating the distance between A and B, let A(4; 4) be the coordinates $(x_A; y_A)$ and B(-4; -4) be the coordinates $(x_B; y_B)$:

$$AB = \sqrt{(x_B - x_A)^2 + (y_B - y_A)^2}$$

$$AB = \sqrt{((-4) - (+4))^2 + (-4 - (+4))^2}$$

$$AB = \sqrt{(-8)^2 + (-8)^2}$$

$$AB = \sqrt{64 + 64}$$

$$AB = \sqrt{128}$$

Exercises

8 Find the distance between:

- (a) M(-4; 3) to U(3; 4) (b) U(1; 4) to S(2; 6)
(c) V(-3; -5) to H(0; 10) (d) P(9; -7) to H(-2; 1)

9 Calculate the distance between each pair of the following coordinates:

- (a) B(4; -1) and C(1; 3) (b) K(3; 0) and L(5; -4)
(c) N(0; 0) and O(10; 10) (d) S(1; -1) and T(-1; 1)

Proving properties of polygons

We can algebraically prove simple geometric theorems about polygons.

Worked example

Problem: Prove that $\triangle ABC$ with A(0; 0), B(2; 3) and C(4; 0) is an isosceles.

Solution: An isosceles triangle has two sides of equal length. To calculate the length of a straight line, we use the distance formula. We must show that the base sides of $\triangle ABC$ have the same length or distance.

$$\begin{array}{lll} AB = \sqrt{(3-0)^2 + (2-0)^2} & BC = \sqrt{(0-3)^2 + (4-2)^2} & AC = \sqrt{(0-0)^2 + (4-0)^2} \\ = \sqrt{3^2 + 2^2} & = \sqrt{(-3)^2 + (2)^2} & = \sqrt{0^2 + 4^2} \\ = \sqrt{13} & = \sqrt{13} & = \sqrt{16} \\ & & = 4 \end{array}$$

$$AB = BC = \sqrt{13}$$

So, we have just proven that $\triangle ABC$ is an isosceles triangle.

Exercises

10 Given that the vertices of $\triangle ABC$ are A(1; -6), B(5; -8) and C(7; -4):

- (a) Calculate the lengths of AB, BC, and AC.
(b) Is $\triangle ABC$ a right-angled triangle? Explain.

11 Use the distance formula to classify $\triangle ABC$ as one of the following: scalene, isosceles, equilateral, or right-angled triangle.

- (a) A(0; 4), B(-4; 0), C(4; 0)
(b) A(-3; -1), B(-5; -4), C(-2; -3)
(c) A(1; 1), B(4; 4), C(6; 2)

12 Prove that $D(3; -1)$, $E(4; 6)$ and $F(0; 3)$ are the vertices of an isosceles right-angled triangle.

13 (a) Prove that $P(-2; 2)$, $Q(-1; 6)$, $R(3; 7)$ and $S(2; 3)$ are the vertices of a rhombus.

(b) Can PQRS also be a parallelogram? Explain.

9.3 Midpoint coordinates of a line segment joining two points

The midpoint

The point M, halfway between the points A and B, is called the midpoint of the line segment AB.

The diagram below shows a number of points with different coordinates. Using the diagram below, we see that the coordinates of the midpoint of line segment AB is $M(0; 4)$.

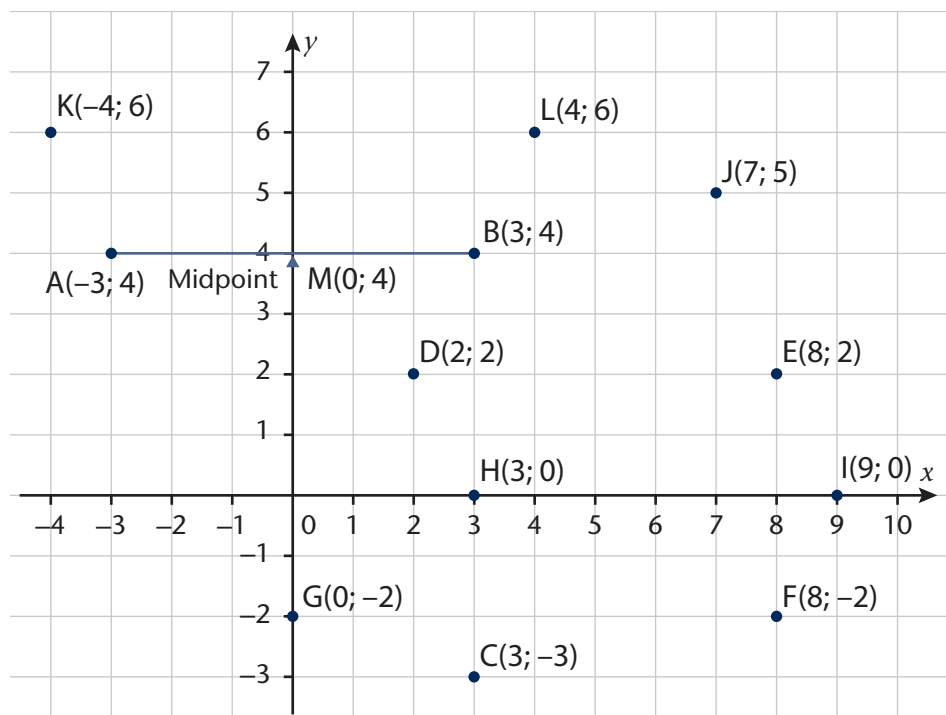

Exercise

14 Use the diagram above to find the coordinates of the midpoints of the following horizontal and vertical line segments:

(a) KL

(b) CH

(c) FE

(d) DE

(e) HI

(f) GF

In the previous exercise, we used the Cartesian plane to find the coordinates of the midpoints of line segments. We also want to be able to find the midpoint of any line segment, without necessarily drawing a diagram.

We define the x -coordinate and the y -coordinate of the midpoint of a line segment between two coordinate points, $(x_1; y_1)$ and $(x_2; y_2)$ to be:

$$x\text{-coordinate of } M = \frac{x\text{-coordinate of } A + x\text{-coordinate of } B}{2} \text{ and}$$

$$y\text{-coordinate of } M = \frac{y\text{-coordinate of } A + y\text{-coordinate of } B}{2}.$$

Therefore, the coordinates of a midpoint of a line segment can be calculated as $\left(\frac{x_1 + x_2}{2}; \frac{y_1 + y_2}{2}\right)$.

Worked example

Problem: Calculate the midpoint M , of the vertical line segment AB , where $A(-3; 4)$ and $B(3; 4)$.

Solution: x -coordinate of $M = \frac{-3 + 3}{2} = \frac{0}{2} = 0$

$$y\text{-coordinate of } M = \frac{4 + 4}{2} = \frac{8}{2} = 4$$

$$\text{So, } M\left(\frac{x_1 + x_2}{2}; \frac{y_1 + y_2}{2}\right) = M(0; 4)$$

Exercises

15 Now use the midpoint formula to calculate the midpoints of the line segments in exercise 14:

(a) KL

(b) CH

(c) FE

(d) DE

(e) HI

(f) GF

16 Use the midpoint formula to calculate the coordinates of the midpoints of the following line segments from the previous diagram:

(a) AK

(b) CG

(c) FJ

(d) DJ

(e) HE

(f) GE

17 Calculate the midpoint of the following line segments:

(a) CD where $C(5; -3)$ and $D(-5; 13)$

(b) AB where $A(-3; -1)$ and $B(0; 5)$

(c) EF where $E(-10; 10)$ and $F(10; -10)$

(d) GH where $G(7; 1)$ and $H(3; 0)$

18 Answer the questions below:

- (a) The midpoint of line segment CD is $(-4; 5)$. One endpoint of the line segment is $D(-5; 13)$. Calculate the coordinates of C.
- (b) The midpoint of line segment GH is $(5; \frac{1}{2})$. The coordinates of H are $(3; 0)$. Calculate the coordinates of G.
- (c) The midpoint of line segment is EF $(0; 0)$, where $E(-10; 10)$. Calculate the coordinates of F.
- (d) The midpoint of line segment AB is $(\frac{-3}{2}; 2)$. The coordinates of B are $(0; 5)$. Calculate the coordinates of A.

19 One of the properties of a parallelogram is that its diagonals bisect each other. Use this property to show that the coordinates $S(0; 3)$, $T(3; 5)$, $U(4; 9)$ and $V(1; 7)$ are the vertices of a parallelogram.

9.4 Gradient of a line segment

One of the most useful quantities that people such as scientists, artisans, engineers, and technicians often use is the gradient, also known as the slope. Roofers and carpenters, for example, use a level to determine the slope. The slope of a roof is called a pitch. In Chapter 6, you have done some work where you discussed the roof pitch.

When we design ramps, for example, the concept of slope becomes essential. Regulations provide that any ramp shall have a gradient, measured along the centre line, not steeper than 1:12. (How steep can ramps therefore be?)

We calculate the gradient of a straight line by choosing any two points on the line, for instance $A(x_1; y_1)$ and $B(x_2; y_2)$. We do this because we know that for a straight line the gradient is constant.

We define the **gradient** (m) of a line between two points, as the ratio of the change in the value of y to the change in the value of x , and we write that in fraction form as shown below:

$$m_{AB} = \frac{y_2 - y_1}{x_2 - x_1} = \frac{\text{change in the value of } y}{\text{change in the value of } x}$$

Worked example

Problem: Find the gradient of the line through the points C(-3; 3) and F(6; -2).

Solution: Let $(x_1; y_1)$ be (-3; 3) and $(x_2; y_2)$ be (6; -2)

$$m_{CF} = \frac{y_2 - y_1}{x_2 - x_1} = \frac{(-2) - (3)}{(6) - (-3)} = \frac{-5}{9}$$

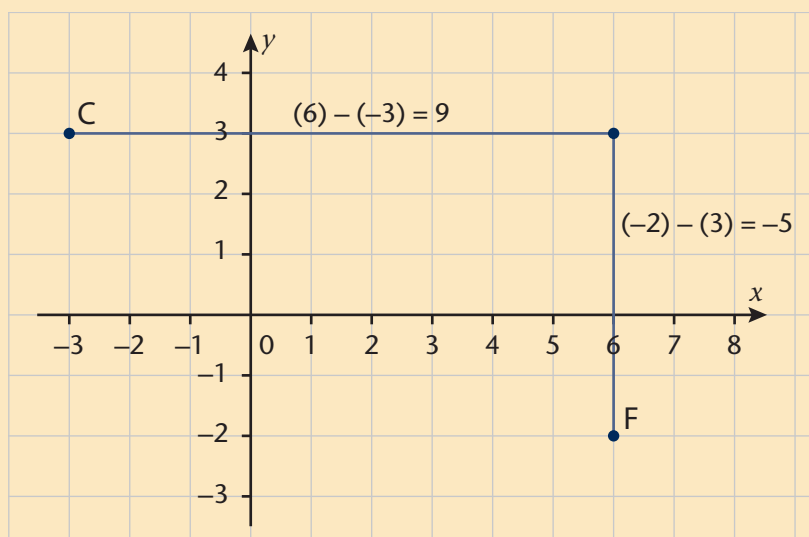

Exercises

- 20 Calculate the gradients of the lines passing through the following pairs of points. First, plot each pair of points on the Cartesian plane. Use the same plane to plot all the points given below.
- (a) C and D, where C(5; -3) and D(-5; 13)
 - (b) A and B, where A(-3; -1) and B(0; 5)
 - (c) E and F, where E(-10; 10) and F(10; -10)
 - (d) G and H, where G(7; 1) and H(3; 0)
- 21 Calculate the gradients of the straight lines through the following sets of points.
- (a) A(2; 0) and B(-1; 1)
 - (b) C(12; 13) and D(6; 7)
 - (c) E(-3; -5) and F(3; 5)
 - (d) G(-9; -3) and H(-3; -9)

Parallel lines

We can use our knowledge of the gradient to determine the relationship between lines, that is, whether lines are parallel to each other, or perpendicular to each other, or neither parallel nor perpendicular to each other. Two lines are parallel if and only if:

- their slopes (gradients) are equal and they also do not lie on top of each other
- both lines are vertical (their gradients are undefined) and they do not lie on top of each other

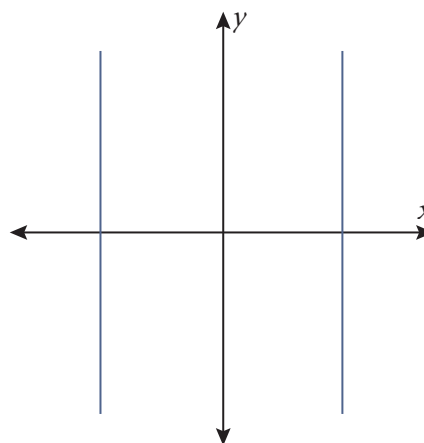
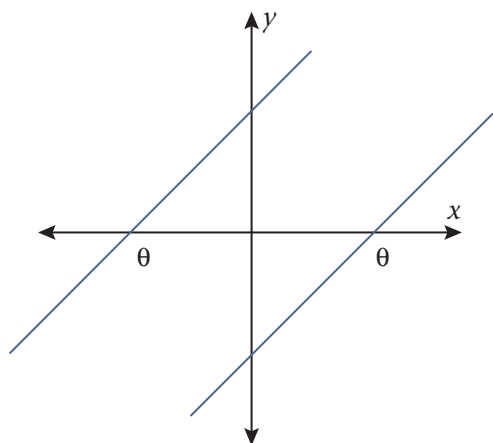

Worked examples

A. Problem: What is the gradient of the line parallel to a line with a gradient of 5?

Solution: Parallel lines have equal gradients, so the gradient of a line parallel to the given line will also be 5.

B. Problem: A straight line passes through the points A(0; 2) and B(3; 5). Another straight line passes through points C(13; 13) and D(0;0). Are the two lines parallel to each other?

Solution: $m_{AB} = \frac{5 - 2}{3 - 0} = \frac{3}{3} = 1$
 $m_{CD} = \frac{0 - 13}{0 - 13} = \frac{-13}{-13} = 1$

The gradients of the two lines are equal, so the lines are parallel.

Exercises

- 22 Which of the straight lines passing through each pair of points given below will be parallel?
- A(2; 0) and B(-1; 1); C(12; 13) and D(6; 7)
 - E(-3; -5) and F(3; 5); G(-9; -3) and H(-3; -9)
 - K(0; 0) and L(5; 10); P(0; 1) and Q(5; 9)

(d) R(1; -1) and S(3; -3); T(10; -9) and U(30; -29)

(e) I(-5; 0) and J(0; 5); L(0; 5) and N(5; 0)

(f) V(2; 0) and W(2; 22); P(0; 10) and T(0; -3)

23 What is the gradient of a line parallel to the line with a gradient of:

(a) -3

(b) $\frac{2}{5}$

(c) $\frac{5}{2}$

(d) 1,8

(e) -0,6

24 One of the properties of a parallelogram is that it has two pairs of parallel sides. Use this property to show that the coordinates S(0; 3), T(3; 5), U(4; 9) and V(1; 7) are the vertices of a parallelogram.

Perpendicular lines

Two lines are perpendicular to each other if and only if:

- the product of their gradients is -1
- one line is horizontal (gradient = 0) and the other line vertical (gradient undefined)

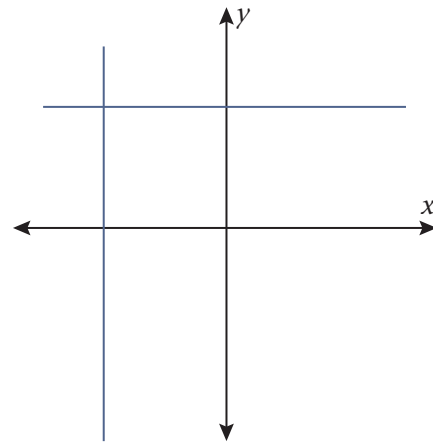
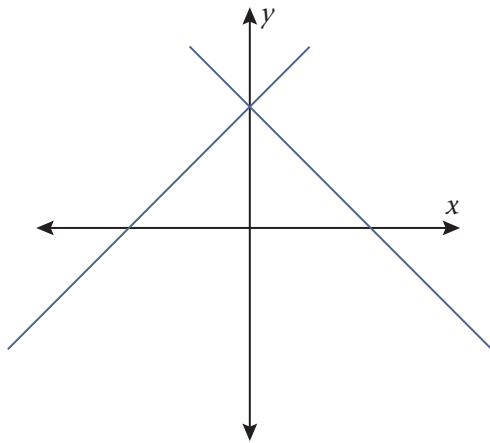

Determining the gradient of a perpendicular line can be done mentally.

Gradient of one line	Gradient of the line perpendicular to it	Product of gradients
$m = 3$	$m = -\frac{1}{3}$	-1
$m = -3$	$m = \frac{1}{3}$	-1
$m = \frac{3}{5}$	$m = -\frac{5}{3}$	-1
$m = -\frac{1}{2}$	$m = 2$	-1

Worked example

Problem: What is the gradient of the line perpendicular to a line with a gradient of 5?

Solution: The product of gradients of perpendicular lines is -1 . So, the gradient of the other line must be $-\frac{1}{5}$ because $5 \times -\frac{1}{5} = -1$.

Exercise

25 Determine the gradients of the lines that are perpendicular to lines with the following gradients:

- | | |
|-------------------|--------------------|
| (a) 10 | (b) -10 |
| (c) $\frac{3}{4}$ | (d) $\frac{-3}{2}$ |
| (e) -1 | (f) 0 |
| (g) undefined | |

Worked example

Problem: A straight line passes through the points A(1; 2) and B(3; 8). Another straight line passes through points C (5; 5) and D(-4; 8). Are the two lines perpendicular to each other?

Solution: $m_{AB} = \frac{(8) - (2)}{(3) - (1)} = \frac{6}{2} = 3$

$$m_{CD} = \frac{(8) - (5)}{(-4) - (5)} = -\frac{3}{9} = -\frac{1}{3}$$

Because $m_{AB} \times m_{CD} = 3 \times -\frac{1}{3} = -1$, the product of the gradients of the two lines is -1 .

Therefore, the lines are perpendicular to each other.

Exercises

- 26 A quadrilateral has vertices at the points A(-3; 1), B(-1; 4), C(3; 7) and D(5; -2).
- Calculate the gradients of the diagonals AC and BD.
 - What can you say about the diagonals of the quadrilateral ABCD?
 - What type of a quadrilateral is ABCD? Explain.
- 27 Now, consider a quadrilateral with vertices of O(0; 0), P(2; 4), Q(4; 4) and R(4; 2). One of the properties of a kite is that one diagonal is the perpendicular bisect of the other. Show that this property applies to this quadrilateral.
- 28 Another quadrilateral has vertices at the points M(0; 2), N(1; 0), P(7; 3) and V(4; 4). What type of a quadrilateral is this?

9.5 Equation of a straight line passing through two points

In this section, we will learn about the equations of straight lines passing through two points. The equation of a line can take different forms, depending on some of the information we are given about a line.

We know that the gradient of a straight line is given by:

$$m = \frac{\text{change in the value of } y}{\text{change in the value of } x} = \frac{y_2 - y_1}{x_2 - x_1}$$

On any straight line, the gradient between collinear points will be constant. Therefore, the equation of the gradients is given by:

$$y - y_1 = m(x - x_1), \text{ or } y - y_1 = \frac{y_2 - y_1}{x_2 - x_1}(x - x_1), \text{ or } y = mx + c$$

Worked example

Problem: A straight line passes through the points A(0; 2) and B(3; 5). What is the equation of the straight line that passes through the points?

Solution:

$$\begin{array}{lll} y - y_1 = m(x - x_1) & y - y_1 = \frac{y_2 - y_1}{x_2 - x_1}(x - x_1) & y = mx + c \\ m_{AB} = \frac{2 - 5}{0 - 3} = \frac{-3}{-3} = 1 & y - 5 = \frac{2 - 5}{0 - 3}(x - 3) & m_{AB} = \frac{2 - 5}{0 - 3} = \frac{-3}{-3} = 1 \\ y - 5 = 1(x - 3) & \text{or } y - 5 = 1(x - 3) & \text{or } y = 1x + c \\ y - 5 = x - 3 & & 3 = 1(5) + c \\ y = x + 2 & & 3 = 5 + c \\ & & c = 2 \\ & & y = x + 2 \end{array}$$

Exercise

29 Determine the equation of the straight line through:

- (a) A(-7; -7) and B(7; 7)
- (b) C(4; 0) and D(-4; 0)
- (c) E(0; 4) and F(0; -4)
- (d) G(3; 6) and H(-1; -2)
- (e) I(6; 3) and J(-2; -1)
- (f) K($\frac{1}{2}$; 1) and L(-3; 6)

9.6 Summary

- In this chapter, you learnt to represent geometric figures on a Cartesian coordinate system and apply formulae to determine distances between points, midpoint of line segments, gradient of line segments connecting two points, and the equation of a straight line passing through a set point.
- The x -coordinate is the value that tells us where the point lies in relation to the x -axis, and the y -coordinate is the value that tells us where a point lies in relation to the y -axis.
- To calculate the distance between two points $(x_1; y_1)$ and $(x_2; y_2)$ we use the **distance formula** as follows: $d = \sqrt{(y_2 - y_1)^2 + (x_2 - x_1)^2}$.
- To find the midpoint of any line segment between two coordinate points, $(x_1; y_1)$ and $(x_2; y_2)$ without drawing a diagram, we can use the **midpoint formula** as follows:

$$m\left(\frac{x_1 + x_2}{2}, \frac{y_1 + y_2}{2}\right).$$

- The **gradient (m)** of a straight line between two coordinate points indicates the slope of the line and whether it is a positive (increasing) or negative (decreasing) slope. We use the following formula to calculate the gradient of a straight line between the points $(x_1; y_1)$ and $(x_2; y_2)$: $m = \frac{y_2 - y_1}{x_2 - x_1}$.
- The formula for a **straight line** through two points $(x_1; y_1)$ and $(x_2; y_2)$ can be given by:
 $y - y_1 = m(x - x_1)$ **or** $y - y_1 = \frac{y_2 - y_1}{x_2 - x_1}(x - x_1)$ **or** $y = mx + c$.
- All **horizontal lines** have equations of the form $y = c$, where c is a constant. The gradient of a horizontal line is 0.
- All **vertical lines** have equations of the form $x = a$ number. The gradient of a vertical line is undefined.

9.7 Consolidation exercises

- Given the points $A(4; -4)$ and $B(-3; 4)$. Calculate:
 - the length of line segment AB
 - the midpoint of line segment AB
 - the gradient of line segment AB
- The $\triangle ABC$ has coordinates $A(3; 10)$, $B(2; 3)$ and $C(10; 9)$ as shown below:

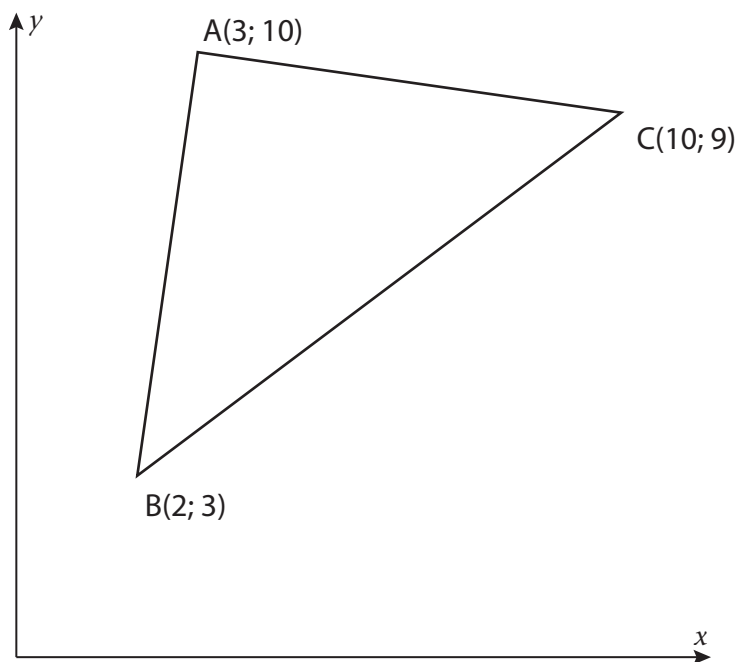

- Calculate the lengths of AB, AC, and BC.
 - What sort of triangle is ABC?
 - Find the midpoint, M, of BC.
 - Calculate the gradient of AM.
- The quadrilateral STQR has vertices $S(5; -1)$, $T(-2; -3)$, $Q(0; 5)$ and $R(7; 7)$.
 - Calculate the lengths of the sides ST, TQ, QR and RS.
 - Calculate the gradients SR, TQ, ST and QR.
 - Calculate the midpoints SR, TQ, ST and QR.
 - What type of quadrilateral could STQR be?

-
- 4 Draw straight line graphs on the same system of axes and discuss the gradient in relation to the shape of the graphs:
- | | |
|------------------|-------------------|
| (a) $y = 6x + 3$ | (b) $y = -3x + 6$ |
| (c) $y = 6$ | (d) $x = 3$ |
| (e) $y = 3x$ | (f) $y = -5x - 3$ |
- 5 Calculate the value of k given that the line joining:
- (a) R(0; 4) to Q(3; k) has a gradient of 2.
 - (b) A(-3; k) to B(-1; -3) has a gradient -4.
- 6 The endpoints of line segment ST are S(8; 1) and T(6; c). The midpoint of ST is M(d ; -3). Calculate the values of c and d .
- 7 M is the midpoint of AB. Calculate the coordinates of B, if A is (3;1) and M is (10; -3).

10 CIRCLES, ANGLES, AND ANGULAR MOVEMENT

So far, you have used degrees to measure angles.

In this chapter, you will learn:

- how to measure angles using radians
- find the arc length of a circle
- convert between degrees and radians
- convert between decimals and degree-minute-second forms of angles

10.1 Preparing

Parts of the circle:

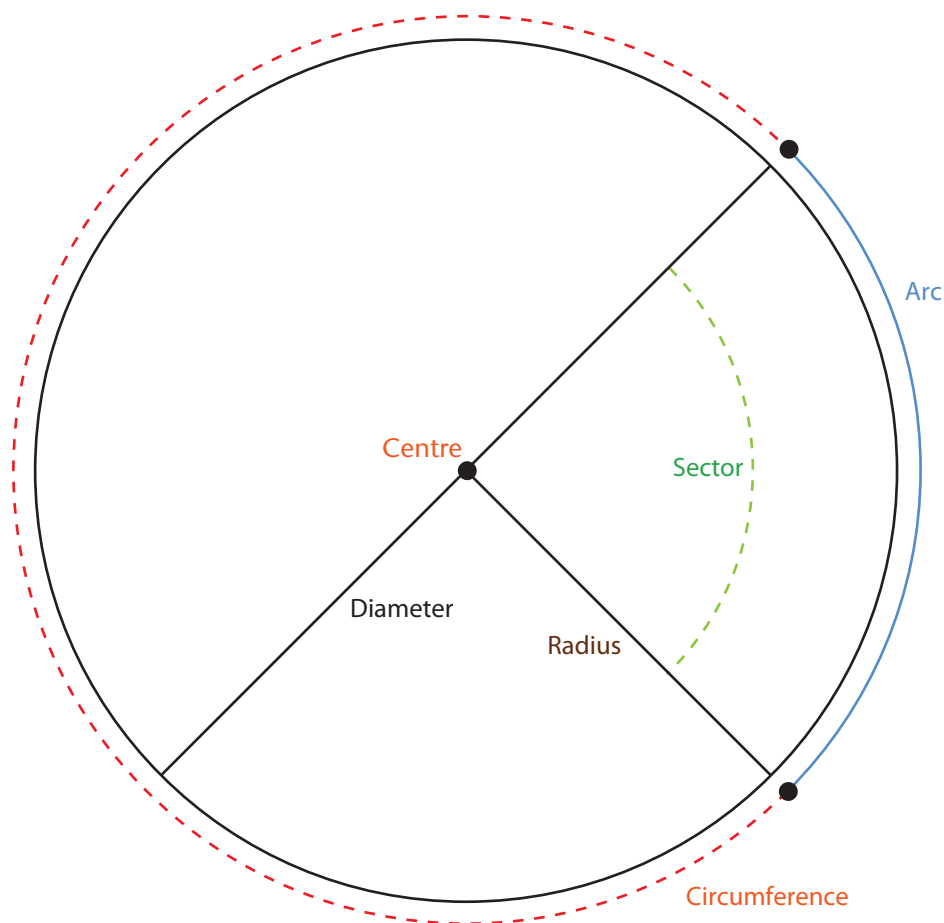

Circumference	The length around the entire edge of a circle is called the circumference. The length of the circumference of a circle is equal to the radius of the circle multiplied by twice the value of π ($C = 2\pi r$ or $D\pi$).
Diameter	A straight line from one point on the circumference of a circle through the centre to the opposite point on the circumference is called a diameter.
Radius	A line segment joining the centre of a circle to a point on the circle is called a radius. The diameter is twice the length of the radius of a circle.
Arc	Part of the circumference of a circle is called an arc.
Sector	Part of a circle enclosed by two radii of a circle and their intercepted arc, a pie-shaped part of a circle.
Central angle	A central angle is a positive angle whose vertex is at the centre of a circle.
Standard position of an angle	We measure angles on a circle starting at the positive horizontal axis and moving anti-clockwise unless instructed otherwise.

10.2 Revisiting π (π)

π is used in many mathematical calculations. In the previous grades you have talked about and used π when you did calculations involving circles. You may only have been told that the value of π is 3,14 or $\frac{22}{7}$ when expressed as a fraction. The exercise below is intended to help you get a better understanding of this number called π .

Exercises

- Using different objects with circular cross sections (such as a can, CD, etc.), take a piece of string and carefully measure out the diameter and circumference of each of the circular cross sections of these objects. Straightening out the string alongside a ruler, determine the length as measured with the string. Record your results in the appropriate columns. Use your calculator to calculate the ratio, *circumference: diameter* $\left(\frac{\text{circumference}}{\text{diameter}}\right)$ and record the results in the last column. Try to be as accurate as is humanly possible, however, your results may not be exact, as you will not be using precise measuring tools.
 - Copy the table in your exercise book and then follow the instructions given below:

Circle	Radius (cm)	diameter	circumference	$\frac{\text{circumference}}{\text{diameter}}$
A	3			
B	4			
C	5			
D	6			
E	7			
F	8			
G	9			

Instructions for measuring the circumference and the diameter:

- Take a piece of string and place the end of the string on top of the circle. Wrap the string around the entire circle's perimeter (circumference).
- Mark the point on the string where it meets the end of the string at the top of the circle.

- Pick up the string after you have marked it, straighten it out, and cut it off where you marked it. This gives you the perimeter (circumference) of the circle.
- Measure (in centimetres) the piece of string with a ruler.

The ratio of the circumference of a circle to its diameter is called **π** (π).

$$\pi = \frac{\text{circumference}}{\text{diameter}} \text{ is a constant ratio.}$$

- (c) What can you say about the calculated values of $\frac{\text{circumference}}{\text{diameter}}$ for the three circles?
- (d) Calculate the average value for the values in the $\frac{\text{circumference}}{\text{diameter}}$ column.
- (e) Is the value of π dependent on the size of the circle? Explain.

Properties that stay the same when other attributes change are said to be **constant**.

2 We can use the formulae $C = \pi d$ or $C = 2\pi r$ to calculate the circumference of a circle.

- (a) Make π the subject of the formula in each formula.
- (b) Use your formulae to calculate the value of π for each of the following cases:

(i) $C = 15,71; r = 2,5$

(ii) $C = 83,6; r = 13,3$

(iii) $C = 53,7; d = 17,1$

(iv) $C = 62,8; d = 20$

The following formulae relate the circumference, diameter, and radius of a circle:

$$\text{diameter} = 2 \times \text{radius}$$

$$\text{circumference} = 2\pi r \text{ or } D\pi$$

- (c) How close are the values of π you have calculated in exercise 2(b) above, to the ones you calculated in exercise 1?

3 Use $\pi = 3,14$ in your calculations.

- (a) What is the circumference of a wheel with a diameter of 60 cm?
- (b) The radius of a circle is 3 cm. Calculate its circumference.
- (c) If you walk all the way around the outside of a circular sports field with a radius of 50 metres, how far have you walked?
- (d) You have to cut a rubber tubing to cover a rod that will be bent into a circular shape with a diameter of 1 500 mm. How much rubber should you cut?

10.3 Measuring angles: Degrees ($^{\circ}$)

You have measured angles in the previous grades using turns, revolutions, and degrees. You have probably also learned that a revolution has a measure of 360° .

Exercises

- 4 Divide a circle into an equal number of sectors, as indicated in the table below. Copy and complete the table.

	Number of equal sectors	The angle of each sector		Number of equal sectors	The angle of each sector
(a)	2		(g)	20	
(b)	4		(h)	30	
(c)	5		(i)	40	
(d)	6		(j)	90	
(e)	9		(k)	120	
(f)	12		(l)	360	

- 5 (a) Copy and complete the table below.

Words	Number of revolutions	Number of degrees
No turn	0	
Quarter turn		
Half turn		
Three-quarter turn		
Full turn		
Twelfth turn		
Eight turn		
Sixth turn		
Fifth turn		

- (b) How do we convert from revolutions to degrees?

From exercise 4, we can deduce that an angle of 1° is equal to $\frac{1}{360}$ (one three hundred and sixtieth) of a revolution.

In this section we will learn how to subdivide a degree using

- decimal notation
- minutes and seconds

An angle of 1° is equivalent to 60 minutes. We represent 60 minutes as $60'$.

$$1^\circ = 60'$$

So, 1 minute, written as $1'$, is equivalent to $\frac{1}{60}$ (one sixtieth) of an angle of 1° .

There are 60 seconds in a minute. We represent 60 seconds as $60''$.

One second ($1''$) is $\frac{1}{60}$ (one sixtieth) of a minute and $\frac{1}{3\,600}$ (one three thousand six hundredth) of an angle of 1° .

Worked example Converting decimal degree notation to degree-minute-second notation

Problem: Convert $130,831^\circ$ to degree-minute-second.

Solution:

Multiply 0,831 by 60 to get 49,89'

$$130,831^\circ = 130^\circ + (0,831 \times 60)$$

$$= 130^\circ + 49,86'$$

Multiply 0,86' by 60 to get 52''

$$= 130^\circ + 49' + (0,86' \times 60)$$

$$= 130^\circ 49' 52''$$

Exercise

6 Convert each angle to degree-minute-second form.

(a) $120,534^\circ$

(b) $97,568^\circ$

(c) $33,234^\circ$

(d) $40,987^\circ$

(e) $238,123^\circ$

(f) 3031303°

(g) $107,5^\circ$

(h) $342,05^\circ$

Worked example Converting from degree-minute-second notation to decimal degree notation

Problem: Write $28^{\circ}45'33''$ in terms of degrees only.

$28^{\circ}45'33''$ is a short way of writing 28 degrees, 45 minutes, and 33 seconds.

Solution: $28^{\circ}45'33'' = \left(28 + \frac{45}{60} + \frac{33}{3\,600}\right)^{\circ} \approx 28,759^{\circ}$

Exercise

7 Convert each angle to decimal degrees. Give answers correct to three decimal places.

(a) $100^{\circ}11'30''$

(b) $89^{\circ}60'60''$

(c) $203^{\circ}89'$

(d) $28^{\circ}14'45''$

(e) $302^{\circ}23'44''$

Using a calculator

We can also use a calculator to convert between decimal degrees and the degree-minute-second equivalent.

See if you can find the button on your calculator that can be used to convert between decimal degrees and degree-minute-second.

Exercises

8 Do exercise 6 again, but now use your calculator.

9 Do exercise 7 again, but now use your calculator.

Radian measure (rad)

In this section, you will learn about another unit for measuring angles, called the radian. The idea is to measure the length of an arc, subtended by an angle centred at its vertex.

The exercise below is aimed at assisting you to make sense of this unit of measurement.

Concentric circles are circles with the same centre but different radii.

Exercise

10 Consider the concentric circles:

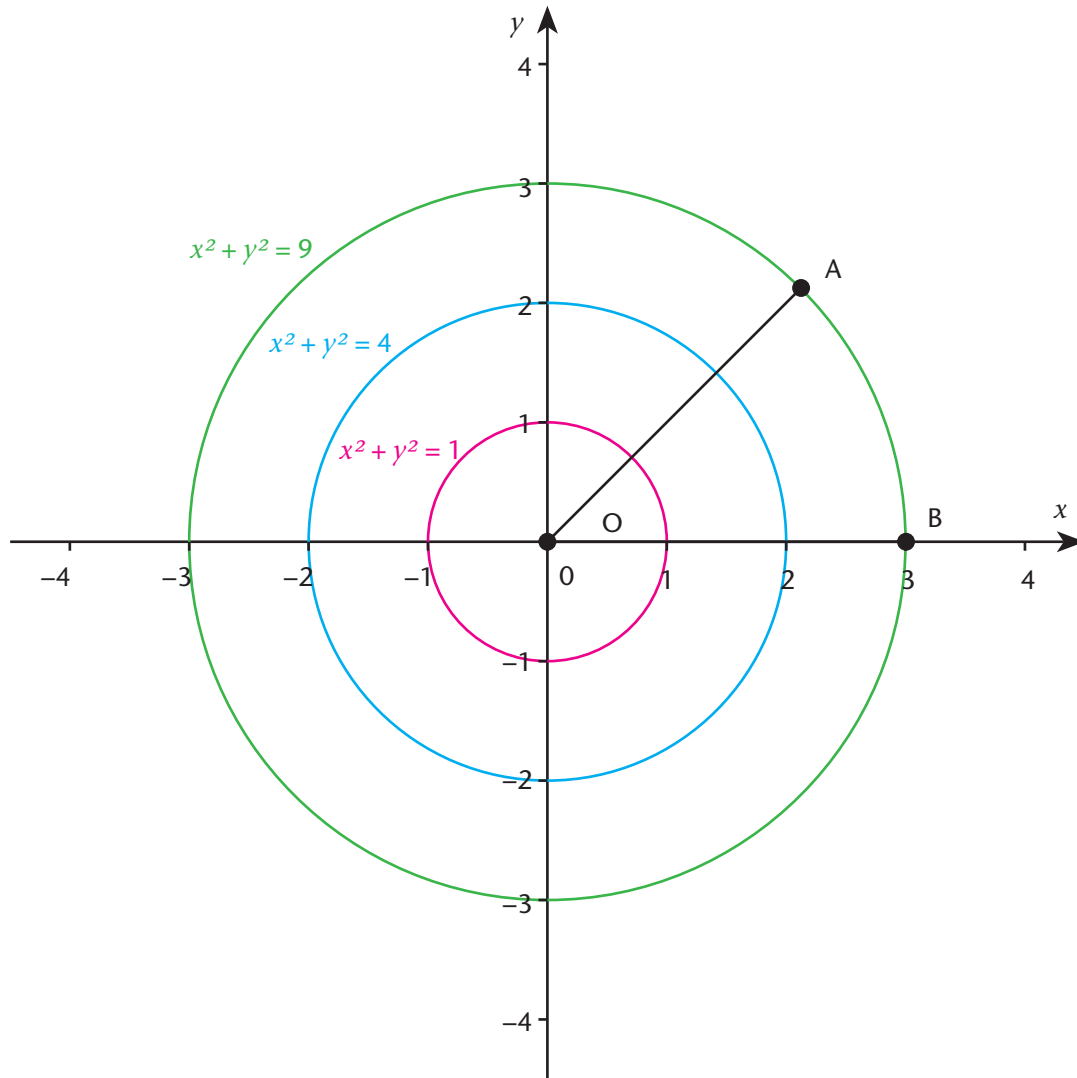

Let us examine the radius, arc, and central angle of the concentric circles above.

- Use an appropriate instrument and measure the radius of all three circles. Record the values in the table below.
- With the same instrument, measure the length of each arc subtended by the central angle \hat{AOB} for each circle. Copy the table in your exercise book and record the measurements in the table.

circle	radius	circumference	$\frac{\text{radius}}{\text{circumference}}$	arc length	$\frac{\text{arc length}}{\text{radius}}$
Red					
Blue					
Green					

- (c) Calculate the values for the last column.
- (d) Write down what you observe about:
- the relationship between the radius and the arc length;
 - the ratio between the arc length and the radius.
- (e) Estimate the size of the central angle without measuring it?
- (f) Measure the size of the central angle with your protractor. What do you observe?

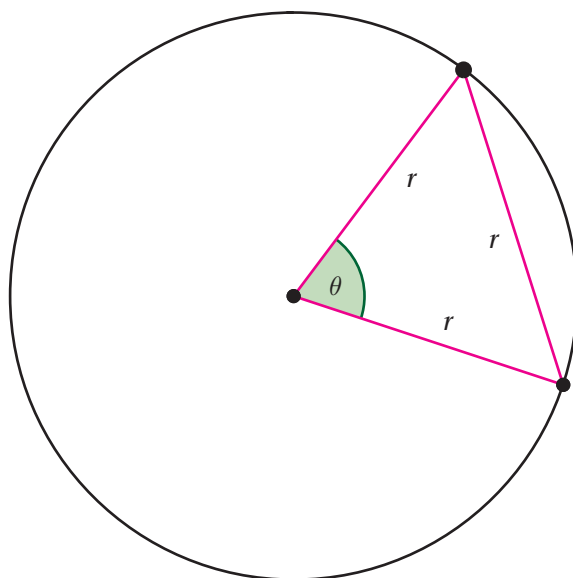

Defining a radian

We can think of a **radian** as the measure of a central angle that subtends an arc with a length equal to the circle's radius.

The ratio of the arc length to the radius of the circle:

- Angle (θ) = $\frac{\text{arc length } (s)}{\text{radius } (r)}$ (s and r must be expressed in the same unit).
- Algebraically we write $\theta = \frac{s}{r}$ where θ is in radians.
- The number of radii one can fit into a certain arc.

Worked example

Problem: What is the measure (in radians) of a central angle (θ) that intercepts an arc of length 2 cm on a circle with a radius 5 cm?

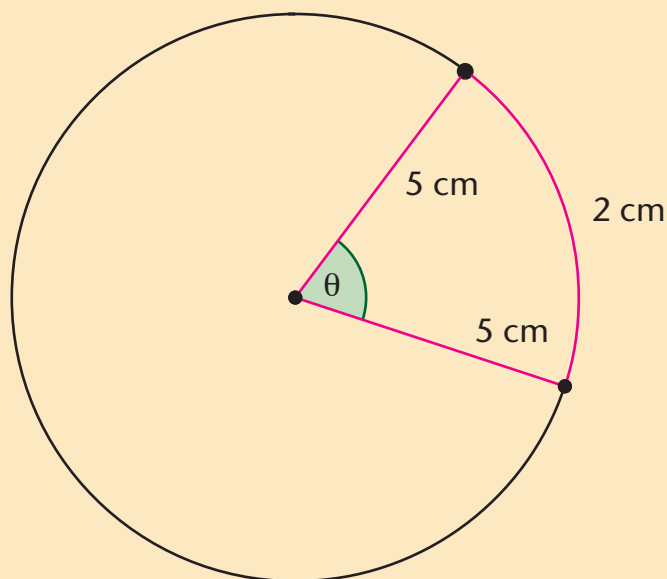

Solution: $\text{angle } (\theta) = \frac{\text{arc length } (s)}{\text{radius } (r)}$

$$\theta = \frac{s}{r}$$

$$\theta = \frac{2 \text{ cm}}{5 \text{ cm}} = 0,4 \text{ rad}$$

Exercise

- 11 In each case, find the measure of a central angle that intercepts an arc.
- What is the measure (in radians) of a central angle θ that intercepts an arc of length 10 cm on a circle with radius 5 cm?
 - What is the measure (in radians) of a central angle θ that intercepts an arc of length 30 cm on a circle with radius 5 cm?
 - What is the measure (in radians) of a central angle θ that intercepts an arc of length 10 cm on a circle with radius 4 cm?
 - What is the measure (in radians) of a central angle θ that intercepts an arc of length 16 cm on a circle with radius 4 cm?
 - What is the measure (in radians) of a central angle θ that intercepts an arc of length 40 cm on a circle with radius 40 cm?

10.4 Converting from degrees to radians

If we want to convert from degrees to radians or from radians to degrees, we can use a unit conversion factor.

We read 2π rad as 2π radians. What we mean by this is that there are 2π radians in a revolution. We may express the above statement as: 2π rad = 360° .

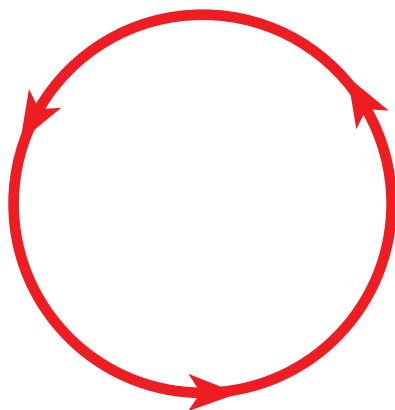

We know that the circumference of a circle is calculated using the formula $C = 2\pi r$.

We also know that the circumference is the same as the full length of the entire arc of the circle, which equals one revolution.

The equivalent degrees of 1 radian, is:

$$1 \text{ rad} = \frac{360^\circ}{2\pi} = \frac{180^\circ}{\pi} = 57,296^\circ$$

The equivalent radian of 1 degree is:

$$1^\circ = \frac{2\pi}{360^\circ} = \frac{\pi}{180^\circ} \text{ rad}$$

To convert from radians to degrees we multiply radians by	To convert from degrees to radians we multiply degrees by
$\frac{180^\circ}{\pi}$	$\frac{\pi}{180^\circ}$

Worked examples

A. **Problem:** Express $\frac{2\pi}{3}$ in terms of degrees.

$$\begin{aligned} \text{Solution: } \frac{2\pi}{3} &= \frac{2\pi}{3} \times \frac{180^\circ}{\pi} \\ &= 120^\circ \end{aligned}$$

B. **Problem:** Convert 20° to radians

$$\text{Solution: } 20^\circ = 20^\circ \times \frac{\pi}{180^\circ} = \frac{\pi}{9} \text{ rad}$$

Exercises

12 Rewrite the following angles in degrees (do not use a calculator).

- | | | | |
|-----------------------|-----------------------|------------------------|------------------------|
| (a) $\frac{7\pi}{4}$ | (b) $\frac{9\pi}{12}$ | (c) $\frac{\pi}{90}$ | (d) 4π |
| (e) 2π | (f) π | (g) $\frac{3\pi}{4}$ | (h) $\frac{11\pi}{18}$ |
| (i) $\frac{\pi}{2}$ | (j) $\frac{3\pi}{5}$ | (k) $\frac{4\pi}{15}$ | (l) $\frac{6\pi}{5}$ |
| (m) $\frac{7\pi}{10}$ | (n) $\frac{\pi}{9}$ | (o) $\frac{13\pi}{12}$ | |

13 Rewrite the following angles in radians (do not use a calculator).

- | | | | |
|-----------------|-----------------|-----------------|-----------------|
| (a) 30° | (b) 150° | (c) 310° | (d) 105° |
| (e) 45° | (f) 180° | (g) 330° | (h) 12° |
| (i) 60° | (j) 210° | (k) 345° | (l) 78° |
| (m) 75° | (n) 225° | (o) 157° | (p) 94° |
| (q) 120° | (r) 240° | (s) 0° | (t) 131° |

14 Copy and complete the table of equivalent angle measures.

Degree measure	0°	1°	(c)
Radian measure	(a)	(b)	1 rad

15 Copy and complete the table below, filling in the equivalent radian values.

Multiples of 30° and $\frac{\pi}{6}$		Multiples of 45° and $\frac{\pi}{4}$		Multiples of 60° and $\frac{\pi}{3}$		Multiples of 90° and $\frac{\pi}{2}$	
degree	radian	degree	radian	degree	radian	degree	radian
30°		45°		60°		90°	
60°		90°		120°		180°	
90°		135°		180°		270°	
120°		180°		240°		360°	
150°		225°		300°			
180°		270°		360°			
210°		315°					
240°		360°					
270°							
300°							
330°							
360°							

16 Add the following and give the answers in degrees:

- (a) $\frac{\pi}{4} + \pi + \frac{2\pi}{3}$ (b) $2\pi - \frac{5\pi}{4}$ (c) $\frac{\pi}{6} + \frac{\pi}{3} + \frac{\pi}{2} + \frac{\pi}{4}$
 (d) $\frac{11\pi}{18} + \frac{\pi}{9}$ (e) $\frac{5\pi}{4} + 30^\circ$ (f) $45^\circ + \frac{\pi}{4}$
 (g) $2\pi - \frac{\pi}{9} - 120^\circ$ (h) $\pi - 140^\circ + 80^\circ$ (i) $\frac{\pi}{2} - \frac{\pi}{3}$

17 Calculate or simplify the following without use of a calculator:

- (a) $\sin \frac{\pi}{2} + \cos \frac{\pi}{4}$ (b) $\tan \frac{\pi}{4} - 1$
 (c) $\cos \frac{\pi}{2} - \cos \frac{\pi}{3}$ (d) $\sin 45^\circ = \tan \frac{3\pi}{4}$
 (e) $\cos 0^\circ + \sin \frac{3\pi}{2} - \tan \frac{5\pi}{4}$

18 Determine the value of the following (answers must be given in radians):

- (a) $\sin^{-1}(0,5) + \cos^{-1}(0,866) + \tan^{-1}(0,577)$ (b) $\sin^{-1}(\frac{1}{\sqrt{2}}) + \tan^{-1}(-1) + \cos^{-1}(0)$
 (c) $\cos^{-1}(-1) - \sin^{-1}(-1)$ (d) $\tan^{-1}(1) - \sin^{-1}(1)$

19 Complete these conversions:

Revolution	Degree	Radian	Rough sketch
1			
	180°		
	32°		
$\frac{1}{4}$			
		$\frac{2\pi}{3}$	
$\frac{1}{12}$			
	40°		
$\frac{1}{6}$			

20 Complete the following practical investigations:

- (a) Two gears are rotating. The smaller gear has a radius of 10 cm and the larger gear's radius is 18 cm. What is the angle through which the larger gear has rotated when the smaller gear has made one complete revolution?
 (b) A smaller gear and a larger gear are meshed. An 80° rotation of the small gear causes the larger gear to rotate through 50°. Find the radius of the larger gear if the smaller gear has a radius of 11,7 cm.

- (c) Calculate the angle in radians through which a pulley with a diameter of 0,6 m moves if a length of belt of 120 m passes over the pulley.
- (d) A road wheel with a diameter of 5 600 mm turns through an angle of 150° . Calculate the distance moved by a point on the tyre thread of the wheel.
- (e) Find the radius of the pulley if a rotation of $51,16^\circ$ raises the weight 15,4 cm.
- (f) A rope is being wound around a drum with radius 0,3 metres. How much rope will be wound around the drum if the drum is rotated through an angle of $39,72^\circ$?
- (g) A circle has a radius 20 cm. Find the length of the arc intercepted by a central angle having each of the following measures.
- (i) $\frac{3\pi}{8}$ (ii) 144°

10.5 Summary

- **Circumference:** The length around the entire edge of a circle is called the circumference.
- The length of the circumference of a circle is equal to the radius of the circle multiplied by twice the value of π ($C = 2\pi r$).
- A **diameter:** A straight line going from one point on the circumference of a circle through the centre, to the opposite point on the circumference is called a diameter.
- A **radius:** A line segment joining the centre of a circle to a point on the circle is called a radius. The diameter of a circle is twice the length of a radius.
- An **arc:** Part of the circumference of a circle is called an arc.
- A **sector:** Part of a circle enclosed by two radii of a circle and their intercepted arc, a pie-shaped part of a circle.
- **Central angle:** A central angle is a positive angle whose vertex is at the centre of a circle.
- **Standard position of an angle:** We measure angles on a circle starting at the positive horizontal axis and moving anti-clockwise, unless instructed otherwise.
- We can conclude that the following are formulae that relate the circumference, diameter, and radius of a circle:
 - circumference = $\pi \times$ diameter
 - diameter = $2 \times$ radius
 - circumference = $2\pi r$
- Angles can be measured using different units such as revolutions and degrees. A **revolution** has a measure of 360° . An angle of 1° is (one three hundred and sixtieth) of a revolution. A degree can be subdivided further by using:
 - decimal notation
 - minutes and seconds

- **Concentric circles** are circles with different radii that share the same centre.
- We can think of 1 rad (**radian**) as the measure of a central angle that subtends an arc with a length equal to the circle's radius.
- The ratio of the arc length to the radius of the circle angle: $(\theta) = \frac{\text{arc length } (s)}{\text{radius } (r)}$ (s and r must be expressed in the same unit). Algebraically we write $\theta = \frac{s}{r}$ where θ is in radians.
- To convert from radians to degrees, we multiply radians by $\frac{180^\circ}{\pi}$
- To convert from degrees to radians, we multiply degrees by $\frac{\pi}{180^\circ}$

10.6 Consolidation exercises

- Use $\pi = 3,14$ in your calculations.
 - What is the circumference of a wheel with a diameter of 80 cm?
 - An athlete runs two and a half times around a field with a radius of 80 m. How far did the athlete run?
 - An architect designs a circular building with a circumference of 12 km. What will the diameter of this building be? (Give your answer in meter.)
- Convert the following to degree-minute-second form:

(a) $89,658^\circ$	(b) $126,25^\circ$	(c) $256,02^\circ$
(d) $50,123^\circ$	(e) $330,256^\circ$	(f) $111,11^\circ$
- Convert the following to decimal degrees:

(a) $25^\circ 22' 40''$	(b) $69^\circ 64' 89''$	(c) $150^\circ 55' 55''$
(d) $323^\circ 14' 69''$	(e) $5^\circ 30' 30''$	(f) $254^\circ 59' 23''$
- Find the measure of a central angle that intercepts an arc for each of the following:
 - What is the measure in radians of a central angle θ that intercepts an arc length of 21 cm on a circle with a radius of 7 cm?
 - What is the measure in radians of a central angle θ that intercepts an arc length of 42 cm on a circle with a radius of 7 cm?
 - What is the measure in radians of a central angle θ that intercepts an arc length of 14 cm on a circle with a radius of 7 cm?
 - What is the measure in radians of a central angle θ that intercepts an arc length of 12 cm on a circle with a radius of 4 cm?

- (e) What is the measure in radians of a central angle θ that intercepts an arc length of 28 cm on a circle with a radius of 4 cm?
- (f) What is the measure in radians of a central angle θ that intercepts an arc length of 8 cm on a circle with a radius of 7 cm?

5 Convert the following angles to degrees (do not use a calculator).

- (a) $\frac{5\pi}{2}$ (b) $\frac{12\pi}{9}$ (c) $\frac{\pi}{45}$
 (d) $\frac{3\pi}{14}$ (e) 5π (f) $\frac{25\pi}{18}$

6 Convert the following angles to radians (do not use a calculator).

- (a) 52° (b) 12° (c) 158°
 (d) 325° (e) 21° (f) 264°

7 Add the following and give the answer in degrees:

- (a) $\frac{3\pi}{2} + 2\pi - \frac{\pi}{3}$ (b) $\frac{5\pi}{2} + \frac{6\pi}{3} - \frac{\pi}{5}$ (c) $6\pi - 15^\circ + \frac{4\pi}{3}$
 (d) $\frac{12\pi}{15} + \frac{\pi}{8} - 60^\circ$ (e) $3\pi - \frac{\pi}{25}$ (f) $\frac{2\pi}{3} - \frac{2\pi}{5}$

8 Complete the following practical investigations:

- (a) Two gears are rotating. The smaller gear has a radius of 17 cm and the larger gear's radius is 25 cm. What is the angle through which the larger gear has rotated when the smaller gear has made one complete revolution?
- (b) A smaller gear and a larger gear are meshed. A 95° rotation of the small gear causes the larger gear to rotate through 65° . Find the radius of the larger gear if the smaller gear has a radius of 18,5 cm.
- (c) Calculate the angle in radians through which a pulley with a diameter of 2,3 m moves if a length of belt of 120 m passes over the pulley.
- (d) A road wheel, with a diameter of 8 500 mm, turns through an angle of 170° . Calculate the distance moved by a point on the tyre thread of the wheel.
- (e) Find the radius of the pulley if a rotation of $58,28^\circ$ raises the weight 23,4 cm.
- (f) A rope is being wound around a drum with radius 0,7 metres. How much rope will be wound around the drum if the drum is rotated through an angle of $44,72^\circ$?
- (g) A circle has a radius 35 cm. Find the length of the arc intercepted by a central angle having each of the following measures.
- (i) $\frac{3\pi}{8}$ (ii) 144°

11 FINANCE AND GROWTH

This chapter focuses on the spending and investing value of money.

In this chapter, you will learn:

- how to calculate simple interest
- how to calculate compound interest
- how to compare different investments
- about hire purchase
- about inflation and its effects
- about exchange rates and their effects

11.1 Investing through simple interest

Situation: Mimi’s friend, Modiba, an experienced builder, wants to start his own construction company. He has a bit of savings but needs extra money to buy equipment.

He asks Mimi to invest R12 500 in his business. He promises to pay her back when his business is up and running. After doing a few calculations, they draw up an agreement for how he will repay her. They agree that he will also pay her 1,75% interest of the investment amount for each month, until he repays her. When he repays her, he will owe her the R12 500 plus the total interest up to the end of the current month. Mimi trusts Modiba completely and knows he will repay her everything when he has the money.

From Mimi’s point of view, she is investing R12 500 in Modiba’s start-up business. She represents the situation for herself on a **timeline** – a number line for time:

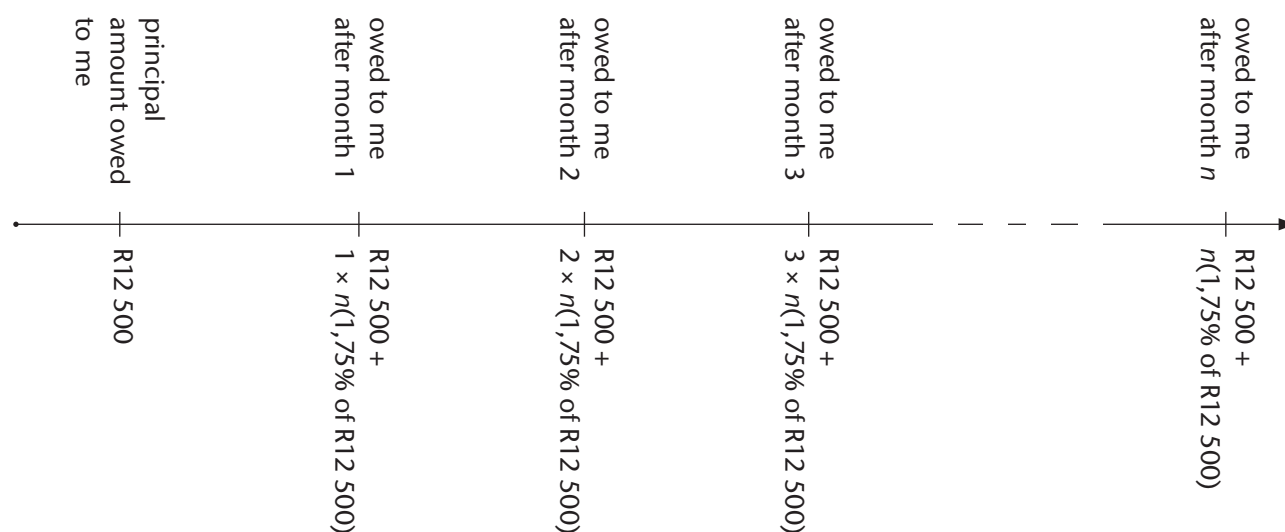

Final value of Mimi’s investment = R 12 500 + *total interest*

$$\begin{aligned}
 &= \text{R}12\,500 + \text{R}12\,500 \times \frac{1,75}{100} \times \textit{number of months} \\
 &= \text{R}12\,500 \times \left(1 + \frac{1,75}{100} \times \textit{number of months} \right)
 \end{aligned}$$

Let us use some symbols for the different quantities in our example:

- A final total value of the investment (called the **accumulated value**)
- P initial amount invested (called the **principal value**)
- i **interest rate** per time unit, here per month, expressed as a decimal fraction
- n **number of time units**, here number of months, over which interest is calculated

This leads us to a formula and proper definition of simple interest:

Simple interest is calculated only on the principal value:

$$A = P(1 + in)$$

The total interest is given by $A - P = Pin$

Where is simple interest used? Usually in situations where it is important to keep things easy to understand:

- Informally, for private loans between individuals; financial institutions such as banks usually use compound interest – see the next section.
- Grassroots community banking, where loans are made simple to understand.
- Government bonds, which are really just loans to the government by individuals; the government guarantees that it will pay interest on certain fixed dates.
- Hire purchase.
- In situations where interest is paid out during the time, and not at the end e.g. if Modiba paid Mimi the interest every month, instead of at the end.

Exercises

- 1 Mimi pays the R12 500 into Modiba's business account on 1 March 2015.

Mimi draws up the following table for Modiba, showing how much he owes each month for the first year:

If you pay back on	n , number of months you take to repay me	$A - P$, the total interest you owe me (to the nearest cent)	A , the total amount you owe me (to the nearest cent)
1 March 2015	0	R0	R12 500
1 April 2015	1		
1 May 2015	2		
1 June 2015	3		
1 July 2015	4	R875	R13 375
1 August 2015	5		
1 September 2015	6		
1 October 2015	7		
1 November 2015	8		
1 December 2015	9		
1 January 2016	10	R2 187,50	R14 687,50
1 February 2016	11		
1 March 2016	12		

Redraw the table in your exercise book and calculate the missing values. A few values have been given so that you can check that you understand the calculations.

- Describe in your own words how the amount Modiba owes Mimi changes from month to month. Write down an expression that gives the change, using the symbols P and i .
- What is the total, i.e. effective, interest rate Modiba pays after three months? After six months? After one year? Give your answers as percentages.

Hint: Calculate the percent increase of the accumulated value compared to the principal for each of these three times.

- You will need some graph paper for this question. Use your completed table to plot the total amount Modiba owes each month, as a graph. The horizontal axis is a time line marked in months. The vertical axis is in Rand. What kind of graph do you get? Should you 'connect the dots' or just leave them as points?
- Look carefully at the formula for simple interest. Rewrite the formula in the standard form for a straight line function. Clearly indicate where the gradient and where the *A-intercept* are.
- The first row for March may seem a little strange because Mimi expects the total interest for each month. Does it make mathematical sense though? How?

- Redraw the following table and complete the number pattern. The pattern gives the multiplication factor for each month that Modiba owes Mimi:

Number of months until Modiba pays Mimi	1	2	3	4	5	...	n
Multiplication factor in algebraic form	$1 + \frac{1,75}{100}$			$1 + 4 \times \frac{1,75}{100}$...	
Multiplication factor in decimal form	1,017 5		1,052 5			...	

- Go back to exercise 1 (c). Do you notice anything new from before? If you do, describe what you notice.

If you understand how the multiplication factor works, the formula for simple interest no longer has any secrets to keep from you!

Worked example

Problem: A sum of money is invested at 12% p.a. simple interest. After seven years, the value of the investment is R23 920. What amount was invested?

Solution:

$$\begin{aligned}A &= P(1 + in) & A &= 23\,920 \\23\,920 &= P(1 + 0,12 \times 7) & i &= \frac{12}{100} = 0,12 \\ \text{so } P &= \frac{23\,920}{(1 + 0,12 \times 7)} & P &=? \\ &= R13\,000 & n &= 7\end{aligned}$$

Worked example

Problem: R6 000 is invested using simple interest calculated every month for 30 months. The total interest is R1 125. What is the monthly interest rate as a percent?

Solution 1: Using the formula directly

$$\begin{aligned}A &= P(1 + in) & A &= 6\,000 + 1\,125 = 7\,125 \\7\,125 &= 6\,000(1 + i \times 30) & P &= 6\,000 \\ \text{so } 1 + 30i &= \frac{7\,125}{6\,000} & i &=? \\ 30i &= \frac{7\,125}{6\,000} - 1 & n &= 30 \\ i &= \frac{\frac{7\,125}{6\,000} - 1}{30} \\ &= 6,25 \times 10^{-3}\end{aligned}$$

Therefore, % interest = $100 \times i = 0,625\%$ per month

Solution 2: Working smart and using the interest part of the formula.

$$\begin{aligned}1\,125 &= 6\,000 \times i \times 30 & A - P &= 1\,125 \\ \text{so } i &= \frac{1\,125}{6\,000 \times 30} & P &= 6\,000 \\ & & i &=? \\ & & n &= 30\end{aligned}$$

Therefore, % interest = $0,625\%$ per month

Exercises

- 3 Fahrieda is buying her first car. It carries a price tag of R75 000. She has just started working after completing her studies and cannot afford it. Her parents offer to buy the car for her. Fahrieda believes she will have savings after working for five years and promises to pay her parents back in five years' time. She decides that she will add simple interest at 6% p.a. to make up for inflation (see section 11.5). How much will she owe her parents?
- 4 Olebogeng invested R5 000 at simple interest calculated per month. After 42 months, he withdraws the total value of his investment, R7 625. What was the monthly interest rate over the term of the investment?
- 5 Unathi tells her friends that she has invested some money in a friend's business for four years. She says that the annual simple interest she received was R5 100, and that the interest rate was 17% p.a.
- (a) What was the amount she originally invested?
(b) What was the total value of her investment after three years?
- 6 After a certain number of years, Gideon's investment of R2 500 has grown through simple interest, calculated monthly, to R2 972, rounded to the nearest Rand. The annual interest rate is 7,81%. For how long did he invest his money? Give your answer in years and months.
- 7 Cornelia buys a government bond valued at R5 000. Simple interest at 3,25% is calculated every six months. The bond matures (is paid out) after 30 months.
- (a) How much interest will Cornelia earn every six months?
(b) What is the total interest she will receive?
- 8 Compare the effects of different simple interest rates, you will need graph paper for this. Draw up a table of n and A values for $P = R1\ 000$ for the situations (a) to (c) using $n = 1$ to 5:
- (a) $i = 0,10$ (b) $i = 0,20$ (c) $i = 0,30$
- Plot the sets of points for the three situations on graph paper. What do you notice? Explain by using your understanding of straight line graphs and linear functions.
- 9 Compare the effects of different principals, you will need graph paper for this. Draw up a table of n and A values for $i = 0,20$ for each of the situations (a) to (c) using $n = 1, 2, 3, \dots, 5$:
- (a) $P = R500$ (b) $P = R1\ 000$ (c) $P = R1\ 500$
- Plot the sets of points for the three situations on graph paper. What do you notice? Explain using your understanding of straight line graphs and linear functions.

11.2 Investing through compound interest

Situation revisited: Modiba and Mimi could have come to a different agreement about the interest. Instead, at the end of each month, the latest interest is calculated on the *total amount* Modiba owes up to the *previous month*, not only on the R12 500 he borrowed. What does this mean? To get the total amount owed by Modiba at the end of any month, Mimi must calculate the next month's interest using both the principal and the total interest up to the end of the previous month:

$$\text{total amount at end of a month} = \text{total amount owed end of previous month} \times (1 + i)$$

Why do we do this? Well, since Modiba is only paying the loan and the interest back at the end, Mimi can argue that he should also pay interest on the interest he owes. From Mimi's point of view, each bit of interest Modiba doesn't pay to her immediately is an extra investment by Mimi in Modiba's new company.

Exercise

- 10 (a) What is the decimal value multiplying factor, $(1 + i)$, Mimi must use every month?
- (b) Redraw the following table in your exercise book and complete it. It is similar to the table for simple interest in exercise 1 (a), except you must calculate the values according to the approach above. Note that column 2 and 3 are swapped. Why?

If you pay me back on	n – number of months you take to repay me	A – the total amount you owe me (to the nearest cent)	$A - P$ – the total interest you owe me (to the nearest cent)
1 March 2015	0	R12 500	R0
1 April 2015	1		
1 May 2015	2		
1 June 2015	3		
1 July 2015	4	R13 398,24	R898,23
1 August 2015	5		
1 September 2015	6		
1 October 2015	7		
1 November 2015	8		
1 December 2015	9		
1 January 2016	10	R14 868,06	R2 368,06
1 February 2016	11		
1 March 2016	12		

(c) Copy and complete the following timeline:

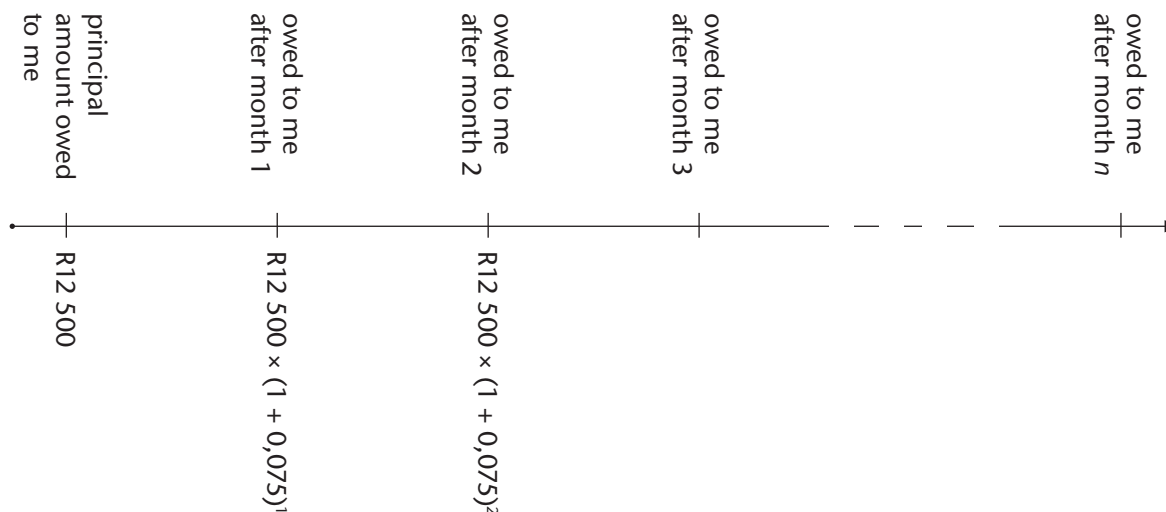

- (d) Describe in your own words how the amount Modiba owes Mimi changes from month to month. Write down an expression that gives the change, using the symbols P and i .
- (e) What effective percent interest does Modiba pay after three months? After six months? After one year?

Hint: Calculate the percent increase of the accumulated value compared to the principal for each of these three times.

- (f) You will need some graph paper for this question. Use your completed table to plot the total amount Modiba owes each month, as a graph. The horizontal axis is a time line marked in months. The vertical axis is in Rand. Should you 'connect the dots' or just leave them as points?
- (g) Look carefully at the formula for simple interest. Compound interest is described as a form of exponential change. Do you agree?
- (h) The first row, for March, may seem a little strange because Mimi expects the total interest for each month. Does it make mathematical sense though? How?

The word 'compound' means 'put together'. This is called **compound interest** because the interest is compounded with the principal value at any time to calculate the next accumulated value.

Compound interest

Interest is not only charged on the principal, but also on the total interest gained up to the end of the previous time unit. Using the same symbols as before, we get the compound interest formula:

$$A = P(1 + i)^n$$

The interest part of the total amount owed back will be:

$$\begin{aligned} A - P &= P(1 + i)^n - P \\ &= P[(1 + i)^n - 1] \end{aligned}$$

Our ‘problems are compounded’ when each problem creates yet more problems. You may be unfortunate to have experienced the compounding misfortune of falling behind in your schoolwork. We’ve all been there!

Where do we use compound interest? Whenever a financial institution deals with loans or investments, such as:

- Home and vehicle loans: the financial institution ‘invests’ in what you buy by paying for it. You then pay that back along with interest.
- If you invest your money indirectly through investment funds, or directly by buying into a business.

Worked example

Problem: A sum of money is invested at 12% p.a. compound interest. After seven years, the value of the investment is R28 738,86. What amount was invested?

Solution:

$$A = P(1 + i)^n$$

$$A = 28\,738,86$$

$$28\,738,86 = P(1 + 0,12)^7$$

$$i = \frac{12}{100} = 0,12$$

$$\text{so, } P = \frac{28\,738,86}{1,12^7}$$

$$n = 7$$

$$= R13\,000$$

$$P = ?$$

Worked example

Problem: R6 000 is invested using compound interest calculated every month, for 30 months. The total interest is R1 125. What is the monthly interest rate as a percent?

Solution:

Note: Your calculator has a button for this, $\sqrt[30]{\frac{7\,125}{6\,000}}$; read the manual for your calculator, or ask your teacher to help you find this button.

$$\begin{aligned}A &= P(1 + i)^n & A &= 6\,000 + 1\,125 \\7125 &= 6\,000(1 + i)^{30} & &= 7\,125 \\ \text{so } (1 + i)^{30} &= \frac{7\,125}{6\,000} & P &= 6\,000 \\ 1 + i &= \sqrt[30]{\frac{7\,125}{6\,000}} \\ i &= \sqrt[30]{\frac{7\,125}{6\,000}} - 1 & n &= 30 \\ &= 5,74 \times 10^{-3} & i &=?\end{aligned}$$

Therefore, % interest = $100 \times i = 0,574\%$ per month.

Worked example

Problem: A loan to the value of R15 000 is made, with compound interest charged annually at a rate of 20%. The loan and total interest value are repaid in one instalment and this amounts to R31 104. For how many years was the loan held?

Solution:

$$\begin{aligned}A &= P(1 + i)^n & A &= 31\,104 \\ 31\,104 &= 15\,000(1 + 0,20)^n & P &= 15\,000 \\ \text{so } 1,2^n &= \frac{31\,104}{15\,000} & i &= \frac{20}{100} = 0,20 \\ 1,2^n &= 2,0736 & n &=?\end{aligned}$$

We have a problem here. Recall from the chapter on exponents that we do not have a mathematical tool to solve this directly. Whenever we cannot solve an equation directly, there is always a back door! We do a numerical search.

We know that n must be a whole number as we are counting years. So, let's test whole numbers starting with 2 (clearly $n \neq 1$):

Test $n = 2$	$(1,2)^2 = 1,44$	too low
Test $n = 3$	$(1,2)^3 = 1,728$	too low
Test $n = 4$	$(1,2)^4 = 2,0736$	got it!

11.3 Hire purchase

Sometimes you need to buy something for which you do not have enough money. There are three ways of doing this, namely:

- taking out a loan
- buying with a credit card
- buying on hire purchase

Generally, a loan is a bad idea, unless you have no other way and you absolutely have to take one, because the interest on loans, especially personal loans, is very high. Financial institutions offer loans that are difficult to pay off because it has high interest rates, sometimes as high as 20% or more.

Examples of situations where loans may be unavoidable are, when buying a house or a flat, or when buying a car or a motorcycle. Often students need to take out student loans to complete their studies, a completely unavoidable situation. Luckily, student loans have special terms and the interest is only charged once the course has ended. They usually state this in the loan agreement – the loan must be paid back whether the course is completed in time or not!

Buying with a credit card regularly is only a good idea if you know you can pay the card off with your next salary. Otherwise, the interest is too high, in the region of 18% per year. Sometimes, banks will only start charging interest on credit after a month or two. To be safe, you should never get into more debt with your card than you can repay within the next two months from your salary. More debt than that may become very difficult to pay off. Debt has a way of **compounding** once you lose control over it!

Usually, the best option for something relatively inexpensive, e.g. a TV, sound system, washing machine etc., is hire purchase – although, sometimes more expensive items such as houses and cars are also sold in this way. **Hire purchase** is a legal agreement between a buyer and a seller where something is bought by paying it off in regular, usually monthly, instalments. The buyer has full use/access to the item while paying it off.

The American term for this arrangement is clearer: ‘rent to own’. You are renting the item until you own it. Legally, the seller owns the item until the full amount has been paid. However, the buyer has full use of the item while it is being paid off. If the buyer stops paying the regular instalments, called defaulting, then the seller may repossess the item and keep any money paid up to that point.

Sometimes a deposit must be paid at the start. Usually interest is also charged. When interest is charged, it is usually simple interest to make things easier for the consumer. We will always assume that simple interest is used. Often the seller will also include an insurance fee against damage to the item.

Worked example A real situation you may face in the future

Problem: A fridge costs R4 990. The seller requires a deposit of 15%. The balance is paid off in 48 monthly instalments. Simple interest is charged at 21,65% p.a. Insurance at 2,5% is charged for each instalment.

- A. What is the monthly instalment, excluding insurance?
- B. What is the total monthly instalment, including insurance?
- C. How much more will the fridge cost than if it were bought cash?

Solution to A:

$$\text{deposit} = 0,15 \times R4\,900 = R748,50$$

$$\text{balance} = 0,85 \times R4\,990 = R4\,241,50$$

$$\begin{aligned}\text{accumulated value} &= P(1 + ni) \\ &= 4\,241,50 \times (1 + 4 \times 0,2165) && \text{[48 months = 4 years]} \\ &= R7\,914,64\end{aligned}$$

$$\begin{aligned}\text{monthly instalment} &= A \div 48 \\ &= 7\,914,64 \div 48 \\ &= R164,89\end{aligned}$$

Solution to B:

$$\begin{aligned}\text{instalment with insurance} &= 164,89 \times 1,025 && \text{[increase the instalment by 2,5\%]} \\ &= 169,01 \\ &\approx R169\end{aligned}$$

Usually the seller will round off the instalment to the nearest Rand.

Solution to C:

$$\begin{aligned}\text{total H.P. cost} &= \text{deposit} + \text{sum of all instalments} \\ &= R748,50 + 48 \times R169 \\ &= R8\,860,50\end{aligned}$$

So, the fridge will cost $R8\,860,50 - R4\,990 = R3\,870,50$ more on H.P. than its cash price.

Does the result of this calculation shock you? If you don't believe this, have a look at a shop brochure that offers H.P./credit terms. The interest rate is taken from a well-known chain of shops. Can you see that H.P. is only a good idea if you really need something? Financially, it is very unwise to pay almost double for something you don't urgently need. Rather save and pay cash for it later. Building wealth starts with being smart with your money.

Exercises

- 18 Siphon urgently needs to buy a motorbike to get to work. He sees a great deal at a motorcycle dealership in town, a bike advertised at R55 000. However, he has only saved R21 000. The floor manager makes a deal with him: She offers Siphon a hire purchase deal where he pays the R21 000 as a cash deposit and then pays monthly instalments of R1 285 for the next three years.
- What is the total amount of interest Siphon pays?
 - What is the annual percentage interest he is paying?
 - Do you think the floor manager gave him a good deal?
- 19 The electronic notepad Ana wants to buy has a floor price/cash price of R9 990. The retailer offers a hire purchase option of payment over 30 months, with an interest rate of 1,45% per month, no deposit required. There is a once-off administration fee of R150 and an insurance fee of R25 per month.
- Calculate the total interest on the floor price under the hire purchase agreement.
 - Calculate the monthly instalments due.
 - Calculate the percentage increase in the total cost of the notepad under the agreement.
- 20 Frik needs to furnish his new flat. He decides to buy a dining room table and six chairs. The normal retail price of the set he would like to buy is R10 990. He negotiates with the dealer to pay a 25% deposit from his savings and to pay off the balance monthly, over two years. The store interest rate on H.P. is 18,75% p.a. What will he pay per month, rounded off to the nearest R10?
- 21 Albert and Gretchen currently rent a two-bedroomed flat for R6 500 p.m. and need to buy a place to stay. Gretchen's Aunt Kitty has a flat valued at R560 000. Aunt Kitty is moving into a retirement home so she makes the following offer to Gretchen: They can pay her R7 500 per month as rent. If they do so for ten years, the flat becomes theirs. They can choose to move out and stop paying at any time before that. But, if they do this, the flat remains Aunt Kitty's.
- After how many months will Albert and Gretchen pay back the value of the flat?
 - What is the total interest they pay after ten years?
 - What is the annual interest rate that Aunt Kitty is offering over the ten-year period?
 - Do you think this is a good deal for Aunt Kitty? Discuss.
 - Do you think this is a good deal for Gretchen and Albert? Discuss.
- 22 Gladys needs to buy a fridge. She has enough cash for an R800 deposit. She can afford to pay R150 per month towards the fridge. The appliance shop she plans to buy her fridge at, stocks a range of models at different prices. She has to decide which fridge she can afford under a hire purchase agreement. The shop has the following conditions for H.P: annual interest at 20,5%; term at 48 months. Calculate the floor price of the most expensive fridge she can afford.

11.4 Inflation

In economics, the word inflation is used to describe the increase in the cost of goods over time. **Inflation rate** is the percentage increase in the price of an item or service. The mathematics of inflation is the mathematics of compound interest:

$$\text{inflated value} = \text{base value} \times \left(1 + \frac{\text{inflation rate}}{100}\right)^{\text{number of years}}$$

You probably know that a 2,5kg bag of mealie meal or a loaf of bread costs more now than it did when you were in Grade 1. The amount and quality of the mealie meal has not changed. We say that its **intrinsic value** is unchanged. It just costs more. This is inflation at work. The word ‘inflate’ means ‘to expand’ or ‘get bigger’.

Note that sometimes an item seems to stay at the same price over a period of a few years. In such a case, it is possible that either the quality of the item or the amount of it has decreased. You may be paying the same price but what you are getting is not the same. Some economists have made up a new word to describe this: ‘*stealthflation*’. The word ‘stealth’ means to sneak about doing something quietly, e.g. you may be paying the same price for a tube of toothpaste but find that the toothpaste tube is getting smaller and smaller every year. Consumers have to be on the lookout for stealthy changes like these.

Official inflation rates are calculated every month. Average inflation rates are also calculated per year, per decade, etc. There is a specific formula that Statistics SA will use to calculate the rate. It is based on something called the **Consumer Price Index** (CPI), which you can look up and find out more about by yourself. Below is a graph that shows the South African inflation rate from 1957 to 2013.

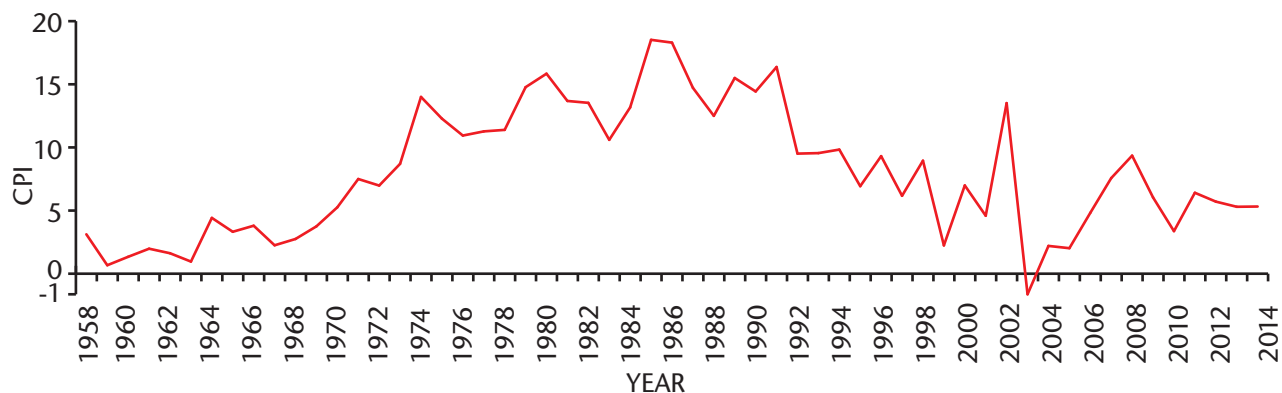

As the graph shows, inflation is never constant. It changes from month to month and year to year. We can calculate the effective/average inflation rate over any time using the compound interest equation by making i the subject of the formula:

$$i = \sqrt[n]{\frac{\text{inflated price after } n \text{ years}}{\text{base price at beginning of } n \text{ years}}} - 1$$

The causes of inflation are quite complex. The main cause is that the total amount of money in the economy gradually increases over time. Governments carefully control the total amount of money to try to keep the economy as healthy as possible. Too little money to go around and people not spending means the economy slows down. Too much money and businesses lose confidence in the economy and it cannot catch up. The trick is to get inflation just right so that it encourages the economy to grow as fast as possible without making it impossible for the economy to catch up.

When inflation drops below 0% we have what is called **deflation**. This is usually not a good thing as it indicates that productivity is slowing down. The inflation rate of the United Kingdom fell to -0,1% in April 2015. This had British economists worried.

When inflation is very, very high, as happened in Zimbabwe recently and in Germany in the 1920's, we have what is called **hyperinflation** or runaway inflation. The highest official inflation rate in Zimbabwe was 231 150 888,87% during July 2008. After that it went even higher, but only estimates are available. Hyperinflation is a very bad situation because cash cannot keep its value long enough to be useful, e.g. a loaf of bread may cost 125 times more at the end of a week than it did at the beginning of the week. Usually, hyperinflation happens when the economy slows down too much. The central bank begins printing more and more money to try to get it going again. If the economy cannot respond, the inflation rate snowballs out of control.

Worked example

Showing inflation is exponential and not linear

Problem: A loaf of bread costs R10. One year later it costs R10,60.

- What is the inflation rate for a loaf of bread?
- What will the loaf of bread cost after another year, assuming the same inflation rate?
- What will the loaf of bread cost after n years, assuming the same inflation rate?

Solution A:

$$\begin{aligned} \text{inflation rate} &= \frac{\text{change in cost}}{\text{initial cost}} \times 100 \\ &= \left(\frac{10,60 - 10,00}{10,00} \right) \times 100 \\ &= 6\% \end{aligned}$$

Solution B:

$$\begin{aligned} \text{cost two years later} &= \text{cost one year later} \times (1 + 0,06) \\ &= [\text{original cost} \times (1 + 0,06)] \times (1 + 0,06) \\ &= 10,00 \times (1 + 0,06)^2 \\ &= R11,24 \end{aligned}$$

Solution C:

For each year we multiply by 1,06, so after n years we multiply by $1,06^n$. So:

$$\text{cost after } n \text{ years} = \text{original cost} \times (1 + i)^n \text{ or } A = P(1 + i)^n$$

Note: We are assuming no 'stealthflation' here and that the intrinsic quality of the loaf of bread is the same throughout.

Worked example

Calculating the base value

Problem: The average inflation rate for house prices in a particular suburb over the last five years has been 5%. If the average sales price of a three-bedroomed house is R960 000 at present, what was it five years ago, rounded to the nearest ten thousand Rand?

Solution:

$$A = P(1 + i)^n$$

$$A = 960\,000$$

$$960\,000 = P(1 + 0,05)^5$$

$$P = ?$$

$$\text{so } P = \frac{960\,000}{1,05^5}$$

$$i = \frac{5}{100} = 0,05$$

$$= 752\,185,12$$

$$n = 5$$

$$\approx R750\,000$$

Note that house prices change depending on the demand for houses in a neighbourhood. If few people wish to live in a neighbourhood, house prices are usually lower than in neighbourhoods that are very popular. This makes house price inflation behave a little differently to inflation of foods and household items.

Exercises

- 23 A 400 g jar of peanut butter costs R18,90 at present. Economists project an inflation rate of 5,5% for the next three years. What do we expect the same jar of peanut butter to cost then, rounded off to the nearest ten cents.
- 24 In 2006, a kilogram of a popular brand of instant coffee cost R32,99. What did the same coffee cost in 1994 if the effective inflation rate for this brand of coffee was 4,85% during this period?
- 25 Refer to Exercise 3. Fahrieda's parents did not want to charge her interest. She decided that she should at least make up for the effects of inflation. When she repays her parents, the cost of the same model car is R105 000.
- (a) What is the annual inflation rate for the model of car she has bought?
- (b) Has she made up for the effects of inflation?

- 26 Refer to exercise 21. After the ten years have passed, Gretchen and Albert take ownership of the flat. They have the following inflation data for the value of flats in their complex for each of the ten years:

year	1	2	3	4	5	6	7	8	9	10
rate	2%	7%	0,5%	4%	4,3%	3,8%	8%	9,5%	11%	6,2%

- (a) Calculate the value of the flat at the end of the ten-year period, based on these inflation values.
- (b) From the point of view of the effects of inflation, have they made a good investment buying the property in this way?
- 27 In 2010, a 2,5 kg packet of sugar cost R12. The same packet cost R15 in 2015. Calculate the effective inflation rate for sugar, based on these values.
- 28 Stealthflation in action: A confectionary company produced 200 g slabs of milk chocolate in 2008. The slabs were reduced to 180 g in 2010, and then to 150 g in 2014. The retail prices of the slabs in four years are given below:

Month and year	Mass of slab (g)	Retail price of slab
January 2008	200	R 15,95
January 2010	180	R 17,95
January 2013	180	R 21,50
January 2015	150	R 21,50

- (a) Copy and complete the following table:

Month and year	Cost per 100 g
January 2008	
January 2010	
January 2013	
January 2015	

- (b) Calculate the annual inflation rate for the period January 2008 to January 2010.
- (c) Calculate the annual inflation rate for the period January 2010 to January 2013.
- (d) Did the price of a slab of milk chocolate inflate over the period January 2013 to January 2015? Explain.
- (e) Is the inflation rate the same from year to year? Explain what the results of your calculations in (b) and (c) mean.

11.5 Exchange rates

If you wish to buy something online from a foreign country, you have to pay for it in the currency of that country. If you travel to a foreign country, you have to pay for everything in their currency.

If you are buying from a US seller then you have to pay in American Dollars. To do this, you have to convert your Rand into Dollars. How many Dollars for each of your Rand?

Exchange rate is the ratio of one currency to another. It is constantly changing, not just from day to day, but during the day as well.

Note: When you go to a bank to exchange one currency to another you have to pay an exchange fee to the bank for the service. This means that you will get less of the new currency than you expect from the exchange rate.

Worked example Rand to Dollars

Problem: You order a boxed set of CDs online, costing \$28. The Rand/Dollar exchange rate is R12 to the Dollar. What will the cost be in Rand?

Solution: Let the price in Rand be x , using ratios:

$$\frac{\text{price in Rand}}{\text{price in Dollars}} = \frac{x}{\$28} = \frac{\text{R12}}{\$1}$$
$$\text{therefore } x = \frac{\text{R12}}{\$1} \times \$28$$
$$= \text{R336}$$

Normally, when you exchange one currency for another, you pay an extra amount to the financial institution handling the exchange. So, in the case above, you will pay an extra fee. Also, you will have to pay VAT at 14% on the CDs once they arrive in South Africa and if you don't pay, they send it back. Your online purchase may end up costing more than R400 in the end.

The exchange rate was at around R6,70 to the Rand in April 2011 and at a thirteen-year high of R12,05 to the Dollar in March 2015. Exchange rates have to do with the strength of the economy; in other words, if the economy is healthy and if economic activity is happening, and so foreign investors have trust in the economy.

Terminology: high/low exchange rates and **weak/strong** currency

- R6,70 to the dollar is a *low exchange* rate compared to R12,05
- R6,70 to the dollar means the *Rand is stronger* than when it is R12,05 to the dollar

Generally, a currency will become stronger when there is more investment, and weaker when there is less. Without investment in the country's industries, the country can't produce enough. It then imports too much and exports too little, causing the currency to weaken, making it even more difficult to import what it cannot produce, causing inflation.

		BUY	SELL
	USD	12.70 13	13.380 1
	GBP	19.6948	20.7476
	EUR	14.4396	15.1963
	CHF	0.0943	0.0947
	SEK	0.7886	0.6354
	DKK	0.6072	0.6567
	NOK	0.7184	0.5079
	AUD	0.1241	0.1005
	CAD	0.1226	0.0965
	JPY	10.5602	9.5204
	HKD	0.7088	0.5930
	NZD	0.1441	0.1114

Further Rates Available. Above Rates an Indication Only

Exercises

- 29 You are planning a 10 day trip to Los Angeles. You need to have spending money for each day you are there. You have saved R14 000 for this. Your friend in Los Angeles tells you that you will need about \$120 per day to get by. The exchange rate is R11,54 when you book your flight.
- Is R14 000 enough to cover your daily expenses according to the given exchange rate?
 - A few weeks later, just a few days before you leave on your trip, you notice that the exchange rate has increased to R12,10. How much extra money, in Rand, do you need to cover your expenses now?
 - Could you have planned for this or was it just bad luck? Explain.
- 30 An engineering firm is involved in a big project building a power station. The budget has been carefully calculated. A particular unit that has to be installed in the power station is made in France and costs €870 000. At the time the budget is drawn up, the exchange rate is R1 = €0,090. The payment for the unit is to be made one year later, just before the unit is to be delivered and installed.
- How much money, in Rand, must be budgeted for the unit, based on the given exchange rate?
 - The project is delayed by six months. By the time the unit is to be ordered, the Rand has weakened to €0,080. How much over-budget is the project because of the delay in installing the unit?

- 31 Dimakatso likes to invest her spare cash in rare comic books. In 2010, she bought a book at an online auction in Tokyo for JPY 12 000 (Japanese Yen). In 2014, she sells the same comic book to an American collector for USD 250 (US Dollars). The exchange rates between ZAR (South African Rand), USD, and JPY at the two dates are given in the table:

September 2010	ZAR 1	USD 0,140	JPY 11,8
December 2014	ZAR 1	USD 0,086 9	JPY 10,3

- Did the ZAR weaken or strengthen compared to the USD and to the JPY? Explain.
- Did the JPY weaken or strengthen compared to the USD? Explain.
- What did she sell the book for in JPY?
- What percentage profit did she make on the comic book in USD?
- What percentage profit did she make in ZAR?
- Is she a good business person or is she just very lucky? Discuss.
- Has anything been left out of these calculations, for instance, additional costs that may make her 'profit' in Rand smaller?

11.6 Summary

- **Simple interest:** calculated on the principal only; the amount of interest is the same for each time period.
 - Simple interest formula: $A = P(1 + ni)$
 - A is a linear function of n
 - Pi is the gradient and P is the A -intercept
 - Interest part: $A - P = Pni$
- **Compound interest:** calculated on the accumulated value; the amount of interest gets bigger from time period to time period.
 - Compound interest formula: $A = P(1 + i)^n$
 - A is an exponential function of n
 - P is the coefficient and $1 + i$, is the base
 - Interest Part: $A - P = P[(1 + i)^n - 1]$
- **Hire purchase** ('rent to own'): a deposit may be paid; the balance is paid off in equal instalments with simple interest added; there may be additional fees e.g. insurance against damage or an admin fee.
- **Inflation:** the gradual increase in the cost of something with the same intrinsic value; related to factors such as productivity, level of investment, investor confidence, total supply of cash in circulation, strength of the currency i.e. exchange rate; a small inflation rate is considered ideal to keep the economy growing; too low or too high indicates problems with the economy and how it is managed; hyperinflation results from economic breakdown.

- **Exchange rate:** the ratio used to convert one currency into another; currency weakens when the rate increases and strengthens when the rate decreases; therefore, it is an important indicator of economic strength; it is important when dealing with international trade, tourism, etc.

11.7 Consolidation exercises

- 1 Andrew invests R5 000 at 15% simple interest p.a. and Glenton invests the same at 10% interest compounded annually. Whose investment is the greater after:

- (a) 4 years
- (b) 8 years
- (c) 12 years

Which investment is best?

- 2 Mpho and Cassandra each invest R5 000 at 12% p.a. Mpho's interest is simple while Cassandra's is compounded. Which investment is better?

- 3 A company in South Africa exports steel tables to a number of foreign countries, including Botswana and Venezuela. The selling price for a table in South Africa is R625,00. The exchange rates for the three currencies are given in terms of US Dollars:

100 South African Rand (ZAR)	8,47 US Dollar (USD)
100 Botswana Pula (BWP)	10,3 US Dollar
100 Venezuelan Bolivar (VEF)	15,7 US Dollar

- (a) How much will a buyer in Venezuela pay for a table in Bolivar?
 - (b) Complete: 1 USD = ? ZAR = ? BWP = ? VEF?
 - (c) A furniture shop in Gaborone has BWP 6 000 to spend on steel tables. How many can they buy?
 - (d) We have ignored the cost of shipping the tables to these countries. Which country is more affected by this when importing goods from South Africa; Botswana or Venezuela?
- 4 Refer to exercise 14. Sipiwe wants to take the effect of inflation into account. He decides to use his monthly living expenses, which are R2 500, to do this. He assumes that inflation will be a constant 5% for the forty years he invests.
 - (a) How many months' expenses can he pay for using the R10 000 gift at his current age of 20 years?
 - (b) Use the inflation rate to calculate his expected monthly expenses in 40 years' time when he turns 60.

- (c) How many months' expenses will be covered by his accumulated investment in 50 years' time?
- (d) He comes to the following conclusion: 'The investment interest rate of 17% increases the amount of money but the inflation rate decreases the value of the money'. Do you agree with his conclusion? Do you think it is important to take inflation into account when planning for long-term investments?
- (e) How reliable is his assumption about the inflation rate value? Explain briefly.

- 5 Giorgio wants to buy a gas stove. He has a particular model in mind. He can either buy the stove at retailer A or retailer B. He cannot pay cash for it, so he must buy it on H.P. The table below gives the H.P. deal for both retailers:

Retailer	Cost Price	Deposit	Simple Interest Rate	Period	Additional monthly costs
A	R13 500	10%	20%	48 months	R23
B	R14 350	15%	21%	48 months	none

Based on the given information, which H.P. agreement is the better deal for Giorgio?

- 6 Lerato invests R7 000, simple interest, at 13,5% per annum, for 5 years. How much money will she have at the end of the investment period?
- 7 James wants to receive R54 800 after a 10-year investment period. How much must he invest if he receives an interest rate of 18% compounded annually?
- 8 Peter receives R11 600 after investing R5 000 for 10 years. What percentage compound interest did he earn?
- 9 Thandi buys a house for R2 300 000. She needs to pay a transfer fee, which is 5% of the buying price. She also needs to pay a 15% deposit on this amount. What will her monthly instalment be if the bank charges her 8% simple interest p.a. over a period of 25 years?
- 10 Shane borrows R25 000, at 11% simple interest, in order to buy a new lounge suite. He pays the money back in 4 years, in monthly instalments.
- (a) What is the total amount that Shane will pay back?
- (b) What is the interest that he paid on top of the R25 000?
- (c) How much is his monthly instalments?
- (d) How much money would he save if he pays the amount back in 2 years, instead of 4 years?

-
- 11 Lindiwe receives a test score of $\frac{12}{80}$ for her math test. If she improves her marks by 50% each week, how long will it take her to pass her math test? In her school, the pass mark is agreed by learners and educators to be 50%.
- 12 Brian receives a monthly salary of R8 000. If his salary increases by 6% each year, what will he earn in 7 years' time?
- 13 A 700 g loaf of white bread cost R5,89 at the beginning of 2008. The same loaf cost R11,42 at the beginning of 2015.
- Calculate the annual inflation in the price of a 700 g loaf over the period.
 - Use your inflation rate to estimate the cost of a 700 g loaf at the start of 2014.
 - The actual cost of a 700 g loaf of white bread in January 2014 was R10,49. Compare this with your estimate and explain why the values are different.
- 14 A piano costs USD12 000.
- If the Rand/Dollar exchange rate is 8,3, what will you pay for it in SA currency?
 - You also need to pay 14% VAT on the buying price to have it imported to South Africa. How much VAT will you pay?
 - Importing levies are 17% of the buying price. How much will you pay on levies?
 - What is the total amount you paid for the piano?
- 15 In October 2014, the average cost of 2 litres of full cream milk was R23,28. The inflation rate for full cream milk between October 2013 and October 2014 was 16,47%.
- Calculate the cost of 2 litres of full cream milk in October 2013.
 - Supposing that the inflation rate for full cream milk remained the same over the next two years, estimate the projected cost of 2 litres of full cream milk in October 2015.
 - Give a reason why the actual average price will not be the same as the value you calculated in (b).
- 16 David saves R50 000 spending money for his overseas holiday. He changes all his money to British Pounds (GBP) at 1R/£17,20. He has to pay an exchange fee of 5% when he converts between currencies.
- How many GBP does he get?
 - After his holiday, he still has £564 left and converts it back to ZAR at 0,056 GBP to every Rand. How much Rand does he receive?
- 17 In 2012, the estimated world population was 8 billion.
- What will the world population be at a compound growth of 2,11% in 2015?
 - The growth rate changes to 1,25% after 2015. What will the population be in 2020?

GLOSSARY

Adjacent leg A leg next to an acute angle in a right-angled triangle; it forms one of the arms of the angle

Accuracy Describes how close the value is to the correct value (compare with **Precision**)

Accumulated value The total value of the investment (A) at a particular time

Acute-angled triangle All three interior angles are smaller than 90°

Additive inverse Of a number a is the number that, when added to a , equals to zero

Algebraic identity An algebraic statement that is true for all values of the input variables

Algebraic impossibility An algebraic statement where no values of the variable can make the statement a true mathematical statement

Alternate angles These are the two pairs of angles on opposite sides of a transversal through two lines, between the two lines; if the two lines are parallel then each pair of alternate angles are equal

Amplitude of a sine or cosine graph This is the maximum distance from the centre line to the graph. For sine and cosine this is 1. Amplitude is a positive quantity.

Angles Measure differences in direction or orientation, and amount of rotation; measured in degrees (full rotation = 360°), in radians (full rotation = 2π radians), or sometimes gradians

Arc Part of the circumference of a circle

Arc Length the length of an arc; a fraction of the **Circumference** of the circle

Associative Property grouping two or more **Operations** in different ways has no effect on the final value e.g. $(3 + 4) + 5 = 7 + 5$ is the same as $3 + (4 + 5) = 3 + 9$

Asymptote This is a line that the graph of a function gets closer and closer to without touching as you draw the graph and line longer and longer

Axis of Symmetry This is a line which separates an image into two halves where each half is a reflection of the other half through the line (compare with **Reflection**)

Binary numbers Numbers in the base 2; they are written using 0's or 1's to represent the different powers of 2, in descending order from left to right, that make up the number

Binomial An expression consisting of two terms

Cardinality The number of **Elements** in a set; some sets are finite (e.g. the solutions to a quadratic equation or the possible ways six cards can be drawn from a pack), and some are infinite (e.g. all the points on a line segment or the set of real numbers)

Central angle A central angle is a positive angle whose vertex is at the centre of the circle

Circumference The length around the entire edge of a circle; it is the maximum **Arc Length** of a circle; the ratio of circumference to diameter is the constant, $\pi = 3,141\ 592\ 693 \dots$

Coefficient A number or symbol multiplied with a variable or an unknown quantity in an algebraic term

Co-interior angles These are the two pairs of angles on the same side of a transversal through two lines, between the two lines; if the two lines are parallel then each pair of angles adds up to 180° and we say they are **Supplementary**

Commutative property Changing the order of **Operation** does not change the answer; addition is commutative, but subtraction is not; multiplication is commutative but division is not

Complementary Angles Angles that add up to 90° , e.g. the two non-right-angles in a right-angled triangle are always complementary

Compound interest Interest is charged on the principal amount and on the existing interest

Concentric circles Circles with different radii that share the same centre

Congruent triangles Triangles that are the same in all respects; the ratios of the lengths of their corresponding sides is 1:1

Constant The known value in an algebraic expression

Consumer Price Index (CPI) Measures changes in the price level of a market basket of consumer goods and services purchased by households

Contraction A contraction is when something is reduced in size by the same factor along one or more directions

Corresponding angles The four pairs of angles in the same positions relative to a transversal cutting through two lines; if the two lines are parallel then each pair of corresponding angles are equal

Deflation When inflation rates drop below 0%, indicating the cost of items has gone down

Diameter A straight line going from one point on the circumference on a circle through the centre to the opposite point on the circumference on the circle

Difference How much bigger or smaller one value is compared to another; obtained by subtraction; compare with **Ratio** and **Multiple**

Dilation A dilation is when something stretches

Distance formula Calculates the distance between two points $(x_1; y_1)$ and $(x_2; y_2)$ shown as follows:
$$\sqrt{(x_2 - x_1)^2 + (y_2 - y_1)^2}$$

Distributive property A number broken into parts and each part is multiplied, the answer is the same as when the number is multiplied as a whole

Dividend (numerator) The part you divide

Division The process of dividing a number into parts to see how many times a number is contained in another

Divisor (denominator) The part you divide with

Domain Set of all possible input values of a function; in practical problems, the physically allowable input values will make up the domain; see **Variable**

Element The members of a set; in number sets, the elements are numbers

Equation This is a kind of mathematical question; and equation results when we want to know which input values will make the output values of two different expressions the same e.g. asking when $4x - 6$ will have the same value as $x^2 - x$ will lead us to a quadratic equation which will give us two possible input values, 2 and 3, for which $4x - 6$ and $x^2 - x$ will have the same outputs (2 and 6 respectively); sometimes one of the expressions is a constant, e.g. $\sin x = -0,23$, in which case we only have to find a value or values of x that we can input into $\sin x$ to output $-0,23$; see **Unknown**

Equiangular triangle All three angles are the same and equal to $180^\circ \div 3 = 60^\circ$; also called an equilateral triangle because all three sides have the same length

Equivalent expressions Algebraic expressions that have the same numerical value (output value) no matter which allowable input value we choose; e.g.

Equivalent numerical expressions Algebraic expressions that have the same numerical values (answers) for all values of the number represented by the letters

Evaluating the expression The process of completing the expression by assigning a value to the variable

Exchange rate The ratio of one currency to another

Expansion Writing a product expression as a sum expression

Exponents Repeated multiplication or division (when the exponent is an integer)

Exterior angle of a polygon An angle that is supplementary to an interior angle; there are always two at any vertex and they are vertically opposite and hence equal

Factorisation Expressing numbers or algebraic expressions as products of their factors

Factor a part of a number which is multiplied by another number to get the original number, e.g. 3 is a factor of 53121

Factors of an expression The parts that are multiplied in an expression

Gradient of a straight line between two coordinate points indicates the slope of the line and whether it is a positive (increasing) or negative (decreasing) slope. We use the following formula to calculate the gradient of a straight line between the points $(x_1; y_1)$ and $(x_2; y_2)$: $m = \frac{y_2 - y_1}{x_2 - x_1}$

Hierarchy in mathematics we mean a way of arranging objects in an order so that an object lower down in the arrangement has all the properties of objects above it in the arrangement; another word that describes this is taxonomy

Hire purchase A legal agreement between a buyer and a seller where something is bought by paying it off in regular (usually monthly) instalments

Horizontal asymptote of a curve A horizontal line, parallel to the x -axis, where the distance between coordinate points on the curve and the asymptote line continually decreases but never becomes zero as the x -coordinates of these points increase (or decrease)

Hyperinflation Very high inflation rate, indicating that the economy is slowing down too much and money cannot keep its value

Hypotenuse The side of a right-angled triangle opposite the right angle **i** Interest per time unit, expressed as a decimal fraction

Imaginary numbers Are numbers that can be written in terms of $\sqrt{-1}$

Infinity bigger than any number we choose; it is represented by ∞ ; a set is infinite if we cannot count the individual elements i.e. no matter how long we take, we will never be able to count them all; e.g. \mathbb{N} , \mathbb{Z} , \mathbb{Q} , \mathbb{R} are all infinite sets

Inflation rate The percentage increase in the price of an item or service; when we speak of inflation we usually mean positive inflation where the cost of items increases over time; a negative inflation rate is called **Deflation**

Intercept A point at which the graph intersects or cut the x - or y -axis

Interior angle of a polygon An angle inside the polygon that has two adjacent sides of the polygon as its arms

Intersect when two lines cut each other; the point where this happens is called the point of intersection of the two lines

Interval A subset of all the numbers between two given numbers called endpoints

Intrinsic value the value that something has because of what it is made up of, or because of its purpose; intrinsic value may be very low even though the commercial value may be high (e.g. a painting by Gerard Sekoto is intrinsically worth very little because paint and canvass are not expensive; however, his paintings may be

worth millions because art collectors attach a high value to his work)

Irrational numbers these are not rational, i.e. they cannot be written as ratios of whole numbers; π and all true surds are irrational numbers; most solutions to trigonometric equations are also irrational; when we have to work with irrational numbers in decimal form we have to round them off to an appropriate number of significant figures (because they are non-terminating, non-recurring decimal fractions)

Isosceles triangle Two of the angles are equal; these angles have to be acute; the sides opposite to the two equal angles are also always equal

Lengths Measures differences in positions along a line that may be straight or curved

Line this is a straight line where both 'ends' continue past any points we can choose, i.e. infinitely in both directions

Line segment This is a straight line that has two ends, i.e. it has a finite length

Manipulating an expression Forming an expression that is equivalent to a given expression

Maximum and minimum points on a graph These are output values on a graph that are bigger than the near-by output values, or smaller

Midpoint formula Finding the midpoint of any line segment between two coordinate points $(x_1; y_1)$ and $(x_2; y_2)$ without drawing a diagram using the formula as follows: $m\left(\frac{x_1 + x_2}{2}, \frac{y_1 + y_2}{2}\right)$

Monomial An expression with one term only

Multiple How many times bigger or smaller, through multiplication, one value is compared to another; we speak of a multiplier; see **Factor**

Multiplicative inverse or reciprocal Is a number that when multiplied by x , yields the multiplicative identity

n Number of time units, over which interest is calculated

Non-terminating fraction A decimal fraction that has an infinite number of digits in its fractional part

Notation we use notation to represent particular ideas in a clear way (especially when expressing them in normal language is not easy to do or to understand); notations are defined and agreed upon (conventions in that sense); notations are made up of symbols and the rules for using them

Number line Each and every real number is a point on a scaled line

Obtuse angled triangle One of the angles is bigger than 90° but smaller than 180° ; both the remaining angles are acute

Operation The action we need to take with the constant and variable values

Opposite leg the leg opposite to an acute angle in a right-angled triangle

Ordered set A set with order, where each element of the set is either above or below any other element of the set; real number sets are all ordered sets

π or π Is the ratio of the circumference of a circle to its diameter $\pi = \frac{\text{circumference}}{\text{diameter}}$

Polynomial Expressions with more than one term

Precision Describes the number of significant figures in a value, the more significant the figures, the greater the precision (compare with **Accuracy**)

Prime Factors All the prime number factors of a number

Prime Numbers Integers greater than 1 that have only two factors (1 and themselves); prime factors are the 'building blocks' of integers because prime factors cannot be factorized further (they are the smallest integer factors of the integer)

Principal value Initial amount invested (P)

Product expression An expression made up of two or more expressions whose separate outputs for given inputs must be multiplied to get the overall output of the expression

Quantity Anything that we can measure or count

Quotient expression or algebraic fraction when two expressions are such that the outputs of one, called the **dividend**, for any input must be divided by the corresponding outputs of the other, the **divisor**

Radian The measure of a central angle that subtends an arc with a length equal to the circle's radius; although we speak of angles measured in radians, the radian is actually unitless (because it is the quotient or ratio of two lengths)

Radius A line segment joining the centre of a circle to a point on the circle; the word radius also refers to the length of the radius; all the points on the circumference of a circle are the same distance, the radius, from the centre

Range Is the set of all output values of a function; the range of output values depends on the **Domain** of input values; see **Variable**

Ratio Tells us how many times bigger (multiplication) or smaller one measurement is compared to another measurement; see **Multiple**; compare with **Difference**

Rational numbers Real numbers that can be written as a ratio of whole numbers, in fractions

Ray A straight line with one end only

Real numbers Numbers we encounter in everyday mathematics dealing with quantities we can measure directly

Recurring fraction A fraction where a series of digits form a pattern that repeats over and over again without end

Reflection when something is flipped over to create a mirror image of it; the line of reflection is the imaginary **Axis of Symmetry** between the original and the reflected image

Revolution has a measure of 360° or $2\pi r$ rad

Right-angled triangle One of the angles is 90° ; both the remaining angles are automatically acute angles, and are **Complementary**

Scalene triangle The interior angles are all different in value; the sides are also always of different lengths

Scale diagram we can make angle (and length) measurements directly on it; it is a scaled representation of something real, or of another diagram

Scientific notation A way of writing a decimal number as a factor between -10 and 10 , multiplied by a power of 10 , only significant figures are shown

Sector Part of a circle enclosed by two radii of a circle and their intercepted arc, a pie-shaped part of a circle

Set a collection of objects, called **Elements**; we mostly deal with number sets

SI International System of Units

Significant figures The digits in a decimal number that form part of the value of the number; see **Precision**

Similar triangles Triangles with the same angle sizes; the ratios of the lengths of their corresponding sides are equal

Simple interest Interest is calculated only on the principal value

Simplest form With exponents, leaving all bases in prime factor form

Simplifying Writing an expression in a convenient way by means of manipulating expressions through addition and subtraction of like terms

Sketch diagram None of the lengths and angles have been drawn with a fixed scale; only their relationships are shown in the diagram

Solution of an equation The value of the input variable that makes the equation a true mathematical statement, i.e. if the value is substituted into each of the two expressions they will produce the same output value

Standard position of an angle We measure angles on a circle starting at the positive horizontal axis and moving anti-clockwise unless instructed otherwise

Subject of the formula Rearranging a formula in order to calculate a value of one of the quantities; when you make a particular variable the subject of the formula you are making it the dependent variable, and all the other variables in the expression, independent variables

Subset A set that has some of the elements of another set in it e.g. the set of integers is a subset of the set of rational numbers

Sum expression When addition/subtraction is the last step in evaluating an algebraic expression

Supplementary angles These are two angles that add up to 180°

Terminating fraction A decimal fraction that has a finite number of decimal digits

Terms of the expression The parts that are added in an expression

Timeline A number line for time

Translation A translation is a movement in one direction without changing orientation, or contracting, or dilating

Transversal Any line that cuts across (transverses) two or more other lines

Trinomial An expression that is a sum of three terms

Turning point If the graph is smoothly curved near its maximum or minimum points we call them turning points

Unknown the value of a variable in a particular situation; usually there are only a few values that an unknown may have, e.g. in an equation that has a linear expression $= 0$ the unknown may have at most one value; in an equation that has a quadratic expression $= 0$ the unknown may have at most two values

Variable A quantity that does not have a fixed value; in a function, we call the input variable the independent variable, and the output variable, the dependent variable; the value of the independent variable may be any number in a particular **Domain**, while the value of the output variable may be any number in the corresponding **Range**; compare with **Unknown**

Vertex A point where two rays meet or where two lines cross

Vertical asymptote of a curve A vertical line parallel to the y -axis where the distance between coordinate points on the curve and the asymptote line continually decreases but never becomes zero as the y -coordinates of these points increase (or decrease)

Vertically opposite angles The pair of angles on the opposite sides of a **Vertex**; they are always equal

x -intercept The point where the graph cuts the x -axis (also called the horizontal axis)

y -intercept The point where the graph cuts the y -axis (also called the vertical axis)

CHAPTER 1 INTRODUCTION ANSWERS

1.		Explanation/meaning	Example(s)
(a)	Product	The answer you get when you multiply two or more numbers	$3 \times a = 3a$; $7 \times 3 = 21$
(b)	Quotient	The answer you get when you divide numbers	$\frac{12}{2} = 6$; $18 \div 9 = 2$
(c)	Sum	The answer you get when you add two or more numbers	$4 + 5 = 9$
(d)	Difference	The answer you get when you subtract a number from another number	$4 - 2 = 2$
(e)	Factor	A number that multiplies with another number to produce a product	4×2 ; $(c + 1)(d - 1)$
(f)	Additive inverse	A number that is added to another number that yields the answer zero	$2 + (-2) = 0$
(g)	Multiplicative inverse	The number by which a given number must be multiplied to get a result of one.	$2 \times \frac{1}{2} = 1$
(h)	Identity for addition	Zero added to any number is the number itself	$3 + 0 = 3$
(i)	Identity for multiplication	Any number multiplied by 1 yields the number itself	$9 \times 1 = 9$
(j)	Coefficient	The number that is multiplied by a variable	$3x^2$ where 3 is the coefficient
(k)	Solution	The value of a variable that makes the given mathematical statement to be true	$2x + 8 = 14$ has one solution $x = 3$
(l)	Reciprocal	The number by which a given number must be multiplied to get a result of one.	$2 \times \frac{1}{2} = 1$
(m)	Input variable	An independent variable in a function that determines the value of the output amount	In the function $r = t^2 + 2t - 1$, t is the input variable
(n)	Output variable	A dependent variable in a function that is produced by a specific input variable	In the function $r = t^2 + 2t - 1$, r is the output variable

2.	Expression	Type of expression	Symbol used to represent the variable	Constant	Coefficient of
(a)	$3x^2 - 7x + 9$	Trinomial	x	9	x is -7
(b)	$5s^3 - 11$	Binomial	s	-11	s^3 is 5
(c)	$-1, 2t + \pi$	Binomial	t	π	t is $-1, 2$
(d)	$105k$	Monomial	k	0	k is 105
(e)	$11 - p + p^3$	Trinomial	p	11	p^3 is 1

4.	Base quantity	SI (International System of Units) base units	
		Name	Symbol
	length	metres	m
	mass	kilograms	kg
	time	seconds/minutes	s/m
	electric current	Ampere	A

5. (a) kilograms (kg) (b) cubic meters (m³) (c) meters (m) (d) kilometers (km) (e) liters (l)

8. (a) 1 815 (b) 7 030 (c) 1 700
9. (a) Expressions are equivalent
(b) Expressions are not equivalent
10. (a) Expressions are equivalent
(b) Expressions are equivalent
12. (a) $x(a + b)$ (b) $3(2x - 1)$ (c) $4(1 + 4x)$
(d) $x(7x - 1)$ (e) $5(x - 3)$ (f) $7(2 - x^2)$
(g) $3(x - 1)$ (h) $3(5x - 2)$
13. (a) $(a + 3)(a + 1)$ (b) $2(2x^2 + 4x + 1)$
(c) $(x + 1)(x + 1)$ (d) $(a + b)(c + d)$
(e) $(a + b)(x + 1)$ (f) $3x(5x - 2)$
14. (a) $a^2 - b^2$ (b) $a^2 + 2ab + b^2$
(c) $a^2 - 2ab + b^2$ (d) $p^2 + 2pq + q^2$
(e) $p^2 - 2pq + q^2$ (f) $p^2 - q^2$
(g) $ac + ad + bc + bd$ (h) $ac - ad + bc - bd$
(i) $x^2 + 6x + 9$ (j) $x^2 - 9$
(k) $x^2 - 6x + 9$
15. (a) $(x - 2)(x + 2)$ (b) $(3 - x)(3 + x)$
(c) $(x - 11)(x + 11)$ (d) $(11 - x)(11 + x)$
(e) $(13 - 2x)(13 + 2x)$ (f) $(2x - 13)(2x + 13)$
(g) $(5 - x)(5 + x)$ (h) $(x - 5)(x + 5)$
(i) $(p - 1)(p + 1)$ (j) $(1 - p)(1 + p)$
18. (a) 23 385 (b) 199 (c) 1 999
23. (a) 417,1 (b) 79,35 (c) 356,14 (d) 23,45
24. (a) 78 (b) 79 (c) 70 (d) 73
25. 4,5
26. (a) $9 \times 10^3 + 8 \times 10^2 + 7 \times 10 + 6$
 $9x^3 + 8x^2 + 7x + 6$, with $x = 10$
(b) $3 \times 10^2 + 5 \times 10 + 7$
 $3x^2 + 5x + 7$, with $x = 10$
(c) $2 \times 10^3 + 4 \times 10^2 + 6 \times 10 + 8$
 $2x^3 + 4x^2 + 6x + 8$, with $x = 10$
(d) $1 \times 10^2 + 2 \times 10 + 3$
 $x^2 + 2x + 3$, with $x = 10$
27. (a) $11x^3 + 9x^2 + 7x + 5$ (b) $9x^2 + 11x + 9$
(c) $9x^2 + 12x + 10$ (d) $9x^2 + 4x + 4$
(e) $6x^2 + 8x + 5$
28. (a) $2x - 1$ and $x^2 - x - 6$
(b) 2 and $-x^2 + 1$
(c) $11,2x + 3$ and $12x^2 + 3,6x$
(d) $x + 10$ and $0,21x^2 + 5,4x + 24$
(e) $3x$ and $2x^2 - x - 1$
29. (a) (No of days) = $7 \times$ (No of weeks)
(b) (No of minutes) = $60 \times$ (No of hours)
(c) (No of learners) = $25 \times$ (No of teachers)

29. (a)

Number of weeks	1	2	3	4	5	12	24	33	52
Number of days	7	14	21	28	35	84	168	231	364

(b)

Number of hours	1	2	3	6	18	24	36	48	60	72
Number of minutes	60	120	180	360	1 080	1 440	2 160	2 880	3 600	4 320

(c)

Number of learners	100	200	300	350	405	600	660	809	1 000	1 800
Number of teachers	4	8	12	14	16	24	26	32	40	72

30.

x	-10	-5	-1	0	8	14	20	23	50
$5x + 3$	-47	-22	-2	3	43	73	103	118	253

32. Equation

33. (a) No. They do not give the same output value for the same value of x .
(b) No. The two expressions are only equal for one value of x .
(c) The two expressions yield the same answer.

34. (a) No (b) Impossible

36. $\frac{73}{10}$

37. 7,3

41. (a) $12 - 5 \times 2 + 1 = 3$ (b) $18 - 12 + 3 \times 2 = 12$ (c) $24 \div 4 - 2 + 3 = 7$ (d) $12 \div 4 + 6 + 2 = 11$
(e) $60 + 20 - 50 = 30$

42. (a) $12 \div 3 + 1 = 5$ (b) $20 \div 5 \div 2 + 3 = 5$
 (c) $24 \div 6 \times 2 - 2 + 4 = 10$ (d) $8 \times 3 - 8 \times 3 = 8 - 8 - 3 + 3$

43. 11; 22; 33; 44; 55

44.

Term position	1	2	3	4	5	10	17	23	35	100
Term	3	6	9	12	15	30	51	69	105	300

45. (a) -60 (b) -180 (c) -370

46. 2; 6; 18; 54; 162; 486; 1 458; 4 374

47. (a) 2; 6; 18

(b)

Term position	1	2	3	13	25	46	57	88	91
Term	2	6	18	1 062 882	$5,648 \times 10^{11}$	$5,91 \times 10^{21}$	$1,05 \times 10^{27}$	$6,47 \times 10^{41}$	$1,75 \times 10^{43}$

49. (a) 125 (b) 243 (c) 2,343 (d) 2,25 (e) -9 (f) -9 (g) 9 (h) -9

CHAPTER 2 NUMBER SYSTEMS ANSWERS

EXERCISES

- $\mathbb{Z} \subseteq \mathbb{Q}$ The set of integers is a subset of the set of rational numbers.
 - $\mathbb{Q} \subseteq \mathbb{R}$ The set of rational numbers is a subset of the set of real numbers.
 - $\mathbb{Z} \subseteq \mathbb{R}$ The set of integers is also a subset of the set of real numbers.
 - $0,56 \in \mathbb{Q} - \mathbb{Z} \wedge \mathbb{R} - \mathbb{Z}$ 0,56 is a non-integer rational number and also a real number but it is not an integer.
 - $7 \in \mathbb{Z}^+$ 7 is a positive integer and also not zero.
 - $\pi \in \mathbb{R} - \mathbb{Q}$ The number pi = 3,141 592 653 589 ... is irrational.
 - $2 \in \mathbb{N}$ 2 is a natural number, a counting number, a rational number, and a real number. It is neither a negative integer nor an irrational number.
 - $0,578\ 5 \in \mathbb{Q} - \mathbb{Z}$ 0,578 5 non-integer rational number and a real number.
 - $\sqrt{3} \in \mathbb{R} - \mathbb{Q}$ $\sqrt{3}$ is an irrational number and a real number.
 - $\sqrt{2} \in \mathbb{R} - \mathbb{Q}$ True surds are never rational.
 - $\sqrt{-1} \notin \mathbb{R}$ $\sqrt{-1}$ is a non-real number
- | | | |
|----------------|--------------|----------------|
| (a) Integer | (b) Rational | (c) Irrational |
| (d) Irrational | (e) Rational | (f) Irrational |
| (g) Irrational | (h) Integer | (i) Rational |
| (j) Integer | (k) Rational | (l) Rational |
| (m) Irrational | (n) Non-real | (o) Irrational |
| (p) Irrational | (q) Rational | (r) Irrational |
- | | | |
|---------------------------------------|--|--|
| (a) $\mathbb{Q} \subseteq \mathbb{R}$ | (b) $\mathbb{N} \subseteq \mathbb{R}$ | (c) $\mathbb{Q}' \subseteq \mathbb{R}$ |
| (d) $\mathbb{Q} \subseteq \mathbb{R}$ | (e) $\mathbb{Q} \subseteq \mathbb{R}$ | (f) $\mathbb{Q} \subseteq \mathbb{R}$ |
| (g) $\mathbb{Z} \subseteq \mathbb{Q}$ | (h) $\mathbb{Q}' \subseteq \mathbb{R}$ | |
- | |
|---|
| (a) The set of numbers stated |
| (b) The set of integers between -2 and 11, including -2 and excluding 11 |
| (c) y is any rational number between and excluding $\frac{1}{3}$ and $\frac{4}{3}$ |
| (d) Real numbers between $-\sqrt[3]{5}$ and 10,98, excluding $-\sqrt[3]{5}$ and including 10,98 |
| (e) x is any counting number from 500 to 550 |
- | |
|--|
| (a) $\{x \in \mathbb{R} \mid -10 < x < -5\}$ |
| (b) $\{x \in \mathbb{R} \mid -10 < x \leq -5\}$ |
| (c) $\{x \in \mathbb{R} \mid -10 \leq x \leq -5\}$ |
| (d) $\{x \in \mathbb{Z} \mid x < 7\}$ |
| (e) $\{x \in \mathbb{N} \mid x < 7\}$ |

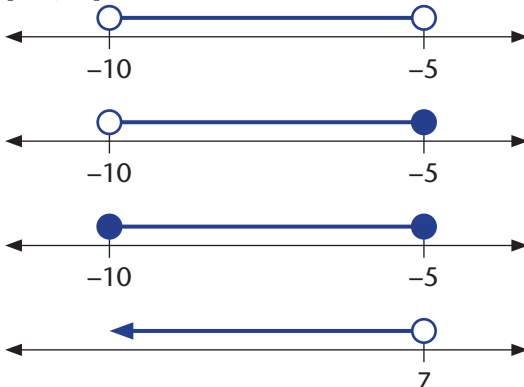
- | |
|--|
| (a) $(-10; -5)$
$(-10; -5]$
$[-10; -5]$ |
| (b)  |
- | | | |
|---------------------|---------------|--------|
| 5(a) 7 | 5(b) 13 | 5(c) 2 |
| 5(d) infinite | 5(e) infinite | |
| 6(a) - (e) infinity | | |
- | | |
|-----------------------|--------------------|
| (a) (i) 22,891 452 78 | (ii) 22, 891 452 8 |
| (iii) 22,891 453 | (iv) 22,891 45 |
| (b) (i) 21,115 7 | (ii) 21,116 |
| (iii) 21, 12 | (iv) 21,1 |
| (c) (i) 58,453 451 7 | (ii) 58, 45 |
| (iii) 58, 5 | (iv) 58 |
- | | | |
|--------------------------------|----------------------------|-----------------------|
| (a) $\frac{16}{100}$ | (b) $\frac{15}{90}$ | (c) $\frac{1}{9}$ |
| (d) $\frac{125}{1\ 000}$ | (e) $\frac{2}{9}$ | (f) $\frac{1}{16}$ |
| (g) $\frac{7}{9}$ | (h) $5 \frac{125}{1\ 000}$ | (i) $\frac{235}{999}$ |
| (j) $\frac{794\ 659}{99\ 990}$ | | |
- | | |
|-----------------------|-------------------|
| (a) $0,\dot{3}$ | (b) 4,875 |
| (c) 0,275 714 285 | (d) 7,615 384 615 |
| (e) 0,687 5 | (f) 30,13 |
| (g) 78, 272 727 27... | (h) 9,916 666 667 |
| (i) 47,272 727 27.... | (j) 1,916 666 667 |
- | | |
|---|---------------------|
| (a) $1,414^2 = 1,999\ 396$ and $1,415^2 = 2,002\ 225$ | (c) 1,997 and 1,999 |
| (b) 1,996 6 and 1,999 3 | |
- | | |
|---------------------|---------------------|
| (a) between 1 and 2 | (b) 2 |
| (c) between 2 and 3 | (d) between 2 and 3 |
| (e) between 2 and 3 | (f) between 2 and 3 |
| (g) 3 | (h) between 3 and 4 |
| (i) between 3 and 4 | (j) 5 |
| (k) between 1 and 2 | (l) 2 |
| (m) between 2 and 3 | (n) between 2 and 3 |
| (o) between 4 and 5 | (p) between 2 and 3 |
| (q) between 4 and 5 | (r) between 2 and 3 |

18. (a) 1 (b) 3 (c) 7 (d) 15
 (e) 2 (f) 6 (g) 14 (h) 5
 (i) 9 (j) 17 (k) 81 (l) 70
 (m) 97 (n) 119
19. (a) 1101111 (b) 1110000 (c) 1110001
 (d) 1111111 (e) 10000001 (f) 101101101
 (g) 1010 (h) 1100100 (i) 1111101000
 (j) 110000000 (k) 111100100 (l) 110000001
 (m) 111110100 (n) 1001101111
20. (a) $11111 > 11110$ (b) $11111 < 100000$
 (c) $10101 > 10010$ (d) $110010 < 110100$
 (e) $101010 < 101101$ (f) $1001011 < 1010101$
23. (a) 11 (b) 101 (c) 110 (d) 111
 (e) 111 (f) 1111 (g) 1110 (h) 1111
24. (a) 101 (b) 110 (c) 1010 (d) 1110
 (e) 11001 (f) 10111 (g) 100110 (h) 101000
 (i) 110000 (j) 1011101 (k) 100 (l) 1000
 (m) 1000 (n) 10000 (o) 100000
 (p) 100001 (q) 100011 (r) 100111
25. (a) 1 (b) -1 (c) 10 (d) 11
 (e) -11 (f) 11 (g) 1000 (h) 1100
 (i) 1110 (j) 1001 (k) 10 (l) 110
 (m) 100 (n) 1000 (o) 11110 (p) 11101
 (q) 11011 (r) 10111
27. (a) 1001 (b) 10010 (c) 100100
 (d) 1111 (e) 1000 (f) 1010
 (g) 1000001 (h) 110001 (i) 1011011
 (j) 111111 (k) 10011010 (l) 1110101
 (m) 100101011 (n) 11100001 (o) 100111011
 (p) 1000110111 (q) 10100011001
 (r) 100101011101
28. (a) 10 (b) 1001 (c) 10 rem 1
 (d) 1 (e) 101 (f) 111 rem 1
 (g) 10 rem 1 (h) 11 (i) 1011
 (j) 100 (k) 111 (l) 111
 (m) 1010 rem 1
29. (a) Imaginary (b) Real (c) Imaginary
 (d) Real (e) Imaginary (f) Real
 (g) Imaginary (h) Real (i) Real
 (j) Real

CONSOLIDATION EXERCISES

1. (a) integer (b) rational (c) irrational
 (d) rational (e) rational (f) natural
 (g) non-real (h) irrational
3. (a) $\frac{3}{4}$ (b) $\frac{97}{99}$ (c) $\frac{1}{40}$
 (d) $\frac{126}{125}$ (e) $4\frac{14}{33}$ or $\frac{438}{99}$ (f) $\frac{11}{8}$
 (g) $\frac{9}{50}$ (h) $\frac{12}{99}$ (i) $\frac{3}{4}$
 (j) $\frac{25}{8}$ (k) $\frac{871}{999}$ (l) $\frac{223}{99}$
4. (a) 0,857 421 857 (b) 0,875
 (c) 0,888... (d) 0,9
 (e) 0,353 5... (f) 0,015 15...
 (g) 0,666 6... (h) 0,066 66...
 (i) 0,366 66... (j) 3,857 142 857
 (k) 6,466 666... (l) 3,477 272 727...
5. (a) between 2 and 3 (b) between 3 and 4
 (c) between 5 and 6 (d) between 2 and 3
 (e) between 3 and 4 (f) between 2 and 3
6. 1; 10; 11; 100; 101; 110; 111; 1000; 1001; 1010
 1011; 1100; 1101; 1110; 1111; 10000; 10001; 10010;
 10011; 10100
7. (a) 1 (b) 7 (c) 3 (d) 2
 (e) 6 (f) 9
8. (a) 1110000 (b) 101101
 (c) 1011 (d) 11000110101
 (e) 110100100 (f) 1101
9. (a) 1000 (b) 11 (c) 1000
 (d) 1001 (e) 10011 (f) -1
 (g) 1 (h) -10 (i) 10100
 (j) 11100
10. (a) 111 (b) 10 (c) 1100
 (d) 1110 (e) 1000110 (f) 10
 (g) 1 rem 1 (h) 1111 (i) 1001
 (j) 111

CHAPTER 3 EXPONENTS ANSWERS

EXERCISES

1.	Current multiplier at each dynode	Number of dynodes	Combined current multiplier in expanded form	Combined current multiplier in exponential form	Combined current multiplier in numerical form
	2	5	$2 \times 2 \times 2 \times 2 \times 2$	2^5	32
	2	10	$2 \times 2 \times 2 \times 2 \times 2 \times 2 \times 2 \times 2 \times 2 \times 2$	2^{10}	1 024
	3	5	$3 \times 3 \times 3 \times 3 \times 3$	3^5	243
	4	5	$4 \times 4 \times 4 \times 4 \times 4$	4^5	1 024
	4	9	$4 \times 4 \times 4 \times 4 \times 4 \times 4 \times 4 \times 4 \times 4$	4^9	262 144
	6	5	$6 \times 6 \times 6 \times 6 \times 6$	6^5	7 776
	3	9	$3 \times 3 \times 3 \times 3 \times 3 \times 3 \times 3 \times 3 \times 3$	3^9	729
	9	3	$9 \times 9 \times 9$	9^3	729
	5	6	$5 \times 5 \times 5 \times 5 \times 5$	5^6	15 625
	1,5	6	$1,5 \times 1,5 \times 1,5 \times 1,5 \times 1,5 \times 1,5$	$1,5^6$	11,390 625
	1	(x)	$1 \times 1 \times 1 \dots$ (x number of times)	1^x	1

2. (a) One layer: effective transmission is just 0,3, which is $0,3^1$ in exponential form (hence having $x^1 = x$ is sensible)
 (b) Zero layers should mean no change in sound intensity; so transmission factor is 1; defining $0,3^0 = 1$ therefore makes sense
3. The circumference of the small wheel is a third of that of the big wheel. Hence for every turn of the big wheel the small wheel will have to turn three times (assuming zero slippage)
 (a) $\frac{1}{3}$ or 3^{-1} or $0,3$
 (b) They are reciprocals
4. (a) $3 \times 3 \times 3 \times 3$ or 3^4 (which is 81 times faster than the driver)
 (b) $\frac{1}{3} \times \frac{1}{3} \times \frac{1}{3} \times \frac{1}{3} = (\frac{1}{3})^4 = \frac{1}{3^4} = 3^{-1} \times 3^{-1} \times 3^{-1} \times 3^{-1} = (3^{-1})^4 = 3^{-4}$ which are all equivalent
 (c) $3 \times \frac{1}{3} = 3 \times 3^{-1} = 3^0 = 1$ doesn't matter which of the two big pulleys is the driver
 (d) $\frac{1}{3} \times 3 = 3^{-1} \times 3 = 3^0 = 1$ again, it doesn't matter which of the small pulleys is the driver
 (e) Reversing the individual belt drives is the same as reciprocating (inverting) the speed factor i.e. the same as raising the speed factor to the power of -1 . So defining x^{-1} makes sense.
5. The following is a guide to this question:
 A: driver leftmost: $3 \times \frac{1}{3} \times 3;$ $3 \times 3^{-1} \times 3;$ $3^{1-1+1};$ $3^1;$ 3
 B: driver leftmost: $3 \times 3 \times \frac{1}{3};$ $3 \times 3 \times 3^{-1};$ $3^{1+1-1};$ $3^1;$ 3
 Etc.
 Observe: the different forms are all equivalent
 A: driver rightmost: $\frac{1}{3} \times 3 \times \frac{1}{3};$ $3^{-1} \times 3 \times 3^{-1};$ $3^{-1+1-1};$ $3^{-1};$ $\frac{1}{3}$
 B: driver rightmost: $3 \times \frac{1}{3} \times \frac{1}{3};$ $3 \times 3^{-1} \times 3^{-1};$ $3^{-1-1+1};$ $3^{-1};$
- Focus on the equivalence of the different forms
6. (a) 7^{6+6} (b) 7^{14-2} (c) $7^{6 \times 2}$
7. $3^6 \times 5^9 = (3 \times 5)^6 \times 5^3 = (3^2 \times 5^2)^3 \times 5^3 = (3^2 \times 5^3)^3$ are some

8. (a) Driver top left in all diagrams:
 Single belt drive with speed factor 4
 Compound belt drive with speed factor
 $= 4 \times 4 \times 4 \times 4 = 4^4$
 Effective speed factor $= 4^1 \times 4^4 = 4^5$

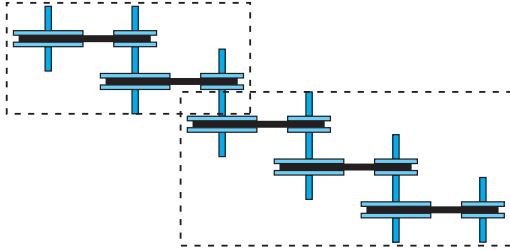

Compound belt drive with effective speed factor 4^2
 Compound belt drive with effective speed factor 4^3
 Effective speed factor $= 4^2 \times 4^3 = 4^5$

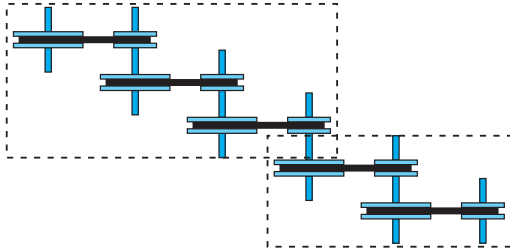

Compound belt drive with speed factor 4^3
 Compound belt drive with speed factor 4^2
 Effective speed factor $= 4^3 \times 4^2 = 4^5$

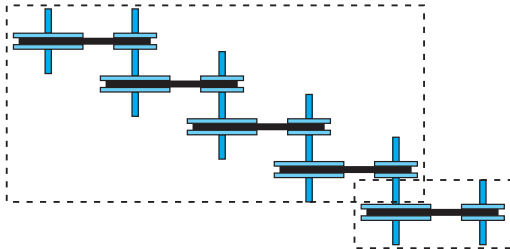

Compound belt drive with speed factor 4^4
 Belt drive with speed factor 4
 Effective speed factor $= 4^4 \times 4^1 = 4^5$

- (b) Driver top left:

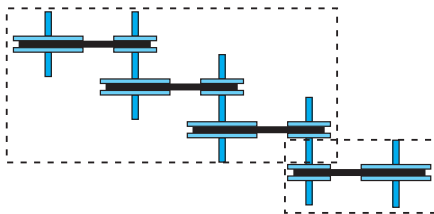

Compound belt drive with speed factor
 $5 \times 5 \times 5 = 5^3$
 Belt drive with speed factor $\frac{1}{5} = \frac{1}{5^1}$
 Effective speed factor $= 5^3 \times \frac{1}{5^1} = \frac{5^3}{5^1} = 5^{3-1} = 5^2$

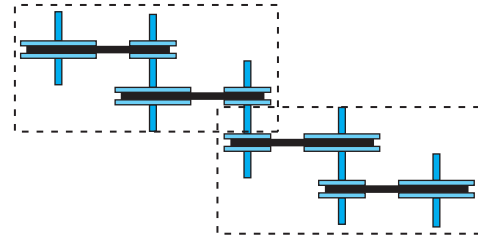

Compound belt drive with speed factor
 $5 \times 5 = 5^2$

Compound belt drive with speed factor
 $\frac{1}{5} \times \frac{1}{5} = \frac{1}{5^2}$

Effective speed factor $= 5^2 \times \frac{1}{5^2} = \frac{5^2}{5^2} = 5^{2-2} = 5^0$

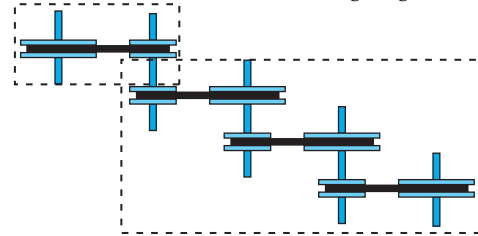

Belt drive with speed factor $5 = 5^1$

Compound belt drive with speed factor
 $\frac{1}{5} \times \frac{1}{5} \times \frac{1}{5} = \frac{1}{5^3}$

Effective speed factor $= 5^1 \times \frac{1}{5^3} = \frac{5^1}{5^3} = 5^{1-3} = 5^{-2}$

- (c) Driver at top left:

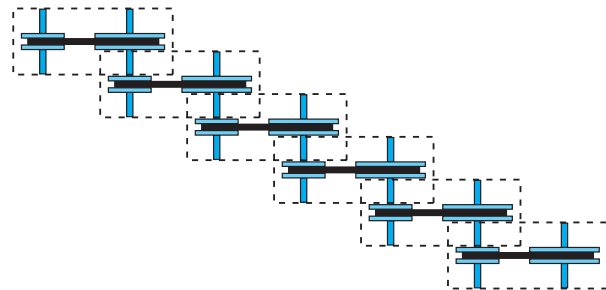

Effective speed factor $= (0,1)^6 = 0,1^{1 \times 6}$

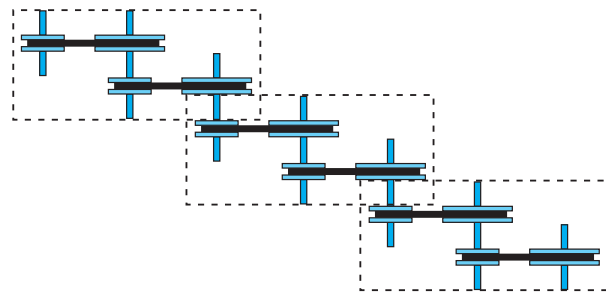

Effective speed factor $= (0,1)^3 = 0,1^{2 \times 3}$

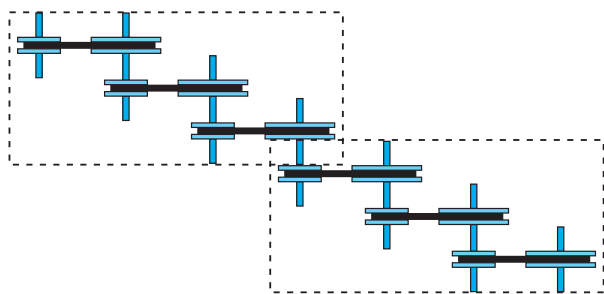

Effective speed factor = $(0,1^3)^2 = 0,1^{3 \times 2}$

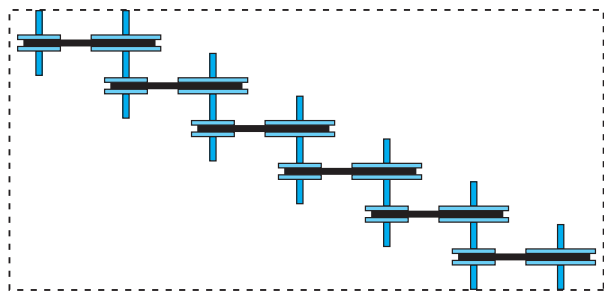

Effective speed factor = $(0,1^6)^1 = 0,1^{6 \times 1}$

(d)

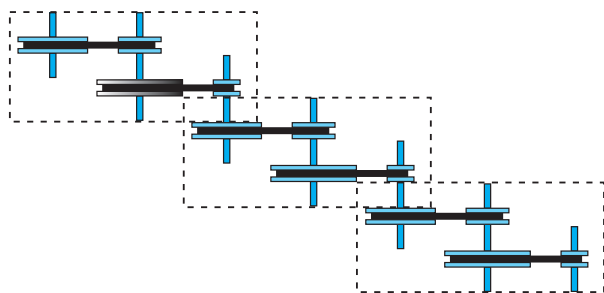

Each of the three compound drives has speed factor 2×5

Effective speed factor = $(2 \times 5)^3$

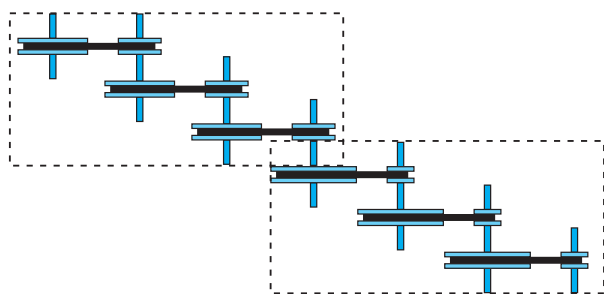

This compound belt drive has effective speed factor $2 \times 2 \times 2 = 2^3$

This compound drive has effective speed factor $5 \times 5 \times 5 = 5^3$

Effective speed = $(2^3) \times (5^3)$

The two compound belt drives are equivalent since they both give the same effective speed factor: $(2 \times 5)^3 = 2 \times 5 \times 2 \times 5 \times 2 \times 5 = 2 \times 2 \times 2 \times 5 \times 5 \times 5 = 2^3 \times 5^3$

9. (a) Correct (b) Incorrect
(c) Correct (d) Correct
10. (a) 8×3^4 (b) Not (c) 81×8
(d) $18 \times 4 \times 3^2$ (e) $18 \times 12 \times 3$ (f) $3^4 \times 2^3$
(g) Not (h) $4^2 \times 9^2 \div 2$ (i) $6^4 \times 26^4 \div 2$
(j) 3×6 (k) $18^3 \div 3^2$ (l) 2×18^2
(m) 648
11. (a) $(5)^{2+7}; 5^9; 5^3 \times 5^6; 5^4 \times 5^5; 5^8 \times 5^1$
(b) $8^8; (2^3)^8; 2^{24}; (2^4)^6; 2^{16} \times 2^8$
(c) $(x)^{5+4}; x^9; x^8 \times x^1; x^7 \times x^2; x^6 \times x^3$
(d) $64^{p+4}; 6^{4p} \times 6^4; 6^{4p} \times 6^2 \times 6^2; (6^{2p} + 2)^2;$
 $6^{2p} \times 6^{2p} \times 6^3 \times 6^1$
(e) $4^3; 4^{5-2}; 2^6; (2^3)^2; 2^2 \times 2^2 \times 2^2$
(f) $\frac{7^5}{7^4}; 7^{5-4}; 7^1; 7^5 \times 7^{-1}; \frac{16\ 807}{2\ 401}$
(g) $\frac{y^8}{y^6}; y^2; y^{8-6}; y \times y; y^8 \times y^{-6}$
(h) $\frac{2^{3p} \times 2^3}{2^p \div 2^2}; 2^{3p+3-(p-2)}; 2^{2p+5}; 2^{2p} \times 2^5;$
 $2^{3p} \times 2^3 \div (2^p \times 2^{-2})$
(i) $2^{3 \times 4}; 2^{12}; 2^6 \times 2^6; (2^3)^2 \times (2^3)^2; 8^2 \times 8^2$
(j) $(\frac{1}{x^3})^{-5}; 1x^{-15}; x^{15}; x^{12} \times x^3; x^{10} \times x^5$
(k) $3^{2(x-3)}; 3^{2x-6}; 3^{2x} \div 3^6; 9^x \div 9^3; (\frac{3^x}{3^3})^2$
(l) $7^{-6}; \frac{1}{7^6}; (\frac{1}{7^3})^2; (\frac{1}{7^2})^3; (7^{-3})^2$
(m) $5^7 \times 9^2; 5^7 \times 81; 5^3 \times 5^4 \times 3^4; 78\ 125 \times 81;$
 $6\ 328\ 125$
(n) $2^3 \times 2^2; 2^{3+2}; 2^5; (2^1)^5; 8 \times 4$
(o) $x^3 \times x^2 \times y \times y; x^3 \times x^2 \times y^2; x^3 \times (x \times y)^2;$
 $x^4 \times x \times y^2; x^3 \times x \times x \times y \times y$
(p) $(3 \times 2)^2 \times 5^2; 3^2 \times 2^2 \times 5^2; (3 \times 2 \times 5)^2; 30^2; 900$
12. (a) 2^8 (b) 2^8
(c) 2^8 point out that (a), (b) and (c) are the same because...
(d) already in simplest form
(e) $2^5 + 2^4 = 2 \cdot 2^4 + 2^4 = 2^4(2 + 1) = 2^4 \cdot 3$
(f) 2^4 (g) $\frac{1}{2^7}$
(h) $\frac{1}{2^7}$ same as (g) because
(i) $\frac{2}{3^2 \cdot 5}$ (j) $\frac{1}{2 \cdot 3^2 \cdot 5}$ (k) 1 (l) 5^{25}
(m) $2^6 \cdot 3^3$ (n) $\frac{1}{2^2}$ (o) 1 (p) $2^6 3^6$
(q) $\frac{2 \cdot 5}{3}$ (r) 2^3 (s) 3^3 (t) $3 \cdot 5^4$
(u) 2 (v) $\frac{2^2}{3^3}$ (w) $\frac{2^5}{3^5}$ (x) $\frac{2}{3 \cdot 5}$
13. (a) $p^6 q^6$ (b) $p^6 q^6$ (c) $\frac{1}{3a^2}$ (d) 3^{2m}
(e) $3^4 a^9$ (f) $2^4 p^2$ (g) 2^5 (h) 3^x
(i) $\frac{1}{2^2}$ (j) $\frac{7ab}{2c}$ (k) $\frac{5}{2}$ (l) $\frac{5^2}{3^4}$
(m) $\frac{3b^4}{2^3}$ (n) 1

14. (a) 3 (b) 3 (c) 6 (d) 2
 (e) 1 (f) 0 (g) -9 (h) 3 or -3
 (i) -2 (j) 4 (k) 9 (l) 1
 (m) -2 or -3 (n) 3 (o) -0,5 (p) $\frac{1}{3}$
 (q) $-\frac{3}{4}$ (r) No solution
 (s) No solution (t) No solution

15. sound intensity in control room

$$= \text{sound intensity in studio} \times 0,1^{\text{number of layers}}$$

$$(5 \times 10^{-7}) = (5 \times 10^{-3}) \times 0,1^n$$

$$0,1^n = \frac{5 \times 10^{-7}}{5 \times 10^{-3}}$$

$$= 10^{-4}$$

$$= (10^{-1})^4$$

$$= 0,1^4$$

$$n = 4$$

You may have noticed that there is a factor $\frac{1}{10\,000}$ change in sound intensity and deduced that there are 4 layers. This is excellent.

16. (a) 8 s since $50\% = \frac{1}{2}$
 (b) Either see that $12,5\% = 0,125 = \frac{1}{8} = \left(\frac{1}{2}\right)^3$ and hence that it will take $3 \times 8 = 24$ s, or set up and solve an equation:
 charge later = charge at start $\times 0,5^{\text{number of periods}}$
 $12,5\% = 100\% \times 0,5^n$
 $0,5^n = 0,125 = 0,5^3$
 $n = 3$
 So it will take 3 periods of 8 s = 24 s.

- (c) charge later = charge at start $\times 0,5^{\text{number of periods}}$

$$3,125\% = 100\% \times 0,5^n$$

$$0,5^n = \frac{3,125}{100}$$

$$\left(\frac{1}{2}\right)^n = \frac{1}{32} \quad [100 \div 3,125 = 32]$$

$$= \frac{1}{2^5}$$

$$= \left(\frac{1}{2}\right)^5$$

$$n = 5$$

So it will take $5 \times 8 = 40$ s for the charge to decrease to 3,125% of the initial value.

Another way: Each period the % halves:

$n = 0$	100%
$n = 1$	50%
$n = 2$	25%
$n = 3$	12,5%
$n = 4$	6,25%
$n = 5$	3,125%

- (d) This one is tough (there is no way they can solve it by setting up an equation). You have to try to get clarity by rolling up your sleeves and seeing how many periods gets them close to 1%.

Using the table above showing the % for each period in (c) above, you can see that after 6 periods, there will be $\frac{1}{64} = 1,56\%$ of the charge and after 7 periods there will be $\frac{1}{128} = 0,78\%$.

So somewhere between $6 \times 8 = 48$ s and $7 \times 8 = 56$ s.

17. (a) $0,2 \times 3^n = 48,6$

$$3^n = 243$$

$$= 3^5$$

$$n = 5$$

Makes no difference because the speed factors are all multiplied with each other and changing the order of multiplication doesn't change the result.

18. $\left(\frac{1}{2}\right)^n = \frac{1,50}{3072}$

$$2^n = \frac{3072}{1,50}$$

$$= 2048$$

$$= 2^{11}$$

$$n = 11$$

19. (a) 8×10^3 (4 s.f. or 1 s.f. depending on context)
 (b) 8×10^0 (1 s.f.) (c) 8×10^{-3} (1 s.f.)
 (d) 1×10^5 (6 s.f.) (e) $3,652\,5 \times 10^2$ (5 s.f.)
 (f) $2,34 \times 10^5$ (3 s.f.) (g) $4,506 \times 10^5$ (7 s.f.)
 (h) $9,600 \times 10^{-14}$ (4 s.f.)
 (i) $1,673 \times 10^{-27}$ kg (4 s.f.)
 (j) $9,454\,256 \times 10^{13}$ km (7 s.f.)
 (k) $7,3 \times 10^{-15}$ m (2 s.f.)
 (l) $1,3 \times 10^{-10}$ m (2 s.f.)
 (m) roughly $10^{-10} \div 10^{-15}$ which is 10^5 or a hundred thousand times greater
 (n) 2×10^{17} kg/m³ (1 s.f. – the zeros clearly cannot be significant)
 (o) $1,932\,0 \times 10^1$ kg/m³ (5 s.f. the zero is clearly deliberate)
 (p) roughly 10^{-16} or one ten million billionth
20. (a) $2,52 \times 10^9$ (rounded to 2 s.f.: $2,5 \times 10^9$)
 (b) 7×10^{-3} (rounded to 2 s.f.: $7,0 \times 10^{-3}$)
 (c) $9,72 \times 10^1$ (rounded to 2 s.f.: $9,7 \times 10^1$)
 (d) $6,75 \times 10^{-9}$ (rounded to 2 s.f.: $6,8 \times 10^{-9}$)
 (e) -5×10^0 (rounded to 2 s.f.: $-5,0 \times 10^0$)
 (f) $6,00 \times 10^3$
 (g) $3,0 \times 10^{-3}$
 (h) $1,25 \times 10^3$ (rounded to 2 s.f.: $1,3 \times 10^3$)

22. (a) $3,80 \times 10^3$ kW (b) $3,80 \times 10^6$ W
 (c) $3,80 \times 10^{-3}$ GW (d) $5,7 \times 10^3$ mA
 (e) $5,7 \times 10^6$ nA (f) $1,8 \times 10^{-2}$ mm
 (g) $1,8 \times 10^{-5}$ mm (h) $1,8 \times 10^{-8}$ m
 (i) $1,8 \times 10^{-11}$ km (j) $1,8 \times 10^2$ Å
 (k) $1,75 \times 10^3$ mg (l) $1,75 \times 10^1$ mg
 (m) $1,75 \times 10^{-1}$ dag (n) $1,75 \times 10^{-2}$ mg
23. (a) 200 mm^2 (b) 300 cm^2
 (c) $5 \times 10^6 \text{ mm}^2$ (d) $9,823 \text{ m}^2 \times 10^{-3} \text{ m}^2$
 (e) $4,588 \times 10^{-5} \text{ mm}^2$ (f) 5 g/l
 (g) 15 g/l (h) $6,556 \times 10^{-2} \text{ kg/m}^3$
 (i) $2 \times 10^4 \text{ kg/m}^3$ (j) $8 \times 10^4 \text{ kg/m}^3$

CONSOLIDATED EXERCISES

1. (a) 3^5 (b) $2^5 \times 5^2 \times 3^3$
 (c) $(-2)^4$ (d) $7^2 \times x^3 \times y^2$
2. (a) 32 (b) -27 (c) 40 (d) -1
 (e) 46 (f) 1
3. (a) 1 (b) 0
 (c) 1 (d) Undefined
 (e) $3,9 \times 10^{24}$ (f) Undefined
4. (a) 3^5 (b) 2^{12} (c) 5^3 (d) 7^{11}
 (e) 7^4 (f) $2^3 \times 3^6$ (g) 1 (h) $\frac{5 \times 2}{3}$
 (i) $\frac{1}{5^{11}}$ (j) $\frac{1}{2^7 \times 3}$
5. (a) 5^9 (b) x^9 (c) x^9
 (d) $3^{4p+4} \times 2^{4p+4}$ (e) 2^6 (f) 7
 (g) y^2 (h) 2^{2p+p} (i) 2^{12}
 (j) x^{15} (k) 3^{2x-6} (l) $\frac{1}{7^6}$
 (m) $5^7 \times 3^4$ (n) 2^8 (o) x^5y^2
 (p) $3^2 \cdot 2^2 \cdot 5^2$
6. (a) x^5 (b) y^7x^2 (c) $2x^7$
 (d) $2x3y$ (e) $10xy^{4+2}x^5y^2$ (f) $\frac{12e^5}{d^3}$
 (g) b^2c^3 (h) $\frac{1}{m^4n^{10}}$ (i) 2^3d^9
 (j) $\frac{1}{m^3n^7}$ (k) 5^x (l) $3^{x-y} 2^{x-y}$
 (m) $\frac{1}{13^{13}}$ (n) $7^{a+2b} \cdot 11^{7b-13a}$
7. (a) 5^8 (b) 6^6 (c) 1 (d) -5^{15}
 (e) x^6 (f) 3^{2x-6} (g) $\frac{5^2}{7^2}$ (h) 4
 (i) 5^6 (j) $\frac{1}{16a^4}$
8. 12,31 kg
9. 0,08 grams

10. (a) 360 days (b) 32 days (c) question (a)
11. (a) 4.2435×10^8 (b) $3,689 \times 10^6$
 (c) $5,456 \times 10^{25}$ (d) 6×10^{13}
 (e) $1,206 \times 10^3$ (f) $4,297 \times 10^{-2}$
12. (a) $1,675 \times 10^{-27}$ kg (b) $1,675 \times 10^{-24}$ kg
 (c) $1,675 \times 10^{-21}$ kg
 (d) $5,97 \times 10^{23}$ neutrons
13. (a) $6,813 \times 10^5$ kg
 (b) $4,01 \times 10^7$ m; $4,01 \times 10^9$ cm; $4,01 \times 10^{10}$ m
14. (a) $8,65 \times 10^3$ kW (b) $4,65 \times 10^6$ W
 (c) $4,3 \times 10^{-9}$ pA (d) $5,5 \times 10^{-7}$ dm
 (e) 556×10^{-2} g (f) $1,28 \times 10^{-1}$ mm
 (g) $5,2 \times 10^{-11}$ TG (h) $8,8 \times 10^4$ MHz
 (i) 3,679 g (j) 0,658 kL
15. (a) 1×10^6 (b) 15 kL (c) 0,16 g/L
16. (a) 100 tiles. (b) 100 cm^2
17. (a) 63 trips. (b) $2,5 \text{ g/cm}^3$
 (c) 250 000 spades.
18. (a) 9 975 years (b) same as in (a)
 (c) 4 560 years old. (d) 7 600 years old.
19. 100 000 digits

CHAPTER 4 ALGEBRAIC EXPRESSIONS ANSWERS

EXERCISES



(b) $x \in [3; 4]$ (c) $\{x \mid 3 \leq x < 4\}$



(b) $x \in (-7; 2]$ (c) $\{x \mid -7 < x \leq 2\}$



(b) $x \in (-\infty; -9) \cup x \in (-1; \infty)$

(c) $\{x \mid x < -9 \text{ or } x > -1\}$



$\{x \mid -5 < x \leq 1\}$ $x \in [-5; 1)$



$\{x \mid -2 < x \leq 3\}$ $x \in (-2; 3]$

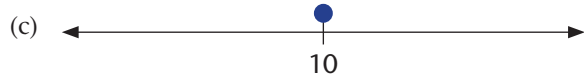

$\{t \mid t = 10\}$ $t \in [10]$

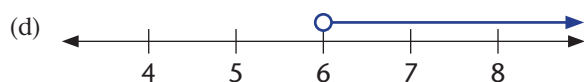

$\{s \mid s > 6\}$ $s \in (6; \infty)$

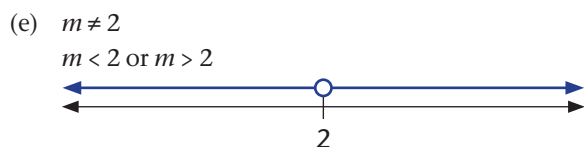

$\{m \mid m < 2 \text{ or } m > 2\}$ $m \in (-\infty; 2) \cup (2; \infty)$



$t \in (-7; 5]$



$m \in (-\infty; 2] \cup (13; \infty)$



$\{k \mid k \leq 3\}$



$\{k \mid k \leq 3 \text{ or } k > 7\}$

7. (a) (i) decreases by 10 (ii) increases by 2
(iii) 90 (iv) 30
(v) R666,67 (vi) R0,00

(b) It's correct.

8. (a) monomial (b) binomial
(c) binomial (d) trinomial
(e) monomial (f) monomial
(g) monomial (h) binomial
(i) monomial (j) monomial
(k) binomial (l) polynomial
(m) trinomial (n) binomial
(o) binomial (p) monomial

9. (a) $-m^2 + 8m + 3mn - 2n + 1$
Evaluate for $m = 2$ and $n = 3$

- (b) $14x - 7xy - 2y$
Evaluate for $x = 2$ and $y = 3$

- (c) $4x^2 - 2x$
Evaluate for $x = 2$

10. (a) (i) $8m^2n^2 + 2n - m^2 - 3m^2n$
(ii) $x^2y^2 + 5y^3 + 5x^2 + 7y$
(iii) $6r^2s^2 + 8s^3 - 10r^2 + 4s^2$
(iv) $10r^2s^3 + 5r^2s^2$
(v) $8t^2u^2 - 2n^2 + 4k^2l^2$
(vi) $2a^2b^{3c} + 2h^3$

- (b) (i) $16x^2 + 13x + 10$ (ii) $10x^2 - 6x$
(iii) $7r^2s^3 + 2t^2 + 4$ (iv) $-5p^2 + 2q^2r^3$
(v) $8x^3y - 2z^2$ (vi) $-2x^3 + x^2 - 3x + 1$

- (c) (i) $5r^2 - 21r - 7$ (ii) $10x + 3xy - 8y$
(iii) $5x^2 + 3x + 1$ (iv) $3x^2 - 7x + 1$
(v) $9m^3 - 9m^2 - m$ (vi) $-m^2$

11.

Multiply	$2x$	$-9y$
$3y$	$6xy$	$-27y^2$
$-5x$	$-10x^2$	$45xy$

- (a) $6xy$ (b) $-27y^2$
(c) $6xy - 27y^2$ (d) $-4xy + 18y^2$
(e) $6xy - 27y^2$ (f) $-2y + 18y^2$

12. (a) $2x^2 + 3x$ (b) $-2x^2 - 3x + 18$
(c) $6xy + 4x + 9y + 6$ (d) $6x^2 + 13x + 6$
(e) $2x - 3y + 5$ (f) $\frac{2x + 3}{3x + 2}$
(g) $2x - 3y + 1$

13. (a) $q^2 + 6q + 9$ (b) $9q^2 - 6q + 1$ (c) $9 - q^2$ (d) $-3q^2 - 8q + 3$
 (e) $4x^2 + 20xy + 25y^2$ (f) $4x + 10y - 4x^2 - 20xy - 25y^2$ (g) $4x^2 - 25y^2$
14. (a) $4ax + 6bx + 2cx + 2ay + 3by + cy$ (b) $2ac + ac + 4ae + 6bc + 3bd + 12be$
 (c) $3ax - 2bx + 3cx + 3ay - 2by + 3cy$ (d) $8ax - 6ay + 2az + 12bx - 9by + 3bz$
 (e) $9ax + 6bx + 9cx + 6ay + 4by + 6cy$ (f) $10dx - 6ex + 2fx + 10dy - 6ey + 2fy$
15. (a) (i) $3x + 3$ (ii) $x^2 + x$ (iii) $-ax - 3x$ (iv) $-a^2 + ab$
 (b) (i) $5x^2 + x$ (ii) $-2 - 2a + b - a^2$ (iii) $2a + 3$ (iv) $-7a^2 + 3a$
16. (a) $15x^2 \cdot 10y$ (b) $x^2 - 3x$ (c) $6x^3 + 15x^2y^3$ (d) $3m^3 + 2mn - 3m$
 (e) $12s^5 - 20s^2t + 28s^2$ (f) $a^2 + 2ab + b^2$ (g) $9a^2 + 6ab + b^2$ (h) $a^2 - 2ab + b^2$
 (i) $9a^2 - 6ab + b^2$ (j) $a^2 - b^2$ (k) $9a^2 - b^2$ (l) $ax + bx + ay + by$
17. (a) $5x^2 + 4x$ (b) $4a^2$ (c) $3b^2 + b$ (d) $7y + 3$ (e) $x^3 + 3x^2 - x - 3$

18.

	Find for each of the following expressions	$3x + 6y$	$4a^3 + 2a$	$5x + 2x$	$ax^2 - bx^3$	$12a^2b + 18ab^2$
(a)	the factors (excluding 1) of the first term;	3 and x	4 and a	5 and x	a and x	12 and a and b
(b)	the factors (excluding 1) of the second term;	2; 3 and y	2 and a	2 and x	b and x	18 and a and b
(c)	the highest common factor of the two terms;	3	$2a$	x	x^2	$6ab$
(d)	Write the expression in factor form	$3(x + 2y)$	$2a(2a^2 + 1)$	$x(5 + 2)$	$x^2(a - bx)$	$6ab(2a + 3b)$

19. (a) $(a - b)(x + 1)$ (b) $(a - b)(x - 1)$ (c) $(y + 1)(x + 1)$ (d) $(a + b)(x - 1)$
 (e) $(2x - 3)(3x + 1)$ (f) $(y - 4)(y + 3)$ (g) $(x + y)(p + q)$ (h) $(x - 3)(9x^2 + 1)$
 (i) $(a + b)(4 + 3q)$ (j) $(a + 1)(a^3 + 3)$ (k) $(x - 1)(y + 1)$ (l) $(a - b)(c - d)$

20. (a)

	If factor $m =$	If factor $n =$	$mn = 8$	$m + n = 6$	Will this work?
	+1	+8	1×8	$1 + 8$	No
	+2	+4	2×4	$2 + 4$	Yes

- (b) $(x + 2)(x + 4)$ (c) $x^2 + 6x + 8$
 (d) the product of the constants is positive and their sum is positive

21. (a)

	If factor $m =$	If factor $n =$	$mn = 6$	$m + n = -5$	Will this work?
	-1	-6	-1×-6	$-1 + -6$	No
	-2	-3	-2×-3	$-2 + -3$	Yes

- (b) $= (x - 2)(x - 3)$ (c) Expand to test
 (d) the product of the constants is positive and their sum is negative

22. (a)

	If factor $m =$	If factor $n =$	$mn = -12$	$m + n = 4$	Will this work?
	+12	-1	12×-1	$12 + (-1)$	No
	+4	-3	$4 \times (-3)$	$4 + (-3)$	No
	+6	-2	$6 \times (-2)$	$6 + (-2)$	Yes

- (b) $= (x + 6)(x - 2)$ (c) Expand to text (d) the product of the constants is negative

23. (a)

	If factor $m =$	If factor $n =$	$mn = -12$	$m + n = -4$	Will this work?
	+1	-12	1×-12	$1 + -12$	No
	+3	-4	3×-4	$3 + (-4)$	No
	+2	-6	2×-6	$2 + (-6)$	Yes





- (b) $= (x + 6)(x - 2)$ (c) Expand to test (d) the product of the constants is negative

24. (a) $(x+4)(x-3)$ (b) $(x-4)(x+3)$
 (c) $(x+6)(x+2)$ (d) $(x-6)(x-2)$
 (e) $(x+10)(x-1)$ (f) $(x-5)(x+2)$
 (g) $(x+7)(x-3)$ (h) $(x+7)(x+3)$
 (i) $(x-9)(x+2)$ (j) $(x-10)(x+2)$
 (k) $(x+1)(x+1)$ (l) $(x-1)(x-1)$
 (m) $(a+7)(a+7)$ (n) $(p-8)(p-8)$
 (o) $(m+3n)(m-n)$ (p) $(a-5b)(a-5b)$
 (q) Breadth = $x - 2y$
25. (a) $(a+7)(a+2)$ (b) $(x+6)(x-3)$
26. (a) $(a+7)(a+2)$ (b) $(x+6)(x-3)$
 (c) $(x-17)(x-1)$ (d) cannot be factorised
 (e) $(y-15)(y+2)$ (f) $(y-3)(y+10)$
 (g) $(x+5)(x-3)$ (h) $(m+7)(m-3)$
 (i) cannot be factorised (j) $(b+7)(b+8)$
 (k) cannot be factorised (l) $(a-6)(a+5)$
 (m) $(x-8)(x+3)$ (n) $(x-8)(x-5)$
27. (a) $(2a+3)(a+3)$ (b) $(3x-3)(x+2)$
29. (a) $c = 14$ (b) $b = 9$
 (c) $a = 1$
31. (a) $(5a+2)(a+5)$ (b) $(3x+4)(x-3)$
 (c) $(4x-3)(6x+1)$ (d) $(5y-2)(3y-1)$
 (e) $(2x-5)(7x+5)$ (f) $(3y-7)(4y+5)$
 (g) $(3x+2)(2x-6)$ (h) $(7m+2)(3m-3)$
 (i) $4(2x-1)(3x-2)$ (j) $2(4b-9)(3b+1)$
32. (a) $(x+3)(x-3)$ (b) $(x+4)(x-4)$
35. (a) $(3a-b)(3a+b)$ (b) $2(3a-b)(3a+b)$
 (c) $(a-1)(a+1)$ (d) $(3a^2-b^3)(3a^2+b^3)$
36. (a) $(2a-b)(2a+b)$ (b) $(m-3)(nm+3n)$
 (c) $(5x-6y)(5x+6y)$ (d) $(11x-12y)(11x+12y)$
 (e) $(4p-7q)(4p+7q)$ (f) $(8a-5bc)(8a+5bc)$
 (g) $(x-2)(x+2)$ (h) $(4x-6y)(4x+6y)$
 (i) $(1-abc)(1+abc)$ (j) $(5x^5-7y^3)(5x^5+7y^4)$
 (k) $2(x-3)(x+3)$ (l) $2(10-b)(10+b)$
 (m) $3(xy-4)(ay+4a)$ (n) $5(a^2-2b)(a^2+2b)$
38. (a) $x^3 + y^3$ (b) $x^3 - y^3$
 (c) $x^3 + 8y^3$ (d) $x^3 - 8y^3$
 (e) $8x^3 + y^3$ (f) $x^3 - 8y^3$
 (g) $27x^3 + 8y^3$ (h) $27x^3 - 8y^3$
39. (a) $(1-2x^3)(1+2x^3+4x^3)$
 (b) $(2m^3-1)(4m^6+2m^3+1)$
 (c) $(2a-b^4)(a^2+2ab+b^2)$
 (d) $(x^3-3y)(x^6+3x^3y+9y^2)$
 (e) $(5p^4-6)(25p^8+30p^4+36)$
 (f) $\left(1 + \frac{4}{t^5}\right)\left(1 - \frac{4}{t^5} + \frac{16}{t^{10}}\right)$
 (g) $(3bx-2)(x^2+2x+4)$
- (h) $(x+7)(x^2x^2-7x^3+49x^4)$
 (i) $(m+4n)(m^2-4mn+16n^2)$
 (j) $2(2a-b)(4a^2+2ab+b^2)$
 (k) $\left(\frac{10}{11} + 6y^2\right)\left(\frac{100}{121} - \frac{60y^2}{11} + 36y^4\right)$
40. (a) $2(3x+2)(x-3)$ (b) $(7m+2)(m-1)$
 (c) $2(3x-2)(2x-1)$ (d) $2x(3b+1)(4b-9)$
 (e) $6x-7y$ (f) $24a3x^2-y^2$
 (g) $(5p^4+2x^2)(25p^8-10)(p^4x^2+4x^4)$
 (h) $4ab(2a-b)(4a^2+2ab+b^2)$
 (i) $9a^2+27a+10-b^2$
 (j) $(2a-b)(4a^2+2ab+b^2) + (x-33x+4)$
 (k) $2(x-3)(x+3) + 5(a^2-2)(ba^2+2b)$
 (l) $2(2a-b)(4a^2+2ab+b^2) + (x-2)(x+2)$
 (m) $(m+4n)(m^2-4mn+16n^2) + (2y-5)(7y+5)$
 (n) $(m-3n)(m+3n) + (3y-7)(4y+5)$
41. (a) 544 (b) 1 280
42. (a)
- Input value 1
 $x^2 + 5x + 6$
 \downarrow
 $(x+3)(x+2) \div (x+2) = x+3$ (Output value)
- Input value 2
 $x+2$
 \uparrow
 $= 2+3$
 $= 5$
- (b) Addition
43. (a) $\frac{3x^2+1}{x}$ (b) $x+3$ (c) $\frac{x-2}{x+4}$
 (d) $\frac{x+3}{2}$ (e) $\frac{3x^2y^2}{2}$ (f) $\frac{a}{b}$
 (g) $\frac{2x^2(x-2)}{(x+1)}$ (h) $a-b$
44. (a) $2y-1$ (b) $\frac{x^2-y^2+2y}{y}$ (c) $\frac{a+b}{a-b}$
 (d) $\frac{r}{s}$ (e) $\frac{x+y}{x-y}$ (f) $\frac{a+2b}{a-b}$
 (g) $\frac{2x+3}{2x}$ (h) $\frac{x+1}{x+4}$
 (i) $\frac{(x+6)(x-1)}{(x+3)(x+2)}$ (j) $m+2$
 (k) $x-y$ (l) $\frac{(m-n)(m-n)}{(m+n)(m^2-mn+n^2)}$
45. (a) $\frac{11}{12}$ (b) $\frac{3}{20}$
 (c) $\frac{4a+3b}{12}$ (d) $\frac{2b+a}{ab}$
 (e) $\frac{13}{18}$ (f) $\frac{3m-2n}{3n}$
 (g) $\frac{5y-2z}{2}$ (h) $\frac{10-3xy}{5xy}$

46. (a) $\frac{a+5}{6}$ (b) $\frac{x+y}{2}$
 (c) $\frac{37a-3}{15}$ (d) $\frac{bc+ac+ab}{abc}$
 (e) $\frac{2a^2+b^2}{ab}$ (f) $\frac{3ab+b^2-a^2}{ab}$
 (g) $\frac{a-b}{6a}$ (h) $\frac{2ac+c-a}{abc}$
 (i) $\frac{6}{x^2y^2}$ (j) $\frac{-9m-4k}{18km^2}$
 (k) $\frac{20x^4+20x^3-15x^2-3x+12}{60x^5}$
 (l) $\frac{3a^2b+ab^2-4ab+b^2}{a^3b^2}$
47. (a) LCM = $x+2$ (b) LCM = $x-2$
 (c) LCM = $x-2y$ (d) LCM = $x+y$
 (e) LCM = $x+2$ (f) LCM = $a+3b$
 (g) LCM = $x+y$ (h) LCM = $a+b$
48. (a) $\frac{74}{x+y}$ (b) $\frac{4b-4a+2x^2+2xy}{4(x+y)(b-a)}$
 (c) $\frac{r^2-2rs-s^2}{s(r-s)}$ (d) $\frac{x^2-a-b}{x(a+b)}$
 (e) $\frac{2-3y}{(y-2)(a-b)}$
 (f) $\frac{(-3x-1)(9x^3-27x^2x-3)-18x^3}{9x^3-27x^2x-3}$
 (g) $\frac{6+(y+1)(y+3)}{2(y+1)}$
 (h) $\frac{2b(a+b)}{x(a+b)-y(a-b)} + \frac{x-y}{xy}$
 (i) $\frac{-1}{x+y}$
 (j) $\frac{(x-y)(y+2x)+5(x+y)}{5(x-y)}$
 (k) $\frac{y(x-1)(x-y)+9a(y-1)}{3y(y-1)}$
 (l) $\frac{2(x+y)}{(x-y)}$
49. (a) $\frac{2}{(x-5)(x+3)}$ (b) $\frac{x^2-10x+14}{(2x+3)(x-11)}$
 (c) $\frac{3x^2-23x-14}{3x-2}$ (d) $\frac{-(x^2-21x-40)}{x^2+4x-5}$
 (e) $\frac{x(y+6)}{(x+3)(x+4)}$ (f) $\frac{x^2-13x+60}{3(x-10)}$
 (g) $\frac{x^2+x+1}{(x+2)(x+1)}$ (h) $\frac{x^2+10x+13}{3(x+8)}$
 (i) $\frac{-14x^2+3xy+4y^2}{3x(5x-4y)}$ (j) $\frac{1}{x+y} + \frac{y+1}{x-1}$
 (k) $\frac{3a+x-1}{3a(x-1)}$
 (l) $\frac{3(x-y)(y-x)-a(x-1)}{a(y-x)}$
50. (a) $\frac{2}{5}$ (b) $\frac{2}{7}$
 (c) $\frac{27}{20}$ (d) $\frac{33}{5}$
51. (a) $2a$ (b) $2a$
 (c) ab (d) $\frac{d}{3}$
52. (a) x (b) $-\frac{2y^2}{x}$
 (c) $\frac{x^4}{4}$ (d) $-\frac{2}{m^2n}$
 (e) $-\frac{a^2}{3}$ (f) $\frac{m}{2n}$
 (g) $-\frac{12y}{x}$ (h) $-\frac{a^5}{7b}$
 (i) $\frac{2}{n^3}$ (j) $\frac{13x^6y^5}{2}$
 (k) $\frac{7b^2}{2}$ (l) $\frac{6}{n^4}$
53. (a) $[(x+2)-y][(x+2)+y]$
 (b) $(2x+1)(4x^2-2x+1)$
54. (a) $2(a-b)$ (b) $x+3$
55. (a) $\frac{3}{2}$ (b) $\frac{2}{5}$
 (c) $\frac{15}{(a-5)(a+5)}$ (d) $\frac{35(x+3)^2}{6(x-4)^2}$
 (e) $-\frac{4a}{3}$ (f) $\frac{b}{3a}$
 (g) $\frac{x^2-4}{x^2}$ (h) $\frac{(x-y^2)}{(x+y^2)}$
 (i) 1 (j) 1
 (k) $\frac{(a-5)(a+1)}{a(a-2)(a-4)}$ (l) $\frac{6(x^2-3x+9)}{(x^2-3x+4)}$
56. (a) $\frac{2}{5}$ (b) $\frac{2}{7}$
57. (a) $2a$ (b) $\frac{a}{2}$
58. (a) $4x^3$ (b) $-\frac{1}{2xy^2}$
 (c) $\frac{4}{9}$ (d) $-\frac{8n^5}{m^{12}}$
 (e) $\frac{a^2b^4}{-3}$ (f) $\frac{8m^5}{n^5}$
 (g) $-\frac{3}{x^5y^5}$ (h) $-\frac{25ab^5}{7}$
 (i) $\frac{m^4n^2}{2}$ (j) $24x^4y^5$
 (k) $\frac{1}{14a^6b^8}$ (l) $\frac{32}{3m^6n^4}$
59. (a) $(x-2)(x-2)$ (b) $(x-3)(x+3)$
 (c) $(a-b)(a+b)$ (d) $2(a-b)$
 (e) $x+3$

60. (a) 2 (b) $\frac{2}{5}$
 (c) $\frac{5(a+7)}{(a+5)(a-1)}$ (d) $-\frac{5}{3}$
 (e) $\frac{a(a-5)}{(a+2)}$ (f) 1
- (g) $\frac{(x^2+5a^2)(x+2)}{x^2(x-3)}$ (h) $\frac{28}{x^2(x+y)^2}$
 (i) $-\frac{x}{y(x^2-y^2)}$ (j) $\frac{1}{3}$
 (k) $\frac{(a-5)(a+1)(a-3)}{(a-2)(a-2a)(a+2a)}$ (l) $\frac{36x(x-3)}{x^2-6x+18}$

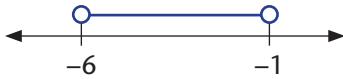
CONSOLIDATION EXERCISES

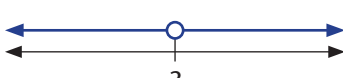
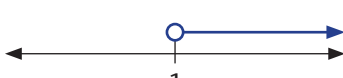
- 1 (a) (i) 
 (ii) $x \in (-5; 2]$ (iii) $\{x \mid -5 < x \leq 2\}$
- (b) (i) 
 (ii) $x \in (-4; 0]$ (iii) $\{x \mid -4 < x \leq 0\}$
- (c) (i) 
 (ii) $x \in (-6; -1)$ (iii) $\{x \mid -6 < x < -1\}$
- (d) (i) 
 (ii) $x \in (2; 8)$ (iii) $\{x \mid 2 < x < 8\}$
- (e) (i) 
 (ii) $m \in (-\infty; 3) \cup (3; \infty)$
- (f) (i) 
 (ii) $k \in (1; \infty)$ (iii) $\{k \mid k > 1\}$
2. (a) 6 (b) 13
 (c) 66 (d) -12
 (e) -24 (f) 81
3. (a) a (b) $\frac{1}{b}$
 (c) $5y$ (d) $x+1$
 (e) 6 (f) $\frac{1}{3(x+y)}$
 (g) $\frac{1}{2a}$ (h) $\left(\frac{x^3}{x+y}\right)^2$
4. (a) $\frac{8}{9}$ (b) $-\frac{12}{5}$

5. (a) 2 (b) $3+y$
 (c) a (d) 0
 (e) $\frac{3}{5z^2}$ (f) $\frac{x-3}{3}$
6. (a) $x-3$ (b) 1
 (c) $\frac{a(a-2)(a-5)}{1-a}$ (d) $\frac{(b-2)^2}{(x-2)^2}$
 (e) $\frac{1}{1+x+y}$ (f) $\frac{p^2-2pq-7q^2}{4p(p-4q)}$
7. (a) $b+1$ (b) $b+1$
8. (a) 1 (b) $\frac{3b^3}{4}$
 (c) $\frac{3x^2y}{2}$ (d) $\frac{a^2b}{3c^2}$
 (e) $\frac{ac}{b^2}$ (f) $\frac{a^2}{bc^3}$
 (g) $\frac{x^3y^2}{9}$ (h) $\frac{6}{pq}$
 (i) $\frac{b}{a^3}$ (j) $\frac{x^6y^6z}{2}$
9. (a) $\frac{a-3}{4a^3}$ (b) $\frac{3x-2y}{2(2x-3y)}$
 (c) $\frac{2(x+1)(x-1)^2}{x^2(x+2)}$ (d) $\frac{1}{y}$
10. (a) $\frac{5y-2}{xy}$ (b) $\frac{a+1}{4}$
 (c) $\frac{1}{3a}$ (d) $\frac{3}{x-3}$
 (e) $\frac{5q+p}{q}$ (f) $\frac{3y+1}{4y}$
11. (a) $(x-4)(x+4)$ (b) $(x-6)(x-2)$
 (c) $(x-3)(x+2)$ (d) $(p+3)(p-1)$
 (e) $(x+5)(x-5)$ (f) $(y-12)(y-12)$
 (g) $(a+b)(c+d)$ (h) $(x-y)(m-3)$
 (i) $(a+1)(x-1)$ (j) $(3-m)(x+2y)$
 (k) $x(x-y)(y-1)$ (l) $(1+y)(1-y-3x)$

CHAPTER 5 EQUATIONS AND INEQUALITIES ANSWERS

EXERCISES

1. (a) $x = -2$ (b) $x = -6$ (c) $x = 0$
 (d) $x = -2$ (e) $x = 27$ (f) $x = -2$
2. (a) $x = 2$ (b) $x = -2$ (c) $x = \frac{1}{4}$
 (d) $x = -\frac{1}{4}$ (e) $x = -\frac{3}{4}$ (f) $x = \frac{3}{4}$
 (g) $x = 0$ (h) $x = -3$
3. (a) $x = 1$ (b) $x = 7$ (c) $x = -1$
 (d) $x = 7$ (e) $x = 3$ (f) $x = 12$
 (g) $x = 10$ (h) $x = -2$
4. (a) $x = 11$ (b) $x = -\frac{2}{3}(x \neq -1)$
 (c) $x = -1 (x \neq 0)$ (d) $x = -\frac{11}{13}(x \neq -\frac{1}{2})$
 (e) $x = 0 (x \neq 1)$ (f) $x = -1 (x \neq -1)$
5. (a) $(\frac{35}{32}, \frac{27}{32})$ (b) $(\frac{12}{61}, -\frac{1}{61})$ (c) $(-1; 3)$
 (d) $(-1; -1)$ (e) $(\frac{1}{2}, \frac{31}{12})$ (f) $(-5; 0)$
 (g) $(28; -7)$ (h) $(-\frac{55}{7}, -\frac{129}{7})$
6. (a) $x \in \{1; 2; 3; 4; 5; 6; 7; 8; 9; 10; \dots\}$
 (b) $x \in \{-1; -2; -3; -4; -5; -6; 1; 2; 3; 4; \dots\}$
 (c) $x \in \{1; 2; 3; 4; 5; 6; 7; 8; 9; 10; \dots\}$
 (d) $x \in \{0; 2; 4; 6; 8; 10; 12; 14; 16; 18; \dots\}$
7. (a) Yes, the given set is a subset of a real numbers.
 (b) The given set is a subset of integers.

- (c) No. -10 , for example, is not a natural number.
 (d) Yes. All these numbers are whole numbers.
 (e) Yes. These are rational numbers.
8. (a) $x = 0$ (b) $x = -3$ (c) $x = 1$
9. (a) $x = 0; x = 1; x = 2; x = 3 \therefore x \in \{0; 1; 2; 3\}$
 (b) $x = 1; x = 2; x = 3 \therefore x \in \{1; 2; 3\}$
 (c) $x = -2; x = -1; x = 0; x = 1; x = 2; x = 3$
 $\therefore x \in \{-2; -1; 0; 1; 2; 3\}$
 (d) $x = -2; x = -3 \therefore x \in \{-2; -3\}$
 (e) $x = -1; x = -2; x = -3 \therefore x \in \{-1; -2; -3\}$
 (f) $x = -3 \therefore x \in \{-3\}$
10. (a) $x = -\frac{1}{2}$
 (b) $x = 0; x = 1; x = 2; x = 3 \therefore x \in \{0; 1; 2; 3\}$
11. (a) Explain (b) Explain
12. (a) $k \in \{5; 6; 7; 8\}$ (b) $k \in \{0\}$
 (c) $k \in \{-4; -3; -2; -1; 0; 1\}$
 (d) $k \in \{-4; -3; -2; -1; 0; 1; 2\}$
 (e) $k \in \{-5; -4; -3; -2; -1; 0; 1\}$
 (f) $k \in \{-5; -4; -3; -2; -1; 0; 1; 2\}$
13. (a) $\{S \in Z \mid -1 \leq S < \infty\}$ (b) $[-1; \infty)$

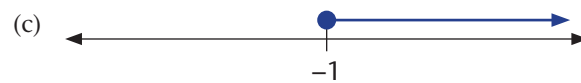

14.	Words	Interval Notation	Set Builder Notation	Number Line
	A. Set of real numbers between -3 and 4	$(-3; 4)$	$\{x \in R \mid -3 < x < 4\}$	
	Set of real numbers between -3 and including 4	$(-3; 4]$	$\{x \in R \mid -3 < x \leq 4\}$	
	Set of real numbers between -3 and 4 , both inclusive	$[-3; 4]$	$\{x \in R \mid -3 \leq x \leq 4\}$	
	Set of real numbers between -3 included and 4	$[-3; 4)$	$\{x \in R \mid -3 \leq x < 4\}$	

15. (a) $(0; 10]$ and $\{x \in \mathbb{Z} \mid 0 < x \leq 10\}$

16. a real number between 2 and 7, including both 2 and 7

17. Explain (a) to (c)

18. (a) $\{x \in \mathbb{R} \mid 2 < x \leq 7\}$ and $\{x \in \mathbb{R} \mid 2 \leq x \leq 7\}$



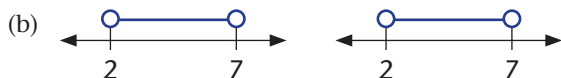

(a) $\{x \mid 2 < x < 7; x \in \mathbb{R}\}$ and $x \in \{2; 3; 4; 5; 6; 7\}$

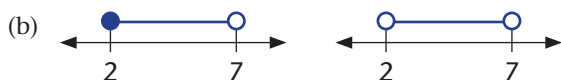

(a) $\{x \in \mathbb{R} \mid 2 \leq x < 7\}$ and $\{x \in \mathbb{R} \mid 2 < x < 7\}$



19. (a)  x is greater than 5 or less than 8

(b)  x is less than 5 or greater than 8

20. (a) $\{x \in \mathbb{R} \mid x \geq 2 \text{ and } x \leq 2\}$

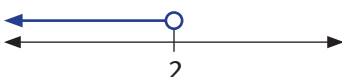

21. (a) $5x < 10$ 
 $x < 2$

(b) $-5x \leq 10$ 
 $x \leq -2$

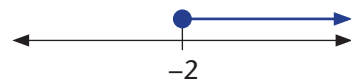
(c) $5x \geq -10$ 
 $x \geq -2$

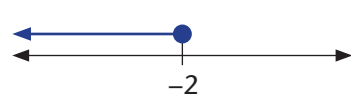
(d) $3x \leq -6$ 
 $x \leq -2$

(e) $7x > 14$ 
 $x > 2$

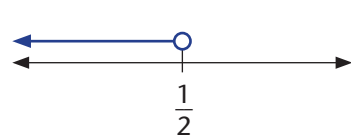
(f) $-14x < -7$ 
 $x < \frac{1}{2}$

22. (a) $x \leq 1$

(c) $x < -3$

(e) $x \leq -2$

(b) $x < 1$

(d) $x \leq -2$

(f) $x > -5$

23. (a) $x = 4$ or $x = 5$

(c) $x = 7$ or $x = 3$

(e) $x = 7$ or $x = -5$

(g) $x = 1$ or $x = -1$

(i) $x = 9$ or $x = -9$

(k) $x = 13$ or $x = -13$

(m) $x = 0$ or $x = -5$

(o) $x = 0$ or $x = 1$

(q) $x = -5$ or $x = 2$

(b) $x = -2$ or $x = -4$

(d) $x = -6$ or $x = 2$

(f) $x = -1$ or $x = -5$

(h) $x = 4$ or $x = -4$

(j) $x = 5$ or $x = -5$

(l) $x = 15$ or $x = -15$

(n) $x = 7$ or $x = -2$

(p) $x = -4$ or $x = 1$

(r) $x = 9$ or $x = -3$

24. (a) $t = \frac{v-u}{a}$

(c) $V = IR$

(e) $F = \frac{9C}{5} + 32$

(g) $R = \frac{A}{\pi} + r$

(i) $P = \frac{RQ}{Q-R}$

(k) $c = \pm \sqrt{\frac{E}{m}}$

(m) $I = \pm \sqrt{\frac{P}{R}}$

(b) $a = \frac{v-u}{t}$

(d) $R = \frac{V}{I}$

(f) $r = \pm \sqrt{\frac{A}{\pi}}$

(h) $Q = \frac{RP}{P-R}$

(j) $m = \frac{c^2}{E}$

(l) $R = \frac{P}{I^2}$

25. Perimeter rectangle = Perimeter triangle

$$4x + 10 = 10x + 4$$

$$-6x = -6$$

$$x = 1$$

26. \therefore The numbers are 14; 15; and 16 respectively.

27. \therefore Adult tickets cost R20 each.

28. 6 and 18

29. 63 adult tickets and 37 children tickets

30. 6 essay type questions and 15 multiple choice questions

31. Dimensions of fowl run are 2 meters by 3 meters





32. Consecutive numbers are -6 & -7

33. (a) 21 tonnes of refined chrome & 43 tonnes of refined vanadium

(b) 7 batch A & 6 batch B

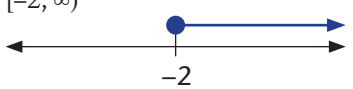
34. Ends will touch at temperature $26,92^\circ\text{C}$

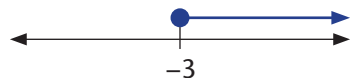
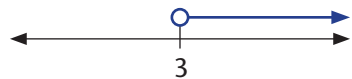
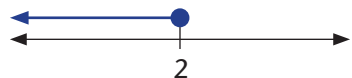
CONSOLIDATION EXERCISES

1. (a) $x = -6$ (b) $x = 13$
 (c) $x = \frac{7}{2}$ (d) $x = \frac{7}{3}$
 (e) $x = \frac{3}{4}$ (f) $x = 18$
 (g) $x = 0$ (h) $x = -\frac{1}{2}$
2. (a) $x = \frac{3}{5}$ (b) $x = \frac{17}{3}$
 (c) $x = -\frac{12}{7}$ (d) $x = -\frac{3}{2}$
 (e) $x = \frac{18}{7}$ (f) $x = -\frac{10}{3}$
 (g) $x = -\frac{90}{13}$ (h) $x = -1$ & $x = -2,5$
3. (a) $x = 16$ (b) $x = -13$
 (c) $x = -3$ (d) $x = \frac{14}{25}$
 (e) $x = -13$ (f) $x = -\frac{1}{3}$
4. (a) $(1; \frac{3}{2})$ (b) $(-2; -2)$
 (c) $(-\frac{1}{34}; -\frac{27}{17})$ (d) $(\frac{28}{31}; \frac{41}{62})$
 (e) $(\frac{490}{143}; \frac{15}{286})$
5. (a) $k \in \{7\}$ (b) $k \in \{-1; 0; 1; 2; 3\}$
 (c) $k \in \{-4; -3; -2; -1; 0\}$ (d) $k \in \{0; 1; 2; 3; 4; 5\}$
 (e) $k \in \{2; 3\}$ (f) $k \in \{-3; -2; -1; 0; 1\}$
6. (a) $\{M \in Z \mid -2 \leq M < \infty\}$
 (b) $[-2; \infty)$
 (c) 
7. (0; 10]
8. (a) $x < 2$ 
 (b) $x \geq -3$ 
 (c) $x > 3$ 
 (d) $x \leq -2$ 
 (e) $x > 3$ 

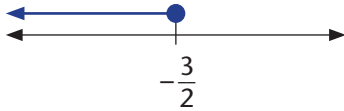
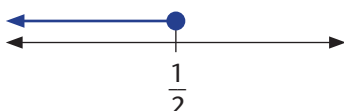
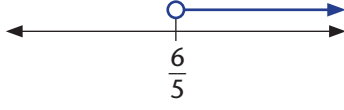
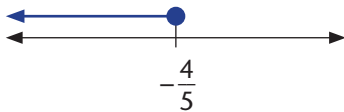
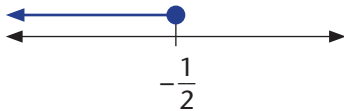
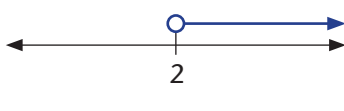
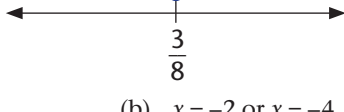
- (f) $-\frac{3}{2} \geq x$ 
- (g) $x \leq \frac{1}{2}$ 
- (h) $x > \frac{6}{5}$ 
- (i) $x \leq -\frac{4}{5}$ 
- (j) $x \leq -\frac{1}{2}$ 
- (k) $x > 2$ 
- (l) $x > \frac{3}{8}$ 
9. (a) $x = 3$ or $x = 4$ (b) $x = -2$ or $x = -4$
 (c) $x = 3$ or $x = -3$ (d) $x = 6$ or $x = -2$
 (e) $x = 0$ or $x = 7$ (f) $x = 0$ or $x = -7$
 (g) $x = 0$ or $x = 1$ (h) $x = -5$ or $x = -1$
 (i) No solution
10. (a) $a = \frac{v-u}{t}$ (b) $t = \frac{v-u}{a}$
 (c) $R = \frac{V}{I}$ (d) $v = IR$
 (e) $Q = \frac{RP}{P-R}$ (f) $r = \pm \sqrt{\frac{A}{\pi}}$
 (g) $I = \pm \sqrt{\frac{P}{R}}$ (h) $\frac{E}{c^2} = m$
 (i) $r = R - \frac{A}{\pi}$

CHAPTER 6 TRIGONOMETRY ANSWERS

EXERCISES

- they are the same
 - the three values for the three different ratios are the same
- the same ratio in each of your three triangles should have the same value
- $26^\circ; 4,9:10; 0,49$ (b) $45,6^\circ; 10,2:10; 1,0$
 - $14,7^\circ; 2,6:10; 0,26$
 - $14,3^\circ; 2,5:10; 0,25; 27,3^\circ; 5,2:10; 0,52$
 - $26^\circ; 4,9:10; 0,49; 50,6^\circ; 12,2:10; 1,2; 0^\circ; 0:10; 0$
 - undefined
- $36,9^\circ$ (b) $39,7^\circ$ (c) $16,7^\circ$
 - $81,25^\circ$ (e) $0,42$ (f) $0,04$
- $1,5 \text{ mm}; 1,2 \text{ mm}$
 - $5,5 \text{ cm}; 0,6$
 - $45^\circ; 45^\circ; 1,4 \text{ units}$
 - $4,7 \text{ units}; 12,8 \text{ units}$
 - $26,6^\circ; 63,4^\circ; 2,2 \text{ units}$
 - $2,7 \text{ units}; 3,3 \text{ units}; 38,6^\circ$
- $d = \text{opposite}$ $e = \text{adjacent}$ $f = \text{hypotenuse}$
 - $ST = \text{opposite}$ $RS = \text{adjacent}$ $RT = \text{hypotenuse}$
 - $m = \text{opposite}$ $l = \text{adjacent}$ $n = \text{hypotenuse}$
 - $y = \text{opposite}$ $x = \text{adjacent}$ $r = \text{hypotenuse}$
- $BC \approx 40 \text{ cm}$
 - $AC \approx 19 \text{ cm}$
 - $BC = \text{opposite}$ $AB = \text{adjacent}$ $AC = \text{hypotenuse}$
 - 54°
 - $AB = \text{opposite}$ $BC = \text{adjacent}$ $AC = \text{hypotenuse}$
- All four statements are correct. Use this exercise to clarify the minimum amount of information needed to construct a particular right-angled triangle versus the minimum amount needed to construct a right angle with certain ratios of sides (i.e. one of infinitely many similar triangles, all with the same ratios of sides).
 - $\frac{3}{5}$ or $0,6$ (b) $\frac{4}{5}$ or $0,8$
 - $\frac{12}{13}$ or $0,923$ (d) $\frac{5}{13}$ or $0,385$
 - $\frac{1}{2}$ or $0,5$ (f) $\frac{2}{1}$ or 2
 - $\frac{r}{p}$ (h) $\frac{4}{5}$ or $0,8$
 - $\frac{12}{5}$ or $2,4$ (j) $0,89$
 - $\frac{4}{5}$ or $0,8$ (l) $\frac{r}{q}$
 - $0,45$ (n) $\frac{q}{r}$
 - α (p) 20°
 - $90^\circ - \alpha$ (r) θ
 - β (t) $90^\circ - \alpha$
 - $90^\circ - \alpha$ (v) $90^\circ - \beta$
 - β
- $\sin \theta = 0,6; \cos \theta = 0,8; \tan \theta = 0,75$
 - $\sin \alpha = 0,64; \cos \alpha = 0,77; \tan \alpha = 0,83$
 - $\sin \theta = 0,29; \cos \theta = 0,96; \tan \theta = 0,3$
 - $\sin \alpha = 0,99; \cos \alpha = 0,15; \tan \alpha = 6,5$
 - $\sin 23^\circ = 0,39; \cos 23^\circ = 0,92; \tan 23^\circ = 0,42$
 - $\sin 46^\circ = 0,72; \cos 46^\circ = 0,69; \tan 46^\circ = 1,04$
- $\frac{4}{3}$ or $1,33$ (b) $\frac{5}{4}$ or $1,25$
 - $\frac{13}{12}$ or $1,083$ (d) $\frac{13}{5}$ or $2,6$
 - 2 (f) $\frac{3}{4}$ or $0,75$
 - $\frac{p}{q}$ (h) $\frac{5}{3}$ or $1,67$
 - $\frac{5}{12}$ or $0,417$ (j) $1,12$
 - $2,24$ (l) $\frac{q}{r}$
 - $\frac{p}{r}$ (n) $\frac{r}{q}$
- $3,73$ (b) $1,40$ (c) $0,38$
 - $0,35$ (e) $0,86$ (f) $1,93$
 - 0 (h) 0 (i) 0
 - $0,05$ (l) $1,45$ (m) $1,59$
 - $1,59$ (o) $50,4$ (p) $-0,11$
- 1 (b) $2,11$ (c) $57,30$
 - $4,26$ (e) $2,48$ (f) 1
 - $4,46$ (h) 1 (i) $2,86$
 - $0,04$ (k) $-0,03$
- $74,05$ (b) $30,39$ (c) undefined
 - $75,52^\circ$ (e) $60,97^\circ$ (f) $36,12^\circ$
 - $0,21$
- 0° (b) 0 (c) 90°
 - the run is always zero, so the quotient of rise/run is undefined.
- $B(9,3); C(16; 8,6)$
 - (i) $0,54$ (ii) $0,54$ (iii) $0,54$
 - 28°
- $0,54$ (b) $0,5418$
- $A: x = 1; \cos 0^\circ = \frac{1}{1} = 1$
 $D: x = 0; \cos 270^\circ = \frac{0}{1} = 0$
 - $A: x = 0; \sin 0^\circ = \frac{0}{1} = 0$
 $D: x = -1; \sin 270^\circ = \frac{(-1)}{1} = -1$

- (c) increases from 0 to 1; decreases from 1, to 0 and then to -1; increases from -1 back to zero
24. (a) -0,84 (b) -3,37
 (c) -5,67 (d) 57,29
 (e) 0,02 (f) -0,02
 (g) 0,02 (h) -0,02
 (i) 1 (j) -1
 (k) 1 (l) -1
25. (a) (1,87; 0) (b) (-100; 0)
 (c) (-5; -5) (d) (-0,3; 0,3)
26. (a) B(0;7,23); C(-7,23;0)
 (b) $\tan 180^\circ = \frac{0}{(-7,23)} = 0$; $\tan 90^\circ = \frac{7,23}{0}$ which is undefined
 (c) the ratios involving x , y and r remain the same for different radii, or said in another way, all circles are similar
27. (b) angle for D = 315°
 (c) $\tan 315^\circ = \frac{(-5)}{5} = -1$ (d) 7,07 units
28. (a) $146,69^\circ$ (b) -25
 (c) -0,23 (d) $15,15^\circ$
 (e) $7,13^\circ$ (f) -0,11
29. (a) -2,25 (b) $323,13^\circ$
 (c) 1,25 units
30. (a) M(100;0); P(100;140); Q(50;70); R(0;70); S(50;0)
 (b) M: $34,99^\circ$; R: $55,01^\circ$; S: 90°
 (c) $35,54^\circ$ and $86,02\text{m}$
 (d) $54,46^\circ$ and $172,05\text{m}$
31. (a) $\sin \theta = \frac{\sqrt[3]{10}}{10}$ $\cos \theta = \frac{\sqrt{10}}{10}$ $\tan \theta = -3$
 $\operatorname{cosec} \theta = \frac{\sqrt{10}}{3}$ $\sec \theta = \sqrt{10}$ $\cot \theta = \frac{4}{3}$
 (b) $\sin \theta = \frac{3}{4}$ $\cos \theta = \frac{3}{4}$ $\tan \theta = \frac{3}{4}$
 $\operatorname{cosec} \theta = \frac{5}{3}$ $\sec \theta = \frac{5}{4}$ $\cot \theta = \frac{4}{3}$
 (c) $\sin \theta = \frac{\sqrt[3]{17}}{17}$ $\cos \theta = \frac{\sqrt{11}}{11}$ $\tan \theta = -4$
 $\operatorname{cosec} \theta = \frac{\sqrt{17}}{4}$ $\sec \theta = \sqrt{11}$ $\cot \theta = \frac{1}{-4}$
 (d) $\sin \theta = \frac{-\sqrt[3]{10}}{10}$ $\cos \theta = \frac{\sqrt{10}}{10}$ $\tan \theta = 3$
 $\operatorname{cosec} \theta = \frac{\sqrt{10}}{-3}$ $\sec \theta = \sqrt{10}$ $\cot \theta = \frac{1}{3}$
 (e) $\sin \theta = \frac{178}{255}$ $\cos \theta = \frac{548}{765}$ $\tan \theta = \frac{267}{274}$
 $\operatorname{cosec} \theta = \frac{255}{178}$ $\sec \theta = \frac{765}{548}$ $\cot \theta = \frac{274}{267}$
 (f) $\sin \theta = \frac{-\sqrt[3]{26}}{15}$ $\cos \theta = \frac{1,1}{1,5}$ $\tan \theta = \frac{-\sqrt[3]{26}}{11}$
 $\operatorname{cosec} \theta = \frac{15}{-\sqrt[3]{26}}$ $\sec \theta = \frac{1,5}{1,1}$ $\cot \theta = \frac{11}{-\sqrt[3]{26}}$
 (g) $\sin \theta = \frac{-12}{13}$ $\cos \theta = \frac{-5}{13}$ $\tan \theta = \frac{12}{5}$
 $\operatorname{cosec} \theta = \frac{-13}{12}$ $\sec \theta = \frac{-13}{5}$ $\cot \theta = \frac{5}{12}$

- (h) $\sin \theta = \frac{3}{7}$ $\sec \theta = \frac{\sqrt[3]{10}}{7}$ $\tan \theta = \frac{\sqrt[3]{10}}{20}$
 $\operatorname{cosec} \theta = \frac{7}{3}$ $\sec \theta = \frac{7}{\sqrt[3]{10}}$ $\cot \theta = \frac{20}{\sqrt[3]{10}}$
32. (a) 1,00 (b) -0,63 (c) 0,50
 (d) 0,50 (e) -0,50 (f) 0,87
 (g) -0,050 (h) -0,77 (i) 0,03
 (j) -0,03 (k) -0,06 (l) 0,03
33.

	45°	135°	225°	315°
sin α	$\frac{\sqrt{2}}{2}$	$\frac{\sqrt{2}}{2}$	$\frac{\sqrt{2}}{2}$	$\frac{\sqrt{2}}{2}$
cos α	$\frac{\sqrt{2}}{2}$	$\frac{\sqrt{2}}{2}$	$\frac{\sqrt{2}}{2}$	$\frac{\sqrt{2}}{2}$
34. 45° ; 225°
35. (a) $53,1^\circ$ (b) -6 units
 (c) 0,37 unit (d) $63,4^\circ$
 (e) 0,69 units (f) 34,6 units
 (g) $e = 8,19$; $f = -5,74$ (h) 60 units
 (i) 1,28 units (j) $e = 3$; $m = 4$
36. (a) $\sin \alpha = -0,71$ $\cos \alpha = -0,70$ $\tan \alpha = 1,02$
 (b) $\cos \beta = -1$; $\cot \beta$ is undefined
 (c) $\operatorname{cosec} \theta = \frac{\sqrt{29}}{5}$ $\sec \theta = \frac{\sqrt{29}}{-2}$ $\cot \theta = \frac{-2}{5}$
 (d) $\sin \theta = \frac{-12}{13}$ $\cot \theta = \frac{5}{-12}$
 (e) $\frac{\sqrt{5}}{5}$
 (f) $\sin A = 0,98$ $\cos A = 0,17$
 $2 \sin A - \cos A = 1,79$ $3 \cot A \times \sin A = 0,52$
 (g) $\tan \beta = \frac{4}{-3}$ $\frac{\sin \beta}{\cos \beta} = \frac{4}{-3}$ $\sin \beta \times \cos \beta = \frac{-12}{25}$
 $\frac{1}{1 + \operatorname{cosec} \beta} = \frac{4}{9}$
 (h) $\sin \theta = \frac{\sqrt{2}}{2}$ $\cos \theta = \frac{\sqrt{2}}{2}$ $\frac{\sec \theta}{\operatorname{cosec} \theta} = 1$
37. (a) 0° (b) $11,5^\circ$
 (c) $23,6^\circ$ (d) $53,1^\circ$
 (e) 90° (f) Impossible
 (g) 90° (h) 60°
 (i) 0° (j) Impossible
 (k) 0° (l) $18,4^\circ$
 (m) $33,7^\circ$ (n) 45°
 (o) $53,1^\circ$
38. (a) $82,4^\circ$ (b) $62,4^\circ$ (c) 30°
 (d) 45° (e) $112,4^\circ$ (f) $18,4^\circ$
 (g) $23,6^\circ$ (h) $15,9^\circ$ (i) -3,12
 (j) $36,8^\circ$ (k) $16,8^\circ$ (l) -2,3
 (m) $33,7^\circ$ (n) $3,9^\circ$ (o) 2
 (p) $55,1^\circ$ (q) (i), (l) and (o)
39. (a) they are equal; corresponding angles are equal (equivalently, the two triangles are similar)
 (b) 63m; no (c) $83,7^\circ$; yes

40. (a) 0,32 (b) 18°
41. (a) 19
 (b) 337; the sun is 337 times further from the earth than the moon
 (c) very big! Saying the sun is 19 times further from the earth than the moon is a very big error compared to saying it is 337 times further than the moon.
 (d) 129 million km
42. (a) $50 \operatorname{cosec} 280 = 107$, so yes (b) 94 m

43.

Chamfer angle	Value of d
60°	4,3 mm
90°	2,5 mm
110°	1,8 mm

44. (a) $AC = 3,05\text{m}$; $BC = 1,75\text{m}$ (b) no
 (c) 1,65 m if truss plates are used to connect the trusses (longer if a mortise and tenon or some other joint is used)
45. (b) $11,5^\circ$
46. (b) 26 cm
 (c) **Hint:** Is the sun always at the same elevation?

47. (a)

Input ($^\circ$)	Output
0	0
15	0,258 8
30	0,5
45	0,707 1
60	0,866
75	0,965 9
90	1
105	0,965 9
120	0,866
135	0,707 1
150	0,5
165	0,258 8
180	0
195	-0,258 8
210	-0,5
225	-0,707 1
240	-0,866
255	-0,965 9
270	-1
285	-0,965 9
300	-0,866
315	-0,707 1
330	-0,5
345	-0,258 8
360	0

50. (a) $(41^\circ; 1,31)$
 (b) (i) $(41^\circ; 0,16)$
 (c) $(41^\circ; -0,66)$
 (d)

θ	f $y = \sin \theta$	g $y = 2 \sin \theta$	h $y = \frac{1}{4} \sin \theta$	k $y = -\sin \theta$
41°	0,66	1,31	0,33	-0,33
90°	1	2	0,5	-0,5
180°	0	0	0	0
203°	-0,39	-0,78	-0,20	0,20

51. $f(x) = 2 \sin x$; $k(x) = -\sin x$

52.

Input ($^\circ$)	Output
0°	0.00
15°	0.27
30°	0.58
45°	1.00
60°	1.73
75°	3.73
90°	undefined
105°	-3.73
120°	-1.73
135°	-1.00
150°	-0.58
165°	-0.27
180°	0.00
195°	0.27
210°	0.58
225°	1.00
240°	1.73
255°	3.73
270°	undefined
285°	-3.73
300°	-1.73
315°	-1.00
330°	-0.58
345°	-0.27
360°	0.00

54. (a) $78,69^\circ; 84,29^\circ; 87,14^\circ; 88,57^\circ$
 (b) $114,59^\circ \quad -114,59^\circ \quad 114,59^\circ \quad -114,59^\circ$
 (d) 143,24 190,98 286,48 572,96
56. (a) $a > 1$ (and also when a less than -1)
 (b) $0 < a < 1$ (and also when a is between -1 and 0)
 (c) $a < 0$

57.

x	$f(x) = \cos x$	$g(x) = -\cos x$
0°	1.00	-1.00
45°	0.71	-0.71
90°	0.00	0.00
135°	-0.71	0.71
180°	-1.00	1.00
225°	-0.71	0.71
270°	0.00	0.00
315°	0.71	-0.71
360°	1.00	-1.00

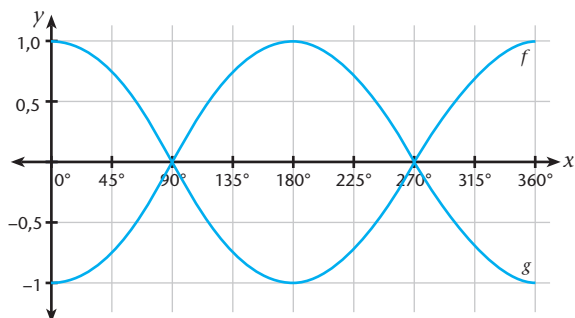

- (a) $(90^\circ; 0)$; $(270^\circ; 0)$ for both f and g
- (b) f : $(0^\circ; 1)$; $(180^\circ; -1)$; $(360^\circ; 1)$
 g : $(0^\circ; -1)$; $(180^\circ; 1)$; $(360^\circ; -1)$
- (c) 1; yes, the amplitudes are both 1
- (d) $x \in \{0^\circ; 180^\circ; 360^\circ\}$
- (e) $(90^\circ; 0)$ and $(270^\circ; 0)$
- (f) Domain of $g = \{x \mid 0^\circ \leq x < 360^\circ\}$;
 Range of $g = \{y \mid -1 < y \leq 1\}$

58. (a)

θ	$u(\theta) = 0,4 \tan \theta$	$v(\theta) = 1,2 \tan \theta$
0°	0.00	0.00
30°	0.23	0.69
60°	0.69	2.08
90°	undef.	undef.
120°	-0.69	-2.08
150°	-0.23	-0.69
180°	0.00	0.00
210°	0.23	0.69
240°	0.69	2.08
270°	undef.	undef.
300°	-0.69	-2.08
330°	-0.23	-0.69
360°	0.00	0.00

- (b) (i) contraction; $\frac{1}{3}$
- (ii) dilation; 3
- (ii) horizontal intercepts

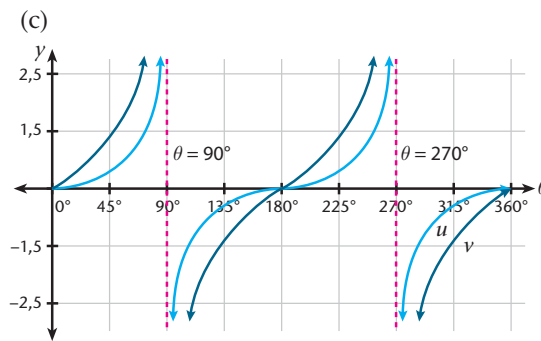

59. (a) $\alpha = 5$ (amplitude); $\beta = 90$ (so that $90 \times 4 = 360$)
 (b) Treat βt as a single variable and make $x = \beta t$;
 draw up a table for inputs of x and outputs of $5 \cos x$; label your horizontal axis $x = \beta t$, and your vertical axis $y = 5 \cos x$

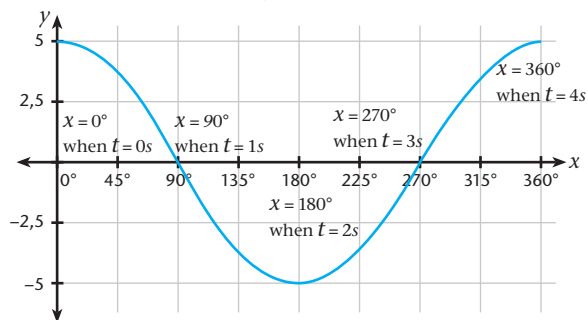

60. (a) $(2,30; 5,54)$ (b) 4,60

(c)

θ	$h(\theta) = 6 \cos \theta$	$H(\theta) = 12 \cos \theta$
0°	6,00	12,00
90°	0,00	0,00
180°	-6,00	-12,00
270°	0,00	0,00
360°	6,00	12,00

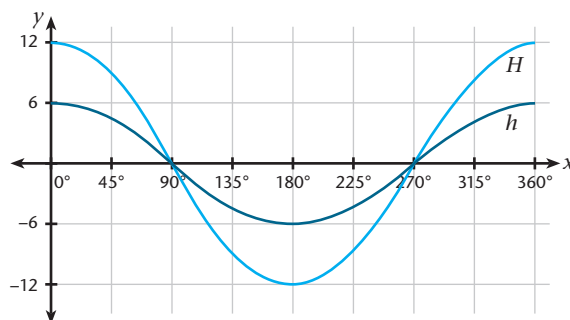

- (d) It tells us how far to the left or to the right a point on the wheel circumference is from the vertical line going through the centre of the wheel

- (e) H is h dilated by a factor of 2 (in another way, h is H contracted by a factor of 0,5)

61. (b)

θ	$y = \sin \theta$	$y = \sin \theta + 2$
0	0.00	2.00
45	0.71	2.71
90	1.00	3.00
135	0.71	2.71
180	0.00	2.00
225	-0.71	1.29
270	-1.00	1.00
315	-0.71	1.29
360	0.00	2.00

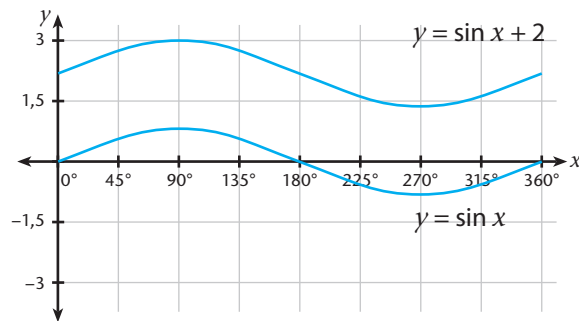

62.

θ	$f(x) = \sin x - 1$	$g(x) = f(x) + 0,5$
0	-1.00	-0.50
30	-0.50	0.00
60	-0.13	0.37
90	0.00	0.50
120	-0.13	0.37
150	-0.50	0.00
180	-1.00	-0.50

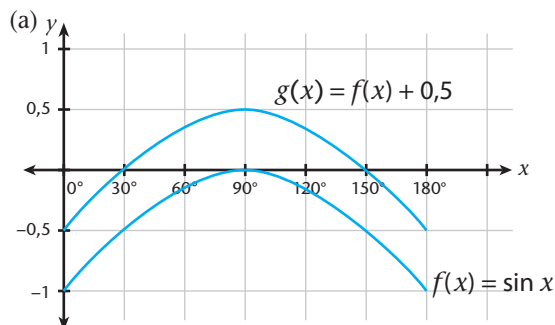

- (b) Range of $f = \{y \mid -1 < y <= 0\}$
 (c) x -intercept: $(90^\circ; 0)$; y -intercept: $(0^\circ; -1)$
 (d) $g(x) = \sin x - 0,5$
 (e) Range of $g = \{y \mid -0,5 < y <= 0,5\}$
 (f) 30° and 150°

63. $V(\theta) = v(\theta) + 11,5$

θ	Height of connecting axle above/below main axle: $v(\theta) = 10 \sin \theta$	Height of cradle floor above ground in metres
0	0.0	11.5
45	7.1	18.6
90	10.0	21.5
135	7.1	18.6
180	0.0	11.5
225	-7.1	4.4
270	-10.0	1.5
315	-7.1	4.4
360	0.0	11.5

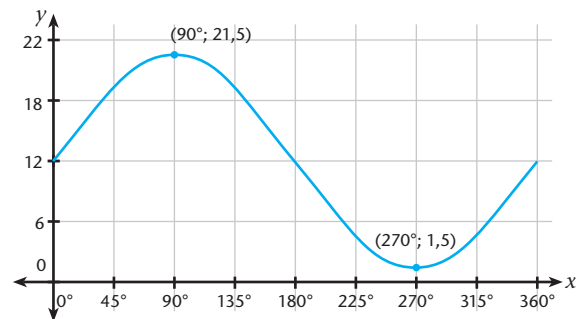

65. (a) 1,7 V
 (b) approximating by reading directly from the graph: $35^\circ, 145^\circ, 215^\circ$ and 325° ; solving the equations $1,7 \sin x = 1$ and $1,7 \sin x = -1$ gives more accurate solutions: 36° and 144° for the first equation and 216° and 324° for the second equation
 (c) reading directly from the graph, approximately when $60^\circ < x <= 120^\circ$ and $240^\circ < x <= 300^\circ$; solving the equations $1,7 \sin x = 1,5$ and $1,7 \sin x = -1,5$ will give you more accurate values for the four interval boundaries (e.g. the lower boundary of the first interval is actually $61,9^\circ$ and not 60°)
 (d) $V(x) = 1,7 \sin x$
 (e) 0 s; 0,1 s; 0,2 s
 (f) 0,5 s; 1,5 s
 (g) using the approximate readings: $0,033 < t <= 0,067$ and $0,133 < t <= 0,167$

66. (a) Domain = $\{\theta \mid 0^\circ < \theta < 90^\circ\}$; Range = $\{l \mid 0 < l < \infty\}$
 (b) No, because lead angles too close to 0° mean many turns are needed for even a small lead, while lead angles that are close to 90° mean a small fraction of a turn will cause a very big lead; it is also very difficult to thread bolts with a very small lead angle; friction may make turning bolts with very small or very large lead angles difficult
- (c) use your ruler to make accurate readings:
 1,6 mm; 7,3 mm; 18,8 mm
 (d) $3,1^\circ$; $11,7^\circ$; $37,7^\circ$
 (e) $l(\theta) = 19,1 \tan \theta$
 (f) 3,03 mm

CONSOLIDATION EXERCISE

1. (a) $\frac{4}{3}$ (b) $-\frac{3}{5}$ (c) $-\frac{4}{5}$ (d) $-\frac{5}{4}$
 2. $\frac{2}{3}$
 3. 70,02 m
 4. 138,56 m
 5. (a) $\theta = 15,04^\circ$ or $\theta = 105,04^\circ$ (b) $\theta = 65,4^\circ$ or $\theta = 245,4^\circ$
 6. (a) $y = \sin x$ (b) $y = -2 \cos x$
 7. (c) 36
 8. (a) $\frac{h}{d}$ (b) $\frac{h}{d+35}$ (c) 52,41 m (d) 71,66
 9. (a) 0,46 (b) 0,89
 (c) 1,33
 10. $27,76^\circ$
 11. $\frac{24}{7}$
 12. (a)

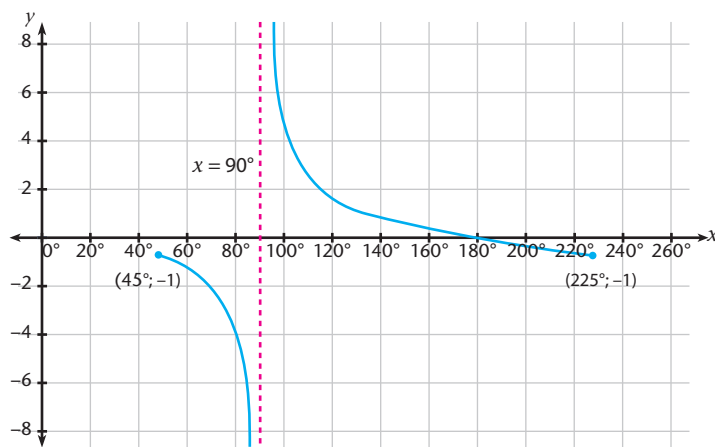

- (b) there is no maximum y -value
13. (a) 655 m
 (b) $46,4^\circ$

CHAPTER 7 FUNCTIONS AND GRAPHS ANSWERS

EXERCISES

1.

x	-5	-4	-3	-2	-1	0	1	2	3	4	5	6
f(x)	5	4	3	2	1	0	-1	-2	-3	-4	-5	-6
g(x)	0	1	2	3	4	5	6	7	8	9	10	11
h(x)	4	3	2	1	0	-1	-2	-3	-4	-5	-6	-7

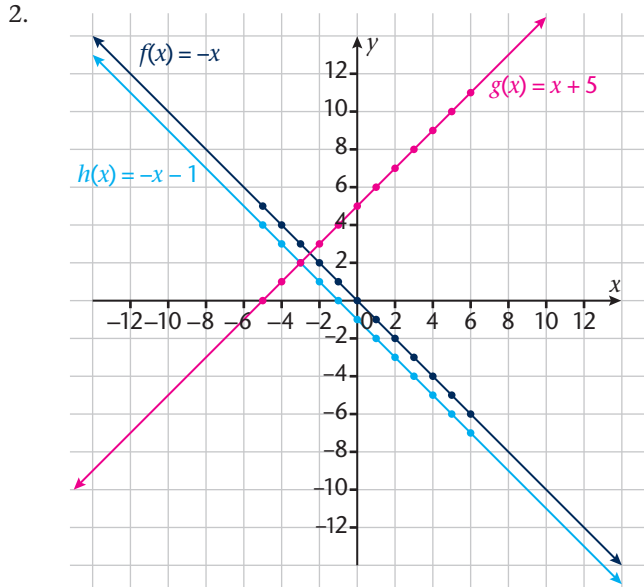

3.

Function	x-intercept	y-intercept	Domain	Range
$f(x) = -x$	(0; 0)	(0; 0)	$x \in \mathbb{R}$	$y \in \mathbb{R}$
$g(x) = x + 5$	(-5; 0)	(0; 5)	$x \in \mathbb{R}$	$y \in \mathbb{R}$
$h(x) = -x - 1$	(-1; 0)	(0; -1)	$x \in \mathbb{R}$	$y \in \mathbb{R}$

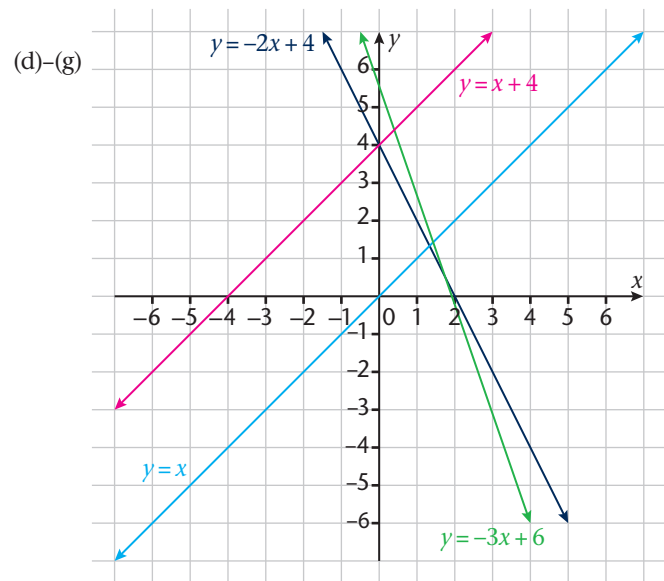
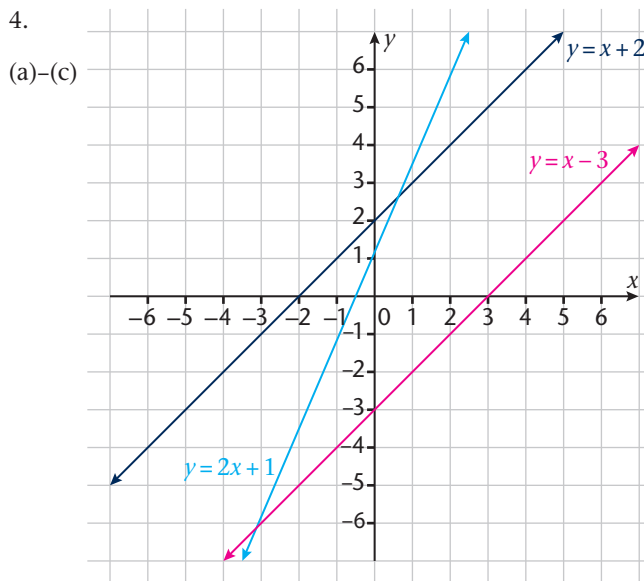

5. (reading of values to be done as accurate as possible)

x	-2	-1	0	1	2	3	4
y = g(x)	7	5,25	3,5	1,75	0	-1,75	-3,5

6. (a)

x	-4	-3	-2	-1	0	1	2	3	4
f(x)	16	9	4	1	0	1	4	9	16
g(x)	-16	-9	-4	-1	0	-1	-4	-9	-16

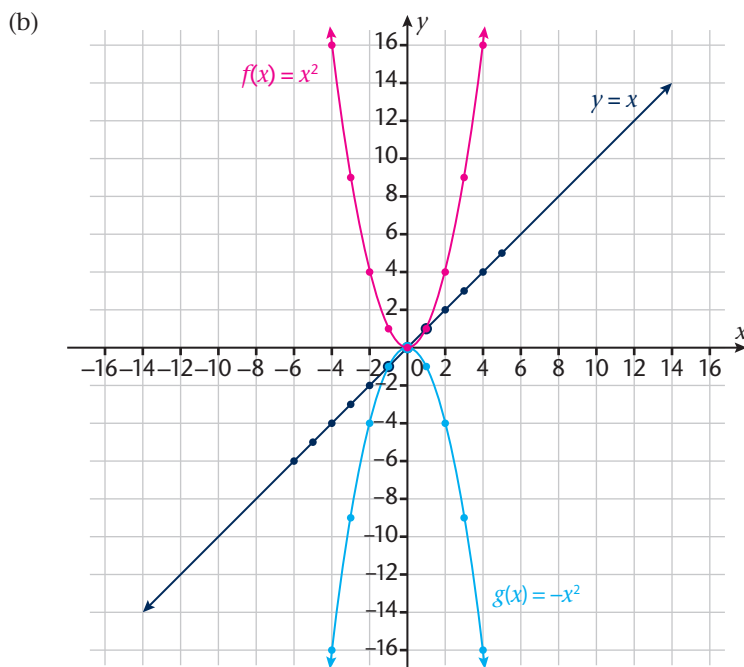

(c)

Function	x-intercepts	y-intercept	Axis of symmetry	Turning point	Domain	Range	Shape
f(x)	(0; 0)	(0; 0)	$x = 0$	(0; 0)	$x \in \mathbb{R}$	$y \geq 0$	
g(x)	(0; 0)	(0; 0)	$x = 0$	(0; 0)	$x \in \mathbb{R}$	$y \leq 0$	

7.

Function	x-intercept	y-intercept	Turning point	Domain	Range	Axis of symmetry
(a) $f(x) = x^2 + 2$	None	(0; 2)	(0; 2)	$x \in \mathbb{R}$	$y \geq 2$	$x = 0$
(b) $f(x) = x^2 + 12$	None	(0; 12)	(0; 12)	$x \in \mathbb{R}$	$y \geq 12$	$x = 0$
(c) $f(x) = x^2 + 21$	None	(0; 21)	(0; 21)	$x \in \mathbb{R}$	$y \geq 21$	$x = 0$
(d) $f(x) = x^2 + 100$	None	(0; 100)	(0; 100)	$x \in \mathbb{R}$	$y \geq 100$	$x = 0$
(e) $f(x) = x^2 + 121$	None	(0; 121)	(0; 121)	$x \in \mathbb{R}$	$y \geq 121$	$x = 0$

8.

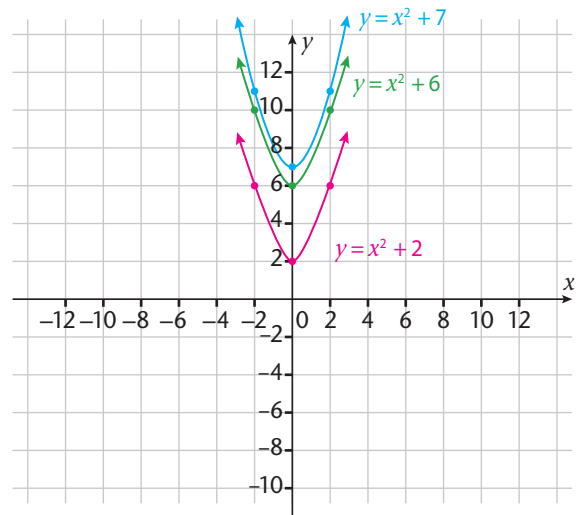
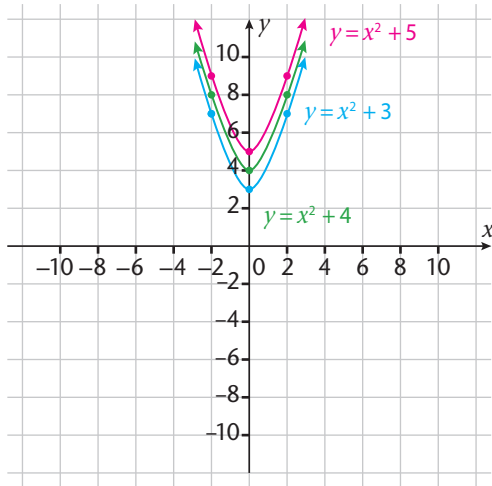

9.

Function	x-intercept	y-intercept	Turning point	Domain	Range	Axis of symmetry
(a) $f(x) = x^2 + 5$	None	(0; 5)	(0; 5)	$x \in \mathbb{R}$	$y \geq 5$	$x = 0$
(b) $f(x) = x^2 + 6$	None	(0; 6)	(0; 6)	$x \in \mathbb{R}$	$y \geq 6$	$x = 0$
(c) $f(x) = x^2 + 3$	None	(0; 3)	(0; 3)	$x \in \mathbb{R}$	$y \geq 3$	$x = 0$
(d) $f(x) = x^2 + 4$	None	(0; 4)	(0; 4)	$x \in \mathbb{R}$	$y \geq 4$	$x = 0$
(e) $f(x) = x^2 + 7$	None	(0; 7)	(0; 7)	$x \in \mathbb{R}$	$y \geq 7$	$x = 0$
(f) $f(x) = x^2 + 10$	None	(0; 10)	(0; 10)	$x \in \mathbb{R}$	$y \geq 10$	$x = 0$

10.

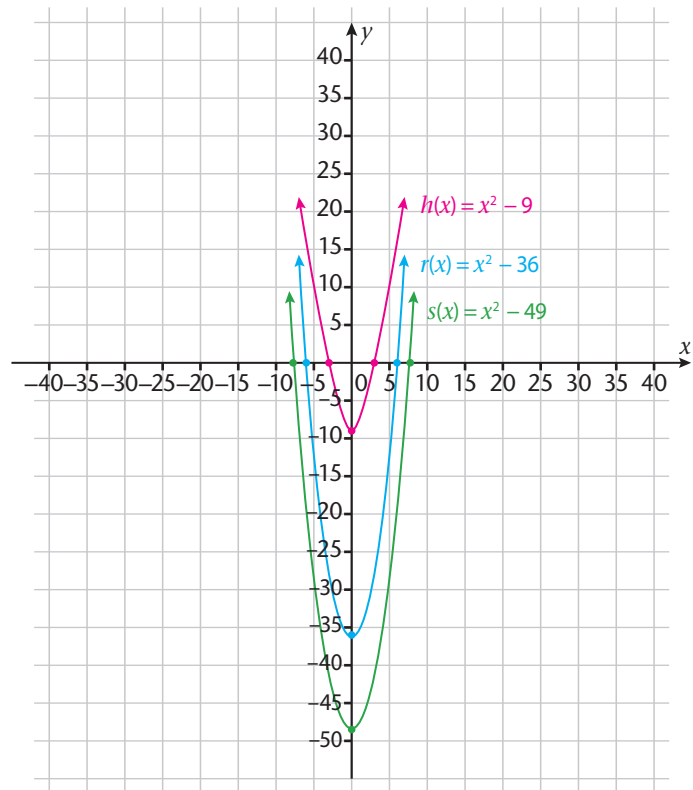
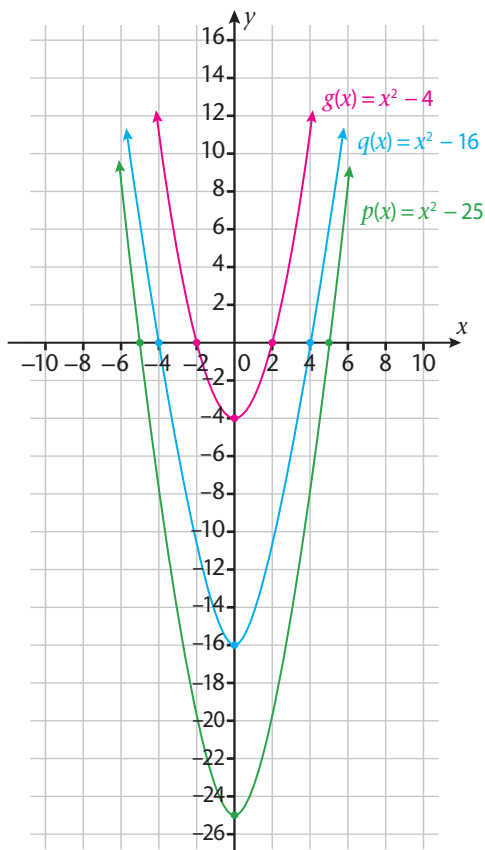

11.

Function	x-intercept	y-intercept	Turning point	Domain	Range	Axis of symmetry
(a) $g(x) = x^2$	(0; 0)	(0; 0)	(0; 0)	$x \in \mathbb{R}$	$y \geq 0$	$x = 0$
(b) $h(x) = x^2 - 4$	(-2; 0), (2; 0)	(0; -4)	(0; -4)	$x \in \mathbb{R}$	$y \geq -4$	$x = 0$
(c) $q(x) = x^2 - 16$	(-4; 0), (4; 0)	(0; -16)	(0; -16)	$x \in \mathbb{R}$	$y \geq -16$	$x = 0$
(d) $p(x) = x^2 - 25$	(-5; 0), (5; 0)	(0; -25)	(0; -25)	$x \in \mathbb{R}$	$y \geq -25$	$x = 0$
(e) $r(x) = x^2 - 36$	(-6; 0), (6; 0)	(0; -36)	(0; -36)	$x \in \mathbb{R}$	$y \geq -36$	$x = 0$
(f) $s(x) = x^2 - 49$	(-7; 0), (7; 0)	(0; -49)	(0; -49)	$x \in \mathbb{R}$	$y \geq -49$	$x = 0$
(g) $u(x) = x^2 - 121$	(-11; 0), (11; 0)	(0; -121)	(0; -121)	$x \in \mathbb{R}$	$y \geq -121$	$x = 0$
(h) $v(x) = x^2 - 81$	(-9; 0), (9; 0)	(0; -81)	(0; -81)	$x \in \mathbb{R}$	$y \geq -81$	$x = 0$

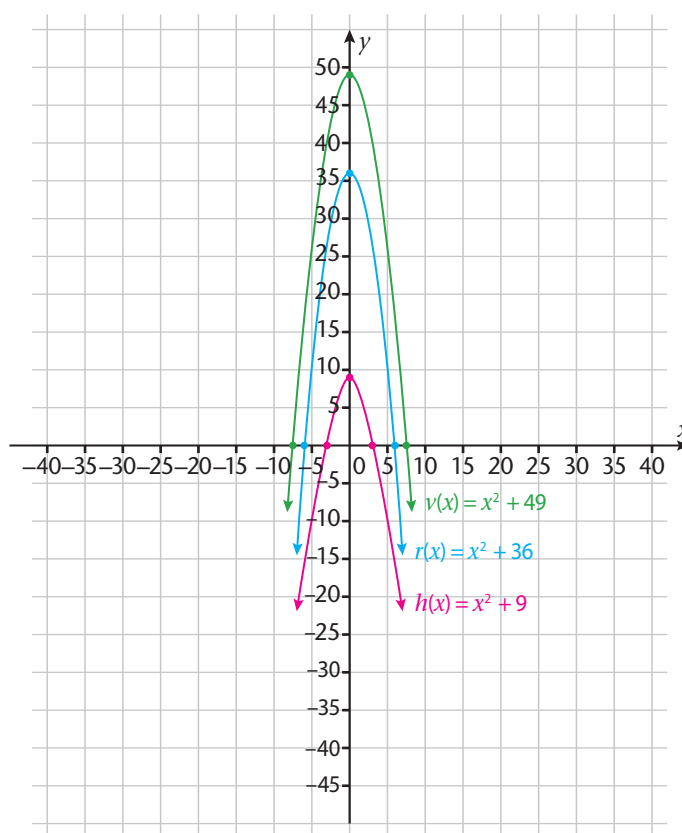
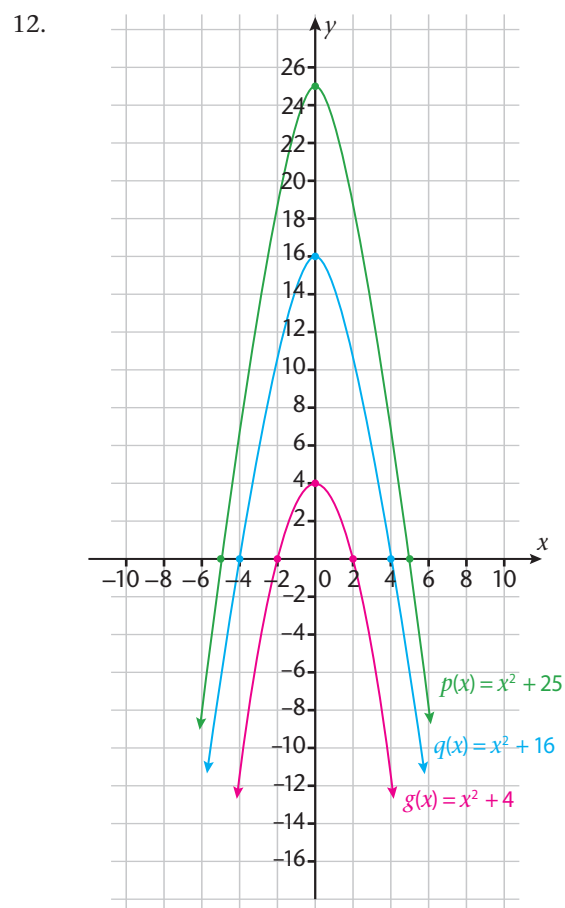

13.

Function	x-intercept	y-intercept	Turning point	Domain	Range	Axis of symmetry
(a) $g(x) = x^2$	(0; 0)	(0; 0)	(0; 0)	$x \in \mathbb{R}$	$y \leq 0$	$x = 0$
(b) $h(x) = -x^2 + 4$	(-2; 0), (2; 0)	(0; 4)	(0; 4)	$x \in \mathbb{R}$	$y \leq 4$	$x = 0$
(c) $q(x) = -x^2 + 16$	(-4; 0), (4; 0)	(0; 16)	(0; 16)	$x \in \mathbb{R}$	$y \leq 16$	$x = 0$
(d) $p(x) = -x^2 + 25$	(-5; 0), (5; 0)	(0; 25)	(0; 25)	$x \in \mathbb{R}$	$y \leq 25$	$x = 0$
(e) $r(x) = -x^2 + 36$	(-6; 0), (6; 0)	(0; 36)	(0; 36)	$x \in \mathbb{R}$	$y \leq 36$	$x = 0$
(f) $s(x) = -x^2 + 49$	(-7; 0), (7; 0)	(0; 49)	(0; 49)	$x \in \mathbb{R}$	$y \leq 49$	$x = 0$
(g) $u(x) = -x^2 + 121$	(-11; 0), (11; 0)	(0; 121)	(0; 121)	$x \in \mathbb{R}$	$y \leq 121$	$x = 0$
(h) $v(x) = -x^2 + 81$	(-9; 0), (9; 0)	(0; 81)	(0; 81)	$x \in \mathbb{R}$	$y \leq 81$	$x = 0$

14.

	$q < 0$	$q > 0$
$a > 0$	It as if the graph of the quadratic function is being pulled downwards. The y -coordinate of the turning point changes from 0 to a negative value. The graph of the function has two intercepts.	It as if the graph of the quadratic function is being pulled upwards. The y -coordinate of the turning point changes from 0 to a positive value. The graph of the function has no-intercepts.
$a < 0$	It as if the graph of the quadratic function is being pulled downwards. The y -coordinate of the turning point changes from 0 to a negative value. The graph of the function has no intercepts.	It as if the graph of the quadratic function is being pulled upwards. The y -coordinate of the turning point changes from 0 to a positive value. The graph of the function has two intercepts.

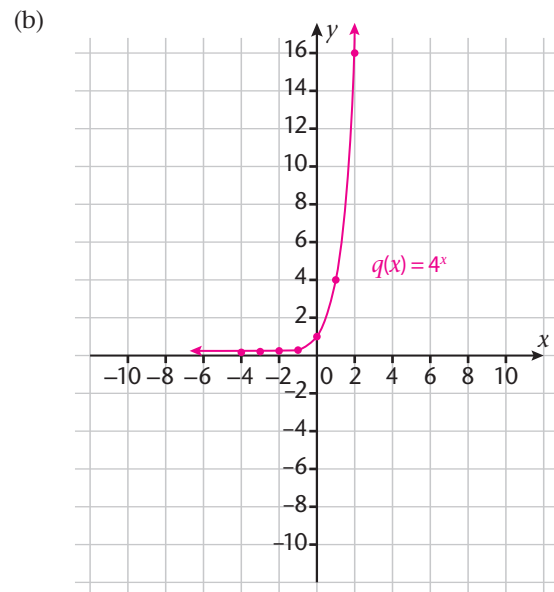
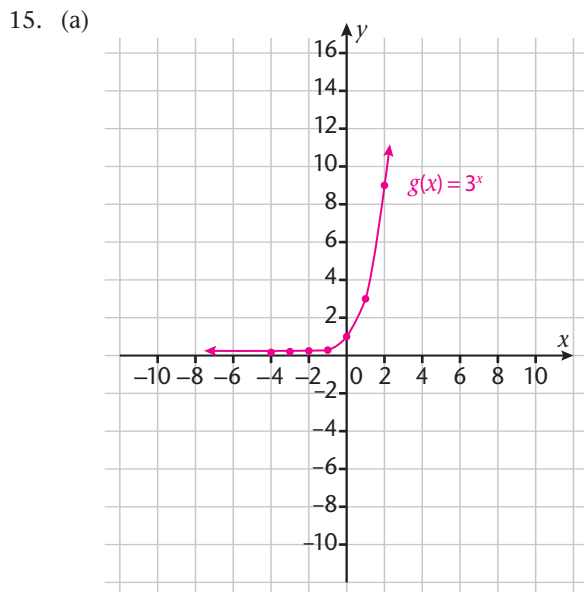

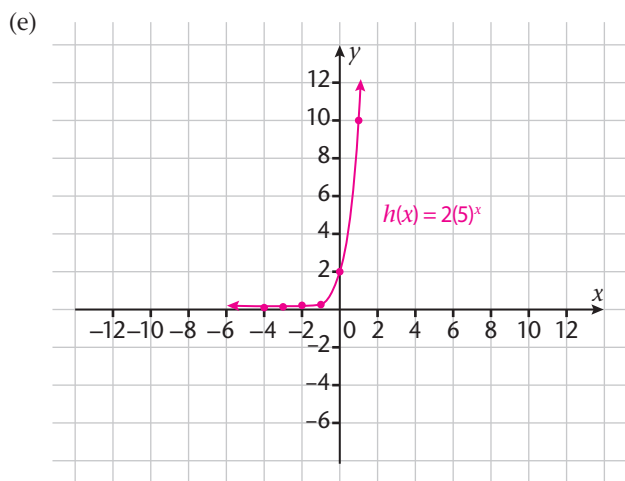
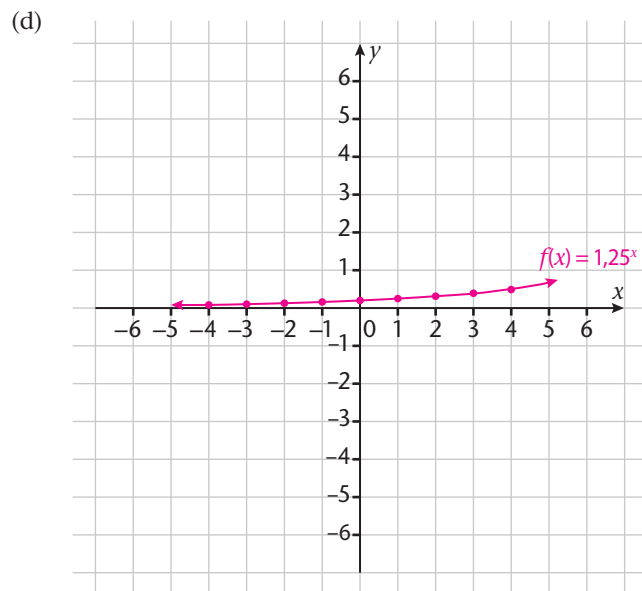
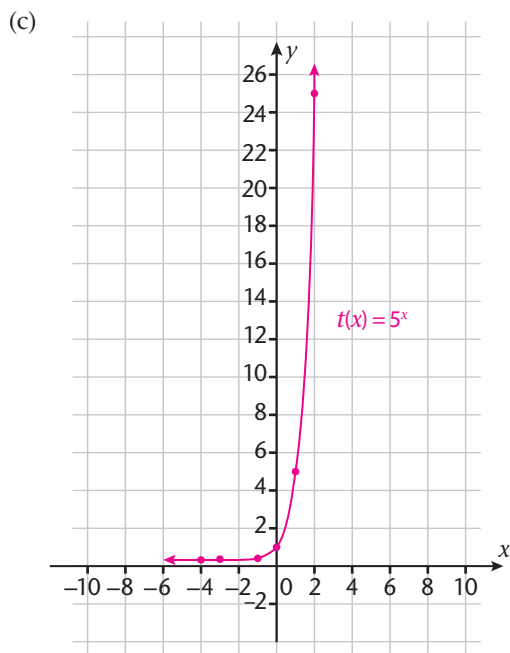

16.

Function	Intercepts	Domain	Range	Asymptote
(a) $g(x) = 3^x$	(0; 1)	$x \in \mathbb{R}$	$y > 0$	$y = 0$
(b) $q(x) = 4^x$	(0; 1)	$x \in \mathbb{R}$	$y > 0$	$y = 0$
(c) $t(x) = 5^x$	(0; 1)	$x \in \mathbb{R}$	$y > 0$	$y = 0$
(d) $f(x) = 1,25^x$	(0; 1)	$x \in \mathbb{R}$	$y > 0$	$y = 0$
(e) $h(x) = 2(5)^x$	(0; 2)	$x \in \mathbb{R}$	$y > 0$	$y = 0$
(f) $y = 3(2)^x$	(0; 3)	$x \in \mathbb{R}$	$y > 0$	$y = 0$
(g) $y = 2(2)^x$	(0; 2)	$x \in \mathbb{R}$	$y > 0$	$y = 0$
(h) $y = 2(3)^x$	(0; 2)	$x \in \mathbb{R}$	$y > 0$	$y = 0$
(i) $y = 2(4)^x$	(0; 2)	$x \in \mathbb{R}$	$y > 0$	$y = 0$

17. (a)

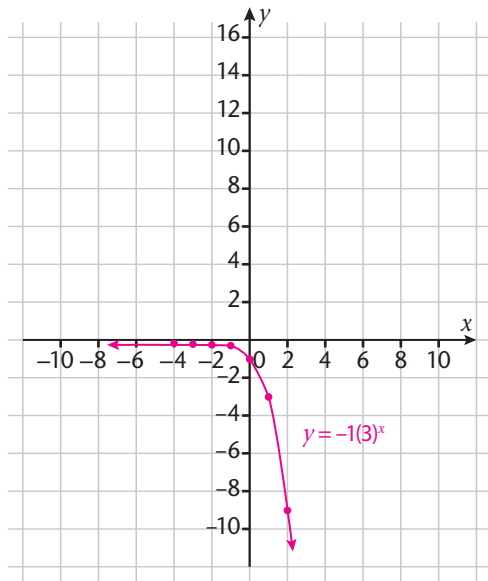

(b)

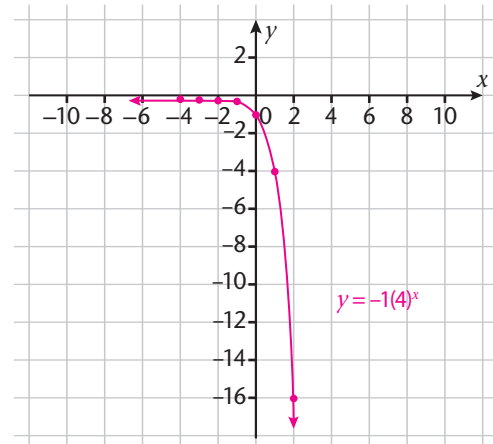

(c)

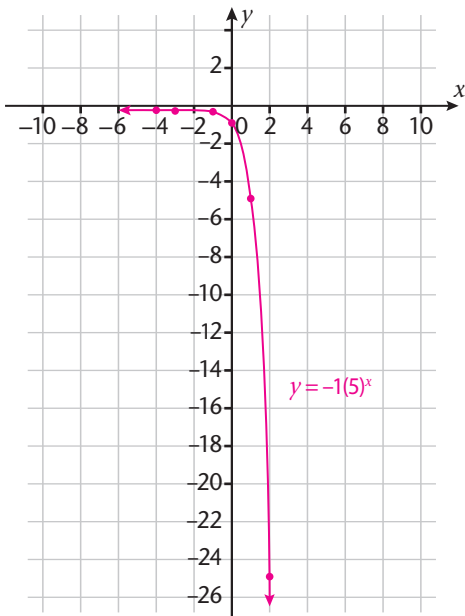

(d)

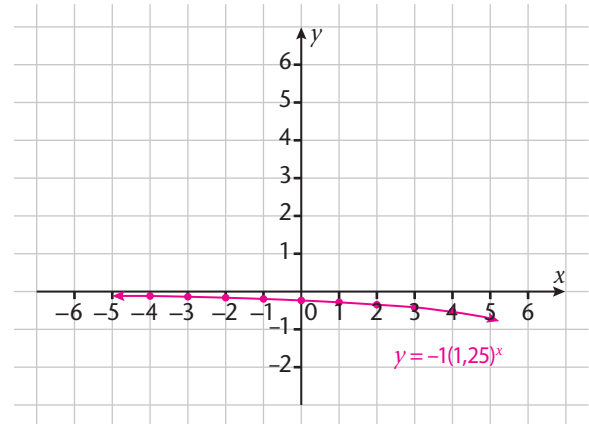

(e)

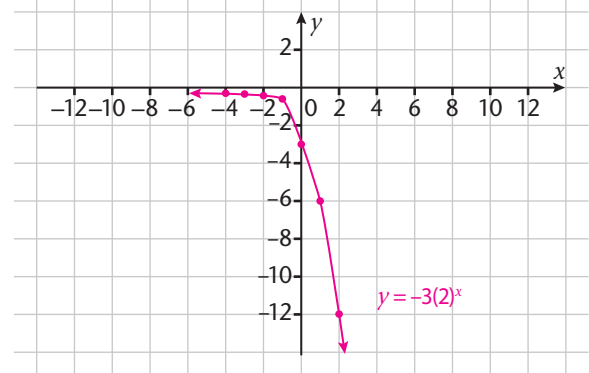
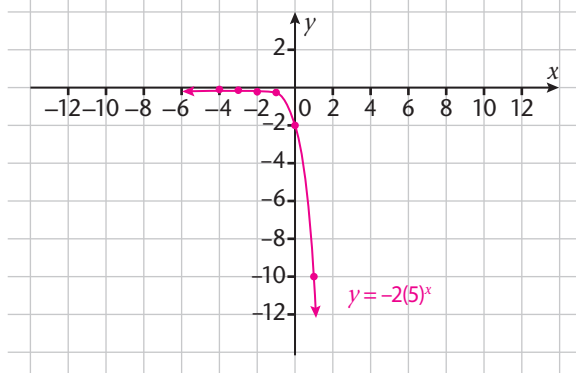

18.	Function	intercepts	Domain	Range	Asymptote
	(a) $y = -1(3)^x$	(0; -1)	$x \in \mathbb{R}$	$y < 0$	$y = 0$
	(b) $y = -1(4)^x$	(0; -1)	$x \in \mathbb{R}$	$y < 0$	$y = 0$
	(c) $y = -1(5)^x$	(0; -1)	$x \in \mathbb{R}$	$y < 0$	$y = 0$
	(d) $y = -1(1,25)^x$	(0; -1)	$x \in \mathbb{R}$	$y < 0$	$y = 0$
	(e) $y = -2(5)^x$	(0; -2)	$x \in \mathbb{R}$	$y < 0$	$y = 0$
	(f) $y = -3(2)^x$	(0; -3)	$x \in \mathbb{R}$	$y < 0$	$y = 0$

19. (a) the same
 (b) different, 3^x is all positive y -values, and $-1(3)^x$ is all negative y -values
 (c) different, 3^x above 0, and $-1(3)^x$ below 0
 (d) the same
20. (a) 3^x graph go upward, and $-1(3)^x$ graph goes downward
 (b) 3^x function increases, and $-1(3)^x$ function decreases

21. (a)

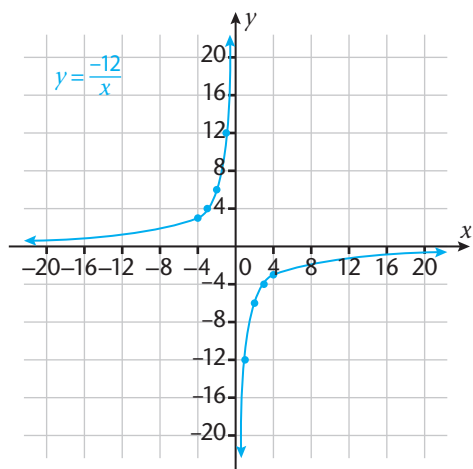

(b)

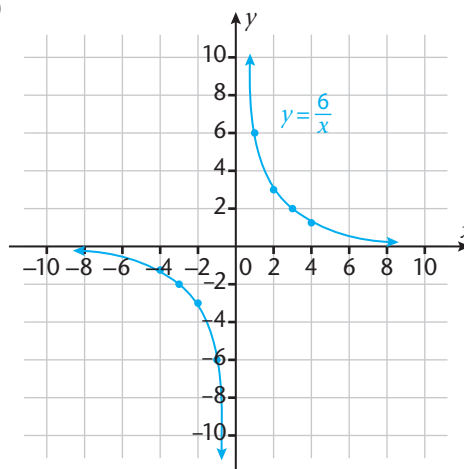

(c)

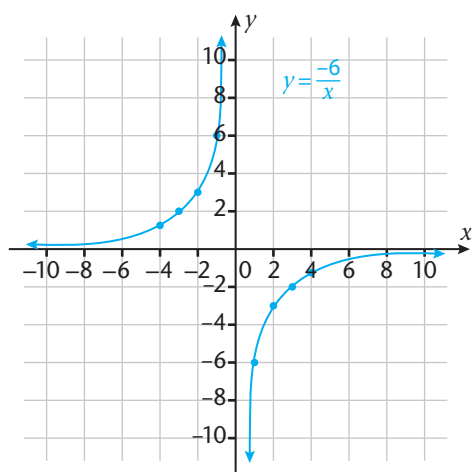

(d)

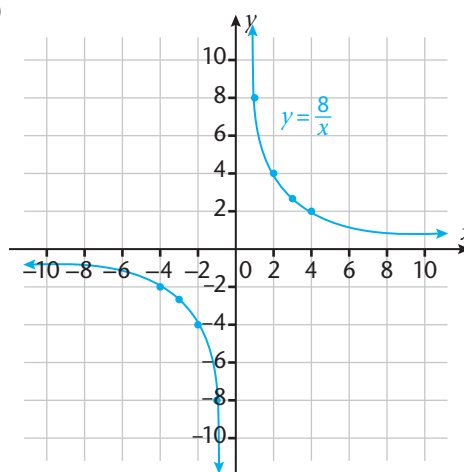

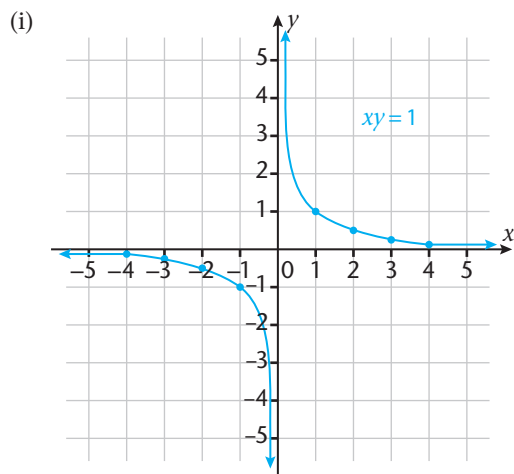
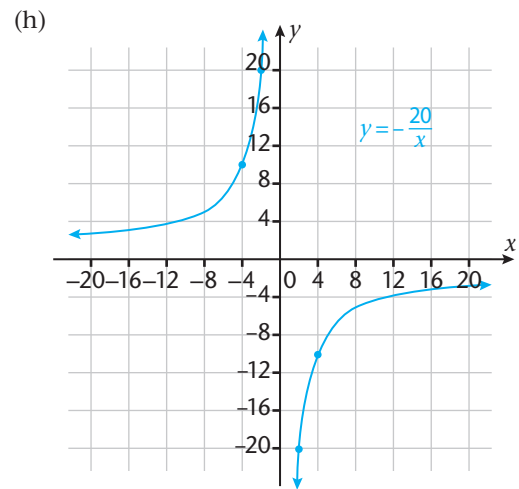
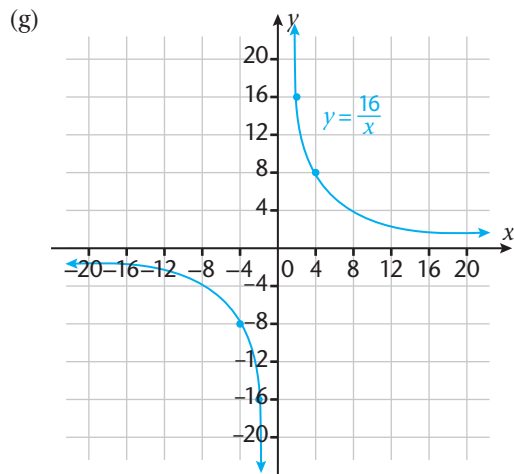
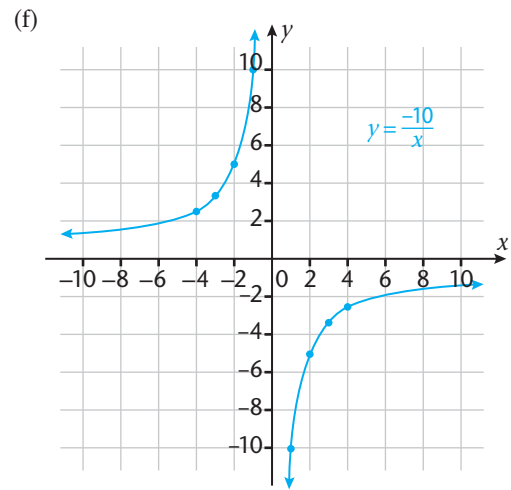
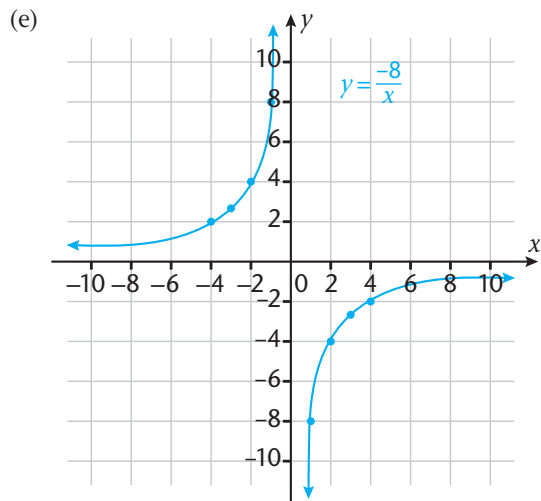

22.	Question 21 graphs	Domain	Range	Line of Symmetry	Asymptote
	(a)	$x \in \mathbb{R} \setminus \{0\}$	$y \in \mathbb{R} \setminus \{0\}$	$y = x$	$y = 0 \ \& \ x = 0$
	(b)	$x \in \mathbb{R} \setminus \{0\}$	$y \in \mathbb{R} \setminus \{0\}$	$y = -x$	$y = 0 \ \& \ x = 0$
	(c)	$x \in \mathbb{R} \setminus \{0\}$	$y \in \mathbb{R} \setminus \{0\}$	$y = x$	$y = 0 \ \& \ x = 0$
	(d)	$x \in \mathbb{R} \setminus \{0\}$	$y \in \mathbb{R} \setminus \{0\}$	$y = -x$	$y = 0 \ \& \ x = 0$
	(e)	$x \in \mathbb{R} \setminus \{0\}$	$y \in \mathbb{R} \setminus \{0\}$	$y = x$	$y = 0 \ \& \ x = 0$
	(f)	$x \in \mathbb{R} \setminus \{0\}$	$y \in \mathbb{R} \setminus \{0\}$	$y = x$	$y = 0 \ \& \ x = 0$
	(g)	$x \in \mathbb{R} \setminus \{0\}$	$y \in \mathbb{R} \setminus \{0\}$	$y = -x$	$y = 0 \ \& \ x = 0$
	(h)	$x \in \mathbb{R} \setminus \{0\}$	$y \in \mathbb{R} \setminus \{0\}$	$y = x$	$y = 0 \ \& \ x = 0$
	(i)	$x \in \mathbb{R} \setminus \{0\}$	$y \in \mathbb{R} \setminus \{0\}$	$y = -x$	$y = 0 \ \& \ x = 0$

23. it affects the shape of the graph

24. 2,5 calories

25. 140 g

26. (a)

x	-3	-2	-1	0	1	2	3
y	0	-5	-8	-9	-8	-5	0

26. (b) (0; -9)

27. (a) 30 feet

27. (b) 7,5 metres

27. (c) 6 meters is longer than 15 feet

CONSOLIDATION EXERCISES

1.

x	-4	-3	-2	-1	0	1	2	3	4
f(x)	-4	-3	-2	-1	0	1	2	3	4

(a) (0; 0)

(b) (0; 0)

(c) $x \in \mathbb{R}$

(d) $y \in \mathbb{R}$

2. (a) i. (0; 0) ii. $(-\frac{4}{3}; 0)$ iii. (1; 0)

(b) i. (0; 0) ii. (0; 4) iii. (0; 1)

(c) i. $x \in \mathbb{R}$ ii. $x \in \mathbb{R}$ iii. $x \in \mathbb{R}$

(d) i. $y \in \mathbb{R}$ ii. $y \in \mathbb{R}$ iii. $y \in \mathbb{R}$

3.

	$f(x) = 0$	$f(x) > 0$	$f(x) \geq 0$	$f(x) < 0$	$f(x) \leq 0$
$f(x) = x^2 - 4$	$x = -2, x = 2$	$x < -2, x > 2$	$x \leq -2, x \geq 2$	$-2 < x < 2$	$-2 \leq x \leq 2$
$f(x) = -x^2 + 16$	$x = -4, x = 4$	$-4 < x < 4$	$-4 \leq x \leq 4$	$x < -4, x > 4$	$x \leq -4, x \geq 4$
$f(x) = -x^2 - 4$	none	none	none	$x \in \mathbb{R}$	$x \in \mathbb{R}$
$f(x) = x^2 - 2$	$x = -2, x = 2$	$x < -\sqrt{2}, x > \sqrt{2}$	$x \leq -\sqrt{2}, x \geq \sqrt{2}$	$-\sqrt{2} < x < \sqrt{2}$	$-\sqrt{2} \leq x \leq \sqrt{2}$

4. (a)

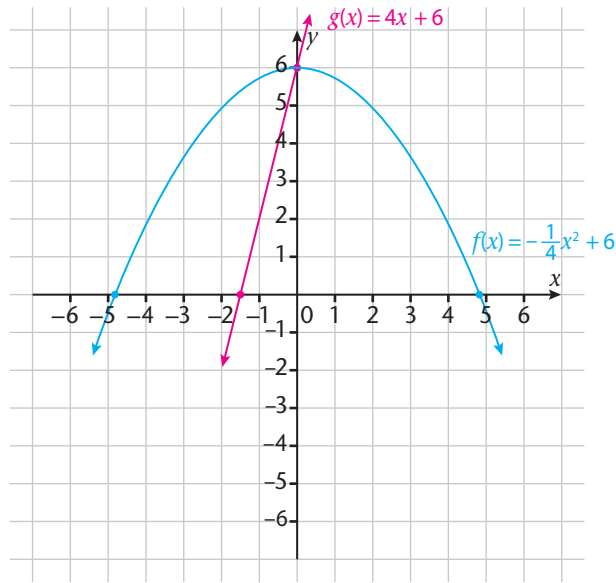

(b) $f(x) \geq 0$ for $-4,89 \leq x \leq 4,89$

$f(x) = g(x)$ for $x = 0$

$f(x) < g(x)$ for $x > 0$

(c) range of $f(x)$ is $y \leq 6$

range of $g(x)$ is $y \in \mathbb{R}$

(d) domain for both f and g is $x \in \mathbb{R}$

5. (a) $y = -1$ (b) $x \in \mathbb{R}$ (c) $y \leq 0$

(d) Maximum, $y = 0$ (e) $x < 0$ (f) $x > 0$

(g) yes

6. (a) $y = 4$ (b) (c) $y \geq 0$

(d) Minimum, $y = 0$ (e) $x > 0$ (f) $x < 0$

(g) yes

7. (a) $(0; -2)$ (b) $(0; 10)$

(c) $(0; 3)$ (d) $(0; -4)$

8.

	Intercept	Domain	Range
$g(x)$	$(0; 1)$	$x \in \mathbb{R}$	$y > 0$
$t(x)$	$(0; 1)$	$x \in \mathbb{R}$	$y > 0$
$h(x)$	$(0; 1)$	$x \in \mathbb{R}$	$y > 0$
$p(x)$	$(0; 1)$	$x \in \mathbb{R}$	$y > 0$

9. (a)

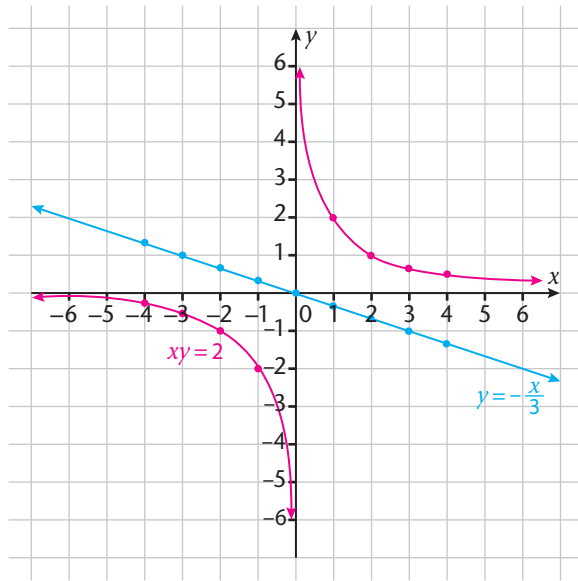

(b) domain for $xy = 2$ is $x \in \mathbb{R} \setminus \{0\}$

domain for $y = -\frac{x}{3}$ is $x \in \mathbb{R}$

(c) range for $xy = 2$ is $y \in \mathbb{R} \setminus \{0\}$

domain for $y = -\frac{x}{3}$ is $y \in \mathbb{R}$

10. (a) $y = \frac{5}{x}$

(b) $y = \frac{-2}{x}$

(c) $y = \frac{6}{x}$

(d) $y = \frac{-12}{x}$

CHAPTER 8 GEOMETRY ANSWERS

EXERCISES

1. (a) $\angle A_2 = 142^\circ$; $\angle A_3 = 38^\circ$; $\angle A_4 = 142^\circ$;
 (b) draw an arrow along GH, pointing away from G; rotate it anticlockwise around G until the arrowhead points along GF; the arrow has rotated through half of a revolution; therefore, the angle between GH and GF must be half of $3\ 600 = 1\ 800$; use a similar sort of argument to explain why vertically opposite angles are equal
2. (a) x and k ; b and q
 (b) a and x ; q and e ; k and p ; t and b
 (c) e and b ; x and p ; q and t ; a and k
 (d) q and x ; b and k
 (e) e and p ; p and b ; b and x ; x and e ;
 q and k ; k and t ; t and a ; a and q ;
 x and q ; a and e ; k and b ; t and b
3. (a) they must all be perfect cylinders with exactly the same cross-sectional diameter
 (b) if circles are drawn between two lines so that they just touch the two lines, then all the circles will have the same diameter if the lines are parallel; the diameters will be different when the two lines are not parallel
4. (c) Non-parallel lines: Two lines are not parallel when circles they are both tangent to, have different diameters.; Another way: Two lines are non-parallel if they are not a fixed distance apart along their lengths.
 Parallel lines: Two lines are parallel when circles they are both tangent to, have the same diameters. Another way: Two lines are parallel if they are the same distance apart anywhere along their lengths
5. (c) Non parallel lines: Any transversal drawn through two non-parallel lines will result in corresponding angles being unequal, alternate angles being unequal and co-interior angles not being supplementary.
 Parallel lines: Any transversal drawn through two parallel lines will result in corresponding angles being equal, alternate angles being equal, and co-interior angles being supplementary.
6. You should find that the opposite segments are of equal length. What you have constructed here are parallelograms. When four lines intersect to form a closed quadrilateral in such a way that the opposite sides of the parallelogram are equal, then it means that both pairs of opposite lines are parallel.
9. (c) the statement is correct and should make sense to you; it follows that (d) should be easy to answer for you
10. $x = 20^\circ$; $y = 360$; $z = 40^\circ$
11. $z = 65^\circ$
12. $c = 42,8^\circ$; $e = 47,2^\circ$
13. (a) $y = 42^\circ$ (b) $y = 69^\circ$
14. (a) $a = 32^\circ$; $c = 58^\circ$ (b) $f = 15^\circ$
15. (a) False: Some acute angled triangles are scalene triangles, others are not (e.g. equilateral triangles and isosceles triangles).
 (b) False: All equiangular triangles are equilateral. Equiangular and equilateral are synonyms when we are speaking of triangles.
 (c) False: The shortest side is opposite the smallest angle, and the longest side opposite the largest angle.
16. all isosceles
19. they are congruent
20. Ways of drawing a triangle: (I) measure one side length and the two angles at each end of that side – redraw using a ruler and a protractor; (II) measure the lengths of sides and the angle between them – draw one side, measure off the angle and then draw the other side; use a ruler and a protractor; (III) measure the lengths of all three sides – draw one with a ruler and use a pair of compasses to mark off the remaining two lengths as arcs. See the table on p. 279.

22. (a) Yes; [SAS] (b) No; OP in $\triangle OPQ$ corresponds to BA in $\triangle BAC$, not to BC
 (c) Yes; [SAS] (d) Yes; [SSS] (e) Yes; [AAS]
 (f) Yes; [RHS] (g) Yes; [SSS]
23. (a) $\angle BCA = 38^\circ$; $\angle QPR = 37^\circ$; $\angle PQR = 105^\circ$; $\angle QRP = 38^\circ$
 (b) because $AP + PC = PC + CR$ [given that $AP = CR$]
 (c) Yes; [AAS]
24. **Hint:** it's all about the two angles at P
25. [SSS]
26. (a) [AAS]
 (b) **Hint:** What can be deduced about $\angle ARI$ and $\angle AIR$? ...
 (c) **Hint:** What can be said about $\triangle TAO$ and $\triangle TAH$? ...
27. **Hint:** Imagine a rectangle that the right-hand triangle *just* fits into... Pythagoras will lead you there.
32. The triangle in Ex 29 has all its sides 1,5 times longer than the corresponding sides of triangle in Ex 28; the interior angles of these two triangles are exactly the same. The triangles in Ex 30 and 31 have the same corresponding sides and you should find that their corresponding sides are in the same ratio. Ex 33 should confirm these ideas for you.
34. (a) $\triangle MAD \parallel \triangle HAT$
 (b) $y = 2$ units
35. (a) ... they are similar [corresponding sides in proportion]
 (b) 1:3; 1:9
36. (b) OQ = 8 units; 9,5 units
37. (d) 1
38. (a) 1,25 units
 (b) 3,5 units
39. (c) FN; FO; GD (d) No
40. (c) congruent (d) equal
 (e) axis of symmetry (f) perpendicular; bisects
 (g) and (h) compare and discuss your findings with some friends once you have completed this; be sure to be able to explain your responses convincingly to each other
41. (d) congruent; equal
 (e) bisect
 (f) **Hint:** alternate angles
 (g) and (h) discuss, compare, convince yourself
 (i) yes, if the parallelogram happens to be a rhombus; no
42. (a) yes; no (rhombuses are parallelograms however); yes; no (rhombuses are kites though); yes
 (c) yes, they have all the properties of parms
 (d) **Hint:** lengths of sides; angle at which diagonals intersect; four triangles formed by intersecting diagonals and sides; ... more
 (g) yes, if the parallelogram happens to be a rhombus; no
43. (b) and (c) lengths of sides; angle of intersection of diagonals; axes of symmetry (all squares are kites, but non-square rectangles are not); ... more
 (d) no (however a square is both a rectangle and a rhombus)
 (e) yes
44. (d) no, true trapeziums are not parallelograms (although parallelograms are all trapeziums); yes; yes; yes; yes

45. (e)

	Fig A	Fig B	Fig C	Fig D	Fig E
Two line segments are equal	yes	no	yes	no	no
At least one line segment bisects the other one	yes	yes	yes	yes	yes
Two line segments bisect each other	yes	no	yes	yes	yes
Two line segments are perpendicular	yes	yes	no	no	yes

- (f) Fig A: all four small triangles, as are the four bigger ones;
 Fig B: $\triangle EHW$ and $\triangle EFW$; $\triangle GWH$ and $\triangle GWF$; $\triangle EHG$ and $\triangle EFG$
 Fig C: $\triangle IXJ$ and $\triangle LXX$; $\triangle IXL$ and $\triangle KXJ$; the four large triangles
 Fig D: $\triangle MYN$ and $\triangle OYP$; $\triangle PYM$ and $\triangle NYO$; $\triangle MPN$ and $\triangle ONP$; $\triangle MPO$ and $\triangle ONM$
 Fig E: all four small triangles; $\triangle TQR$ and $\triangle RST$; $\triangle QTS$ and $\triangle SRQ$

(g)

	Fig A	Fig B	Fig C	Fig D	Fig E
Two diagonals are equal	yes	no	yes	no	no
At least one diagonal bisects the other one	yes	yes	yes	yes	yes
Two diagonals bisect each other	yes	no	yes	yes	yes
Two diagonals are perpendicular	yes	yes	no	no	yes
Opposite sides are parallel	yes	no	yes	yes	yes
Two adjacent sides are equal and other two adjacent sides are also equal	yes	yes	no	no	yes
Two opposite angles equal	yes	yes	yes	yes	yes
Two opposite angles equal and other two opposite angles also equal	yes	no	yes	yes	yes

46. (a) parallel; equal in length
47. (a) true (b) not always; angle must be included
 (c) false; only if all the interior angles are equal (squishy pentagon)
 (d) true (e) true (f) true
 (g) false; the sides and angles must be in corresponding positions (See Ex 22(b))
 (h) false; although squares and rhombuses are kites, and have diagonals intersecting at right angles (counterexample: it is possible to construct a true trapezium with diagonals cutting at 90°)
 (i) false; they need to be the same sides (counterexample: an isosceles trapezium has one pair of sides parallel and the other pair equal in length)
48. (a) B; D (b) E (c) A (d) B; C
 (e) D (f) B; D (g) B (h) C; D; F
 (i) C (j) A; D; E; F
50. you should agree
51. (a) true
 (b) false: construct a kite counterexample, or a trapezium counterexample
 (c) true
 (d) false; all rhombuses (even non-square ones) are both kites and trapeziums
52. (a) E (b) F; I (c) B; E (d) G
 (e) none (f) A; B; C; E; H
53. (a) $a = 36^\circ$; $b = 144^\circ$; $c = 36^\circ$; $d = 36^\circ$; $e = 29^\circ$; $f = 60^\circ$
 (b) $p = 5$ units; $q = 5$ units; $r = 3$ units; $s = 10$ units (**Hint:** What is ABCD?)
54. $b = 120^\circ$; $a = 60^\circ$; $x = 50^\circ$; $y = 100^\circ$; $z = 30^\circ$
55. (a) 40 mm^2 (b) 4 mm (c) 12,5 mm

56. left-hand triangle: 12 units; 16 units; 20 units; right-hand triangle: 5 units; 12 units; 13 units
58. (a) $p = 1,73$ units (b) $w = 1,41$ units (c) $\theta = 90^\circ$
 (d) $x = 5$ units (e) $z = 18,6$ units
59. (a) $x = 20$ units (b) $\angle BAC = 450$ (c) 296 square units (d) perimeter = 76,28 units
60. **Hint:** $\triangle IJK$
61. (e) 1:1; 1:2; 2:1
 (f) $SR = SP = 8,09$ units; $OS = 5,88$ units; $PQ = 11,8$ units
62. **Hint:** the three imaginary triangles

CONSOLIDATION EXERCISES

- [AAS]
- $x = 50^\circ$
- $x = 108^\circ; y = 90^\circ$
- use $\triangle BEF$ and $\triangle BDC$ to show that $BF = FG$; use another pair of similar \triangle s to show $FG = GC$
- find two equations in x and y ; solve simultaneously; $x = 18^\circ$ and $y = 72^\circ$
- $c = 4$ units
- (a) two possible answers: 13,5 m or 24 m
 (b) two possible answers based on (a): 22,5 m or 30 m
 (c) two possible answers based on (b): 2 160 m² or 2 880 m²
- $1,85 \times 10^5$ m
- 7,42 m
- 2,06 m
- (a) show a pair of corresponding angles to be equal
 (b) $IJ = 0,666$ units; $BI = 1,104$

CHAPTER 9 ANALYTICAL GEOMETRY ANSWERS

EXERCISES

- 1 (a) 3 (b) 4
- 2 The x -coordinate tells us how far from the origin the point is on the horizontal axis.
The y -coordinate tells us how far up or down the point is along the vertical axis.
- 3 B(2; 0), C(-2; -2), D(0; -4), E(0; 5), F(-1; 0), G(3; -3), H(0; 0), I(1; 3) J(-2; 4)

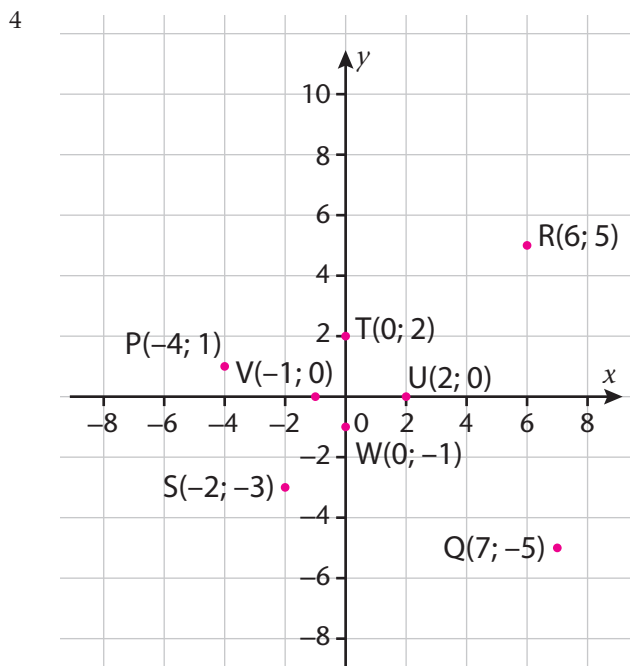

- 5 (a) 6 units (b) 4 units
(c) 3 units (d) 20 units
- 6 (a) 4 units (b) 3 units
(c) 13 units (d) 50 units
- 7 (a) 5 units (b) 13 units
(c) 10 units (d) $\sqrt{164}$ units
- 8 (a) $d = \sqrt{50}$ units (b) $\sqrt{5}$ units
(c) $\sqrt{234}$ units (d) $\sqrt{185}$ units
- 9 (a) $\sqrt{5}$ units (b) $\sqrt{20}$
(c) $\sqrt{200}$ (d) $\sqrt{8}$
- 10 (a) $\sqrt{20}$ units; $\sqrt{20}$ units; $\sqrt{40}$ units
(b) Yes, sum of the squares of two sides of the triangle is equal to the square of the third side of the triangle.

- 11 (a) $\sqrt{32}$ units; 8 units; $\sqrt{32}$ units \therefore Isosceles & right angled
(b) $\sqrt{13}$; $\sqrt{10}$ units; $\sqrt{5}$ units \therefore Scalene triangle
(c) $\sqrt{26}$ units; $\sqrt{8}$ units; $\sqrt{18}$ units \therefore Right-angled triangle
- 12 Proven with two sides being equal, $EF = DF$
- 13 (a) proven by showing all sides are equal
(b) proven by showing opposite side are equal
- 14 (a) (0; 6) (b) $(3; -\frac{1}{2})$
(c) (8; 0) (d) (5; 2)
(e) (6; 0) (f) (4; -2)
- 15 (a) (0; 6) (b) $(3; -\frac{3}{2})$
(c) (8; 0) (d) (8; 2)
(e) (6; 0) (f) (4; -2)
- 16 (a) (-4; 5) (b) $(\frac{3}{2}; -\frac{5}{2})$
(c) $(7; \frac{3}{2})$ (d) $(\frac{9}{2}; \frac{7}{2})$
(e) $(\frac{11}{2}; 1)$ (f) (4; 0)
- 17 (a) (0; 5) (b) $(-\frac{3}{2}; 2)$
(c) (0; 0) (d) $(5; \frac{1}{2})$
- 18 (a) C(-3; -3) (b) G(7; 1)
(c) F(10; -10) (d) A(-3; -1)
- 20 (a) $m_{CD} = \frac{8}{5}$ (b) $m_{AB} = 2$
(c) $m_{EF} = -1$ (d) $m_{GH} = \frac{1}{4}$
- 21 (a) $m_{AB} = -\frac{1}{3}$ (b) $m_{CD} = 1$
(c) $m_{EF} = \frac{5}{3}$ (d) $m_{GH} = -1$
- 22 (a) not parallel (b) not parallel
(c) not parallel (d) parallel
(e) not parallel (f) parallel
- 25 (a) $m = -\frac{1}{10}$ (b) $m = \frac{1}{10}$
(c) $m = -\frac{4}{3}$ (d) $m = \frac{2}{3}$
(e) $m = 1$ (f) $m = \text{undefined}$
(g) $m = 0$

- 26 (a) $m_{AC} = 1$ $m_{BD} = -1$
 (b) $m_{AC} \times m_{BD} = -1 \therefore$ They are perpendicular to each other
 (c) Square, Kite or Rhombus. Diagonal are perpendicular
- 28 Trapezium
- 29 (a) $y = x$ (b) $y = 0$
 (c) $x = 0$ (d) $y = 2x$
 (e) $y = \frac{1}{2}x$ (f) $y = -\frac{10}{7}x + \frac{12}{7}$

CONSOLIDATION EXERCISES

- 1 (a) $\sqrt{113}$ (b) $(\frac{1}{2}; 0)$ (c) $-\frac{8}{7}$
- 2 (a) $d_{AB} = \sqrt{50}$ $d_{AC} = \sqrt{50}$ $d_{BC} = 10$
 (b) Isosceles (c) (6; 6)
 (d) $m_{AM} = -\frac{4}{3}$
- 3 (a) $d_{ST} = \sqrt{63}$; $d_{TQ} = \sqrt{68}$; $d_{QR} = \sqrt{63}$; $d_{RS} = \sqrt{68}$
 (b) $m_{SR} = 4$; $m_{TQ} = 4$; $m_{ST} = \frac{2}{7}$; $m_{QR} = \frac{2}{7}$
 (c) $M_{SR} = (6; 3)$; $M_{TQ} = (-1; 1)$; $M_{ST} = (\frac{3}{2}; -2)$;
 $M_{QR} = (\frac{7}{2}; 6)$
 (d) Parallelogram
- 4 (a), (b), (c), (d) and (e) all have positive gradients and (f) has a negative gradient
- 5 (a) $k = 10$ (b) $k = 5$
- 6 $d = 7$ and $c = -7$
- 7 B(17; -7)

CHAPTER 10 CIRCLES, ANGLES, AND ANGULAR MOVEMENT ANSWERS

EXERCISES

1. (b)

Circle	Radius (cm)	diameter	circumference	$\frac{\text{circumference}}{\text{diameter}}$
A	3	6	18,86	3,143 3
B	4	8	25,14	3,142 5
C	5	10	31,43	3,143 0
D	6	12	37,71	3,142 5
E	7	14	44	3,142 9
F	8	16	50,29	3,143 1
G	9	18	56,57	3,142 8

(d) Average value $\approx 3,14$ (e) No

2. (a) $\pi = \frac{c}{d}$ or $\pi = \frac{c}{2r}$.

(b) (i) 3,14 (ii) 3,14 (iii) 3,14 (iv) 3,14

(c) Similar

3. (a) 188,40 cm (b) 18,84 cm (c) 314 m (d) 4 710 mm

4.

	Number of equal sectors	The angle of each sector
(a)	2	180°
(b)	4	90°
(c)	5	72°
(d)	6	60°
(e)	9	40°
(f)	12	30°
(g)	20	18°
(h)	30	12°
(i)	40	9°
(j)	90	4°
(k)	120	3°
(l)	360	1°

5. (a)

Words	Number of revolutions	Number of degrees
No turn	0	0
Quarter turn	$\frac{1}{4}$	90
Half turn	$\frac{1}{2}$	180
Three-quarter turn	$\frac{3}{4}$	270
Full turn	1	360
Twelfth turn	$\frac{1}{12}$	30
Eight turn	$\frac{1}{8}$	45
Sixth turn	$\frac{1}{6}$	60
Fifth turn	$\frac{1}{5}$	72

6. (a) $120^{\circ}32'2''$ (b) $97^{\circ}34'5''$ (c) $33^{\circ}14'2''$ (d) $40^{\circ}59'$ (e) $238^{\circ}7'23''$ (f) $3\ 031\ 303^{\circ}$
 (g) $107^{\circ}30'$ (h) $342^{\circ}3'$
7. (a) $100,192^{\circ}$ (b) $90,017^{\circ}$ (c) $204,483^{\circ}$ (d) $28,246^{\circ}$ (e) $302,396^{\circ}$
8. (a) $120^{\circ}32'2,4''$ (b) $97^{\circ}34'4,8''$ (c) $33^{\circ}14'2,4''$ (d) $40^{\circ}59'13,2''$ (e) $238^{\circ}7'22,8''$ (f) $3\ 031\ 303^{\circ}0'0''$
 (g) $107^{\circ}30'0''$ (h) $342^{\circ}3'0''$
9. (a) $100,192^{\circ}$ (b) $90,017^{\circ}$ (c) $204,483^{\circ}$ (d) $28,246^{\circ}$ (e) $302,396^{\circ}$

10.

Circle	radius	circumference	$\frac{\text{radius}}{\text{circumference}}$	arc length	$\frac{\text{arc length}}{\text{radius}}$
Red	1cm	6,29	0,159	0,8	0,80
Blue	2cm	12,57	0,159	1,6	0,80
Green	3cm	18,86	0,159	2,4	0,80

11. (a) 2 rad (b) 6 rad (c) 2,5 rad (d) 4 rad (e) 1 rad
12. (a) 315° (b) 135° (c) 2° (d) 720° (e) 360° (f) 180°
 (g) 135° (h) 110° (i) 90° (j) 108° (k) 48° (l) 216°
 (m) 126° (n) 20° (o) 195°
13. (a) $\frac{1}{6}\pi$ rad (b) $\frac{5}{6}\pi$ rad (c) $\frac{31}{18}\pi$ rad (d) $\frac{7}{12}\pi$ rad (e) $\frac{1}{4}\pi$ rad (f) π rad
 (g) $\frac{11}{6}\pi$ rad (h) $\frac{1}{15}\pi$ rad (i) $\frac{1}{3}\pi$ rad (j) $\frac{7}{6}\pi$ rad (k) $\frac{23}{12}\pi$ rad (l) $\frac{13}{30}\pi$ rad
 (m) $\frac{5}{12}\pi$ rad (n) $\frac{5}{4}\pi$ rad (o) $\frac{157}{180}\pi$ rad (p) $\frac{47}{90}\pi$ rad (q) $\frac{2}{3}\pi$ rad (r) $\frac{4}{3}\pi$ rad
 (s) 0 rad (t) $\frac{131}{180}\pi$ rad

14.

Degree measure	0°	1°	$57,29^{\circ}$
Radian measure	0 rad	$\frac{\pi}{180}$	1 rad

15.

Multiples of 30° and $\frac{\pi}{6}$		Multiples of 45° and $\frac{\pi}{4}$		Multiples of 60° and $\frac{\pi}{3}$		Multiples of 90° and $\frac{\pi}{2}$	
degree	radian	degree	radian	degree	radian	degree	radian
30°	$\frac{1}{6}\pi$ rad	45°	$\frac{1}{4}\pi$ rad	60°	$\frac{1}{3}\pi$ rad	90°	$\frac{1}{2}\pi$ rad
60°	$\frac{1}{3}\pi$ rad	90°	$\frac{1}{2}\pi$ rad	120°	$\frac{2}{3}\pi$ rad	180°	π rad
90°	$\frac{1}{2}\pi$ rad	135°	$\frac{3}{4}\pi$ rad	180°	π rad	270°	$\frac{3}{2}\pi$ rad
120°	$\frac{2}{3}\pi$ rad	180°	π rad	240°	$\frac{4}{3}\pi$ rad	360°	2π rad
150°	$\frac{5}{6}\pi$ rad	225°	$\frac{5}{4}\pi$ rad	300°	$\frac{5}{3}\pi$ rad		
180°	π rad	270°	$\frac{3}{2}\pi$ rad	360°	2π rad		
210°	$\frac{7}{6}\pi$ rad	315°	$\frac{7}{4}\pi$ rad				
240°	$\frac{4}{3}\pi$ rad	360°	2π rad				
270°	$\frac{3}{2}\pi$ rad						
300°	$\frac{5}{3}\pi$ rad						
330°	$\frac{11}{6}\pi$ rad						
360°	2π rad						

16. (a) 345° (b) 135° (c) 225° (d) 130°
 (e) 255° (f) 90° (g) 220° (h) 120° (i) 30°
 17. (a) $\frac{2+\sqrt{2}}{2}$ (b) 0 (c) $-\frac{1}{2}$ (d) $\frac{2+\sqrt{2}}{2}$ (e) -1
 18. (a) 1,57 rad (b) $\frac{1}{2}\pi$ (c) $\frac{3}{2}\pi$ (d) $-\frac{1}{4}\pi$

19.	Revolution	Degree	Radian	Rough sketch
	1	360	2π	
	$\frac{1}{2}$	180°	π	
	$\frac{4}{45}$	32°	$\frac{8\pi}{45}$	
	$\frac{1}{4}$	90°	$\frac{1\pi}{2}$	
	$\frac{1}{3}$	120°	$\frac{2\pi}{3}$	
	$\frac{1}{12}$	30°	$\frac{1\pi}{6}$	
	$\frac{1}{9}$	40°	$\frac{2\pi}{9}$	
	$\frac{1}{6}$	60°	$\frac{1\pi}{3}$	

20. (a) $\frac{10}{9}\pi$ (b) 18,72 cm (c) $\frac{20}{9}\pi$ (d) 7,33 m (e) 17,25 cm (f) 0,21 m
 (g) (i) 23,56 cm (ii) 50,27 cm

CONSOLIDATION EXERCISE

1. (a) 251,20 cm (b) 1,256 km (c) 3 821,66 m
 2. (a) $89^\circ 39' 80''$ (b) $126^\circ 15'$ (c) $256^\circ 1' 12''$
 (d) $50^\circ 7' 22,8''$ (e) $330^\circ 15' 21,6''$ (f) $111^\circ 6' 36''$
 3. (a) $25,38^\circ$ (b) $70,09^\circ$ (c) $150,93^\circ$
 (d) $323,25^\circ$ (e) $5,51^\circ$ (f) $254,99^\circ$
 4. (a) 3 rad (b) 6 rad (c) 2 rad
 (d) 3 rad (e) 7 rad (f) 1,14 rad
 5. (a) 450° (b) 240° (c) 4° (d) $\left(\frac{270}{7}\right)^\circ$ (e) 900° (f) 250°
 6. (a) $\frac{13}{45}\pi$ rad (b) $\frac{1}{15}\pi$ rad (c) $\frac{79}{90}\pi$ rad (d) $\frac{65}{36}\pi$ rad (e) $\frac{7}{60}\pi$ rad (f) $\frac{22}{15}\pi$ rad
 7. (a) 570° (b) 774° (c) $1\ 305^\circ$ (d) $106,5^\circ$ (e) $532,80^\circ$ (f) 48°
 8. (a) 4,27 rad (b) 27,04 cm (c) 1,82 rad (d) 25,22 m (e) 23 cm (f) 0,55 m
 (g) (i) 41,23 cm (ii) 87,96 cm

CHAPTER 11 FINANCE AND GROWTH ANSWERS

EXERCISES

1.

If you pay back on	n , number of months you take to repay me	$A - P$, the total interest you owe me (to the nearest cent)	A , the total amount you owe me (to the nearest cent)
1 March 2015	0	R0	R12 500
1 April 2015	1	R218,75	R12 718,75
1 May 2015	2	R437,50	R12 937,50
1 June 2015	3	R656,25	R13 156,25
1 July 2015	4	R875	R13 375
1 August 2015	5	R1 093,75	R13 593,75
1 September 2015	6	R1 312,50	R13 812,50
1 October 2015	7	R1 531,25	R14 031,25
1 November 2015	8	R1 750	R14 250
1 December 2015	9	R1 968,75	R14 468,75
1 January 2016	10	R2 187,50	R14 687,50
1 February 2016	11	R2 406,25	R14 906,25
1 March 2016	12	R2 625	R15 125

- (a) It increases by adding $P \times i = R218,75$ each time
 (b) $1,75 \times n\%$ in each case
 (c) Make sure scales are chosen to maximise spread of plotted points

Linear plot

Should not connect dots strictly speaking, since new A for a month is calculated on the first day of each month, and holds for the whole month (a step graph would be more appropriate but is unnecessary at this level)

- (d) Some (many?) may struggle to see that A is a linear function of n : $A = (ip)n + P$ where the gradient is ip and the A -intercept (the 'y-cut') is P
 (e) Strange because the moment Mimi transfers the money to Modiba's account he will owe her the first months' interest along with the principal; however, setting $n = 0$ in the formula outputs the principal value P , so there is mathematical sense to including $n = 0$ in the formula.

2. (a)

Number of months until Modiba pays Mimi	1	2	3	4	5	...	n
Multiplication factor in algebraic form	$1 + \frac{1,75}{100}$	$1 + 2 \times \frac{1,75}{100}$	$1 + 3 \times \frac{1,75}{100}$	$1 + 4 \times \frac{1,75}{100}$	$1 + 5 \times \frac{1,75}{100}$...	$1 + n \times \frac{1,75}{100}$
Multiplication factor in decimal form	1,017 5	1,035	1,052 5	1,07	1,0875	...	

- (b) The number pattern of multiplication factors increases by 0,175 in each case – i.e. causes a constant jump in A for each jump of 1 in n .
3. R97 500 (effective interest is $5 \times 6\% = 30\%$ giving a multiplication factor of 1,3)
4. 1,25%
5. (a) R5 035,71 (b) R4 583,92
6. 2 years and 5 months
7. (a) R162,50
(b) R812,50; spend a moment on the fact that $n = 30 \div 6 = 5$ periods of six months
8. As i increases, the gradient, which is equal to Pi increases; link to section on functions and how different values of m affect the graph
9. As in 8, but now both the A -intercept = P and the gradient = iP increase as P increases
10. (a) $1 + 0,017 5 = 1,017 5$
(b) A increases by a multiplying factor of 1,017 5 each month.

Columns swapped because there is no simple way of calculating the interest part of the investment (unlike in simple interest where there is – an additive term) i.e. $A - P$ can only be calculated indirectly by first calculating A .

If you pay me back on	n – number of months you take to repay me	A – the total amount you owe me (to the nearest cent)	$A - P$ – the total interest you owe me (to the nearest cent)
1 March 2015	0	R12 500	R0
1 April 2015	1	R12 718,75	R218,75
1 May 2015	2	R12 941,33	R441,33
1 June 2015	3	R13 167,80	R667,80
1 July 2015	4	R13 398,24	R898,23
1 August 2015	5	R13 632,71	R1 132,71
1 September 2015	6	R13 871,28	R1 371,28
1 October 2015	7	R14 114,03	R1 614,03
1 November 2015	8	R14 361,02	R1 861,02
1 December 2015	9	R14 612,34	R2 112,34
1 January 2016	10	R14 868,06	R2 368,06
1 February 2016	11	R15 128,25	R2 628,25
1 March 2016	12	R15 392,99	R2 892,99

- (c) *Owed to me after 3 months* – R12 500 $(1 + 0,75)^3$
Owed to me after 4 months – R12 500 $(1 + 0,75)^4$
Owed to me after n-months – R12 500 $(1 + 0,75)^n$

Timelines are an important organising tool when dealing with time values; be sure to sell them as such to the learners

- (d) Gets bigger by a factor of $(1 + i)^n$ each month;
 - (e) Calculate $\frac{100 \times (A - P)}{P}$ in each of the three cases.
 - (f) Should get the familiar exponential curve; if a graph looks exponential it doesn't mean that it is exponential; the only way to be sure is to check how the output values change as the input values change
 - (g) A is an exponential function of n ; link P to the coefficient, $(1 + i)$ to the base, b in the section of functions and graphs.
 - (h) Makes mathematical sense because $(1 + i)^0 = 1$, so including $n = 0$ lets the formula output the principal value.
11. R720 122
 12. The value of A in four years' time must be $0,10 \times 600\,000 = R60\,000$; $P = R34\,300$
 13. Square root will have to be taken; $r = 13\%$
 14. R5 338 687

Should he have spent the money or should he have invested it for his retirement. A relatively small amount of money can accrue substantial value under compounding; saving as early as possible is the key (and resisting the urge to spend any of the money in the intervening 40 years!).

15. $A = 2P$ for doubling; from the formula $1,065^n = 2$. A numerical search yields $n = 11$.

The wisdom of her choice depends on her motives; art is not only an investment, but also something beautiful; she may get a lower interest than if she invested the money in a fund, but at least she has something that adds value to her life (the point here is that investment is not investing in wealth but also in life); other purchases, such as a car or top of the range computer does not increase in value but lose value the moment you buy them, so one must be clear-headed about what is and what is not an investment

16.

	1	2	3	4	5
(a)	R600	R720	R864	R1 036,80	R1 244,16
(b)	R1 200	R1 440	1 728	R2 073,60	R2 488,32
(c)	R1 800	R2 160	R2 592	R3 110,40	R3 732,48

Varying P is the same as varying a (link to work on functions and graphs).

17.

	1	2	3	4	5
(a)	R1 100	R1 210	R1 331	R1 464,10	R1 610,51
(b)	R1 200	R1 440	R1 728	R2 073,60	R2 488,32
(c)	R1 300	R1 690	R2 197	R2 856,10	R3 712,93

Increasing i causes the base to increase.

18. (a) R12 260 (b) 12,0%
 (c) He has paid R12 260 more for the bike than if he paid cash; that's quite a bit, but not as bad as in the example where the fridge cost nearly twice as much. The only way to know for sure is to shop around and see what other dealerships are offering (doing one's homework before getting into any financial agreement is very important).
19. (a) R5 245, 65
 (b) R502, 86
 (c) 52,51%
20. R470
21. (a) 75
 (b) R340 000
 (c) 6,07%
 (d) She's retired and probably has her pension; being paid an extra R7 500 per month is very welcome; however, she will have to pay income tax on the extra income; if she sold the flat she would pay no tax on the R560 000 (if it was her only property)
 (e) Probably a very good deal; if they decide they don't like the flat and move out early, they haven't spent much more than they did before; also, their rent at their previous flat will go up every year (as much as 10% p.a.), while Aunt Kitty is not going to increase the rent she is asking. This means that as time goes by, Aunt Kitty's flat becomes better value for money; and, in the end, they will own it; also, the current interest rates for home loans are around 10%, so this is a better deal than buying a flat through the bank
22. R4 756
23. R22,20
24. R18,69
25. (a) 6,96%
 (b) She paid her parents R97 300, so no, she has not.
26. (a) The value will be
 $R560\,000 \times 1,02 \times 1,07 \times 1,005 \times 1,04 \times 1,043 \times 1,038 \times 1,08 \times 1,095 \times 1,11 \times 1,062$
 $= R560\,000 \times 1,721\,672$
 $= R964\,136$
 (b) Yes, since they have effectively paid $R560\,000 + R340\,000 = R900\,000$ for the flat and it is worth more after ten years than they paid for it

27. 4,56%

28. (a)

Month and year	Cost per 100g
January 2008	R7,98
January 2010	R9,97
January 2013	R11,94
January 2015	R14,33

- (b) 11,78% (c) 6,19%
29. (a) $120 \times 10 \times 11,54 = R13\,848$, so yes, just enough (with R152 or \$13,17 to spare)
 (b) R520, but probably more to be safe
 (c) The sudden drop in value of the Rand is bad luck, but not having extra savings for an emergency is bad planning.
30. (a) R9 666 667
 (b) R1 208 333

Can you explain why delays on big projects can cause costs to snowball? Projects that stay on schedule tend to stay within the budget (which usually includes emergency funds – this may be more of an emergency than that!).

31. (a) Weaker compared to both; ZAR1 buys fewer Dollars and fewer Yen
- (b) Sept 2010: $\text{JPY}1 = \frac{0,14}{11,8} = \text{USD } 0,0119$
 Dec 2014: $\text{JPY}1 = \frac{0,0869}{10,3} = \text{USD } 0,00844$
- So, weakened because JPY1 buys fewer Dollars than in 2010
- (c) so $x = \text{Y}29\,631$
- (d) Cost in USD in 2010: so USD 142,37
 Therefore % profit = $\frac{100 \times (250 - 142,37)}{142,37} = 75\%$
- (e) Calculate cost in ZAR: ZAR1016,95
 And sales price: ZAR2876,87
 % profit = 182%
- (f) Both! A good businessman because the USD and JPY were quite stable compared to the Rand, so she bought the book low and sold it high. Lucky, because the Rand lost quite a bit of value, so the poor exchange rate made her profit in ZAR much bigger than her profit in USD or JPY (no one can predict how exchange rates change, so its pure luck if it goes in your favour).
- (g) SARS will charge you tax on any book entering the country;
 If you buy and sell collectable items (usually no tax involved) too frequently SARS will assume you are running a business and tax you (business tax is usually higher than personal tax).
 Both these will reduce the Rand profit percentage.

CONSOLIDATION EXERCISES

- | | |
|---|---|
| <p>1. (a) Andrew
 (b) Andrew (only just)
 (c) Glenton</p> <p>Which is better? Depends how long the investment is held. Andrew's is better up to about 8 years, but somewhere between 8 and 12 years Glenton will do better (compound interest always wins if you give it enough time to accumulate because is exponential in nature)</p> <p>2. Cassandra's after the first year (when they have the same accumulated value)</p> <p>3. (a) 337,20 VEF
 (b) 1 USD = 11,81; ZAR = 9,71; BWP = 6,37; VEF
 (c) 12 tables.
 (d) Venezuela</p> <p>4. (a) 4 months expense.
 (b) R17 599,97
 (c) 303 months expense.</p> <p>5. Retailer A.</p> <p>6. R11 725</p> <p>7. R10 470,33</p> | <p>8. 8,78%</p> <p>9. R21 100</p> <p>10. (a) R36 000
 (b) R11 000
 (c) R750
 (d) R5 500</p> <p>11. 3 weeks</p> <p>12. R12 029,04</p> <p>13. (a) 9,92%
 (b) R10,39</p> <p>14. (a) R99 600
 (b) R13 944
 (c) R16 932
 (d) R130 476</p> <p>15. (a) R19,99
 (b) R27,11</p> <p>16. (a) £ 817 000
 (b) R10 071,43</p> <p>17. (a) 8 517 160 191 people
 (b) 9 062 958 159 people</p> |
|---|---|