

**EC - LEARNER SUPPORT MATERIAL: CIVIL TECHNOLOGY**

**CONSTRUCTION: GRADE 11**

**CONTENT TO BE COVERED:**

**TOPIC: TOOLS, EQUIPMENT AND GRAPHICS**

## **Equipment and Tools (Generic)**

- Identification, proper use and care of the following basic site equipment:
- Identification, proper use and care of the following:

### **Brick cutting tools**

- Identification, proper use and care of the following: Plastering tools, dentification, proper use and care of the following:

### **Woodworking tools**

- Identification of parts, accessories and uses of the following construction machines:
- Identification and use of the following equipment: depended scaffolding, in- depended scaffolding, builders trestle
- tower scaffolding
- putlog scaffold
- mobile scaffold

## **Equipment and Tools (Subject Specific)**

Identification, proper use and care of the following:

### **Cutting tools:**

- Cold chisels
- Tin snips (Bent, straight & universal)
- Files (flat, round, square, triangular and half round)
- Pipe threader (stocks and dies)

### **Holding tools:**

- Pliers
- Bench vice

### **Fastening tools:**

- Spanners (ring, open ended and combination)
- Pop rivet apparatus
- Snapper or riveting tool
- Groove or seaming tool

### **Sheet metal work machines:**

- Guillotine
- Sheet bending machine
- Pan and box bending machine
- Rolling machine

## **GRAPHICS AS MEANS OF COMMUNICATION (SPECIFIC)**

Scale drawings of the following:

- Semi-circular arch
- Segmental rough arch
- Gauged segmental arch.

Freehand sketches of the following:

floor plan of a house with 3 bedrooms, a sitting room, a kitchen, a toilet and a bathroom

## QUESTION 1: TOOLS, EQUIPMENT AND GRAPHICS

1.1 Various options are given as possible answers to the following questions. Choose the answer and write only the letter (A–D) next to the question number (1.1.1–2.1.10) for example 1.1.11 C.

1.1.1 A/An... may be used to sharpen steel drill bits and cold chisels.

- a) angle grinder
- b) flat file
- c) electric drill
- d) bench grinder (1)

1.1.2 A ... may be used to drive in screws fast.

- a) flat screwdriver
- b) power screwdriver
- c) Phillips screwdriver
- d) crow bar (1)

1.1.3 A/An ... is used to cut grooves into brick walls.

- a) portable circular saw
- b) club hammer
- c) angle grinder
- d) electric drill (1)

1.1.4 A ... may be used to cut the rafters of an installed roof truss to the correct length.

- a) radial arm saw
- b) portable circular saw
- c) rip saw
- d) cutting gauge (1)

1.1.5 A ... is the most effective tool to mix large quantities of concrete on a building site.

- a) round-nose shovel
- b) square-nose shovel
- c) spade
- d) concrete mixer (1)

1.1.6 A ... is used to compact loose soil up to a depth of 300 mm.

- plate compactor
- concrete vibrator
- rammer
- straight edge (1)

1.1.7 ... may be used to tighten cup nuts in difficult-to-reach spaces behind sanitary appliances.

- a) Water pump pliers
  - b) A basin wrench
  - c) A corner trowel
  - d) Universal pliers
- (1)

1.1.8 A ... may be used to drive in small nails, like panel pins.

- a) club hammer
  - b) claw hammer
  - c) ball-pene hammer
  - d) cross-pene hammer
- (1)

1.1.9 A ... may be used to copy angles to transfer them to other surfaces.

- a) sliding bevel
  - b) mitre square
  - c) combination square
  - d) combination plane
- (1)

1.1.10 A ... may be used to plane long planks to obtain a straight surface.

- a) smoothing plane
  - b) jack plane
  - c) trying plane
  - d) All the above-mentioned
- (1)

1.2 FIGURE 1.2 below shows a hand tool and one piece of site equipment.

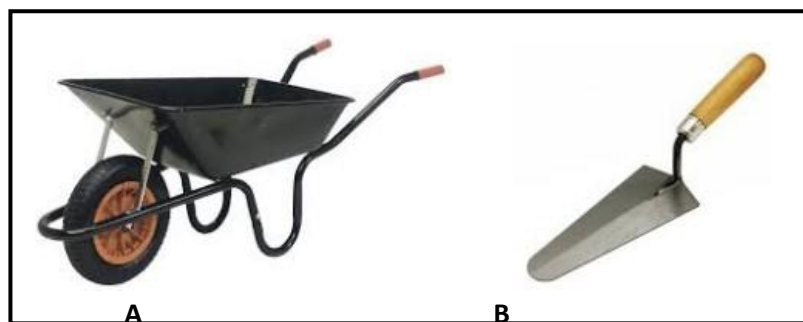

**FIGURE 1.2**

1.2.1 Identify **A** and **B**. (2)

1.2.2 Explain ONE use of **A** and **B**. (2)

1.2.3 Explain the care of a used cold chisel. (1)

1.3 Draw to scale 1: 2 an isometric view of a common brick. (5)

1.4 Make a neat freehand drawing, in good proportion, of the sectional view part of the superstructure of a building.

Show the following on your drawing:

- Part of the wall below the window
- External window sill                      Internal window sill
- Window frame
- TWO lintels above the window
- Part of the wall above the window

(9)

1.5 **FIGURE 1.5** below shows the floor plan of a building. Study the drawing and answer the questions that follow.

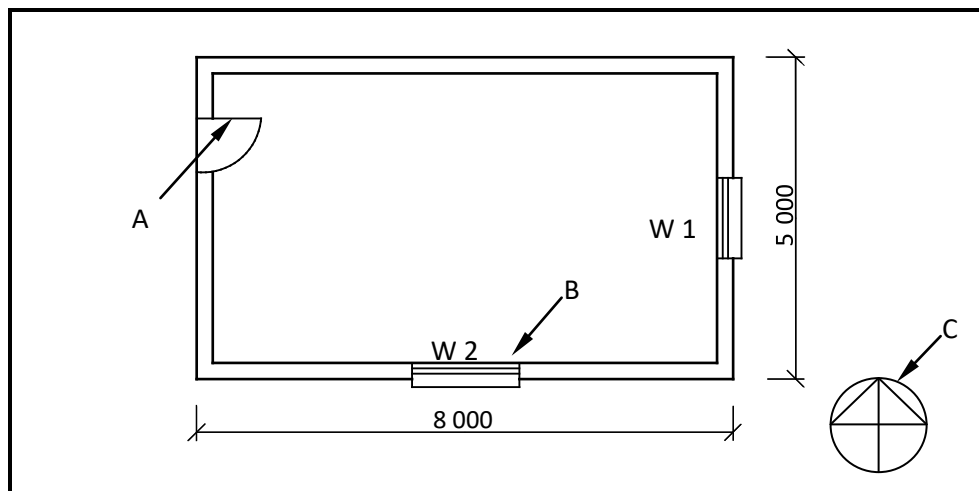

**FIGURE 1.5**

Identify parts **A**, **B** and **C**. (3)

Develop and draw, to scale 1: 50, the east elevation of the building.

Use the following specifications:

- The building has a gable roof with a pitch of 30°.
- Window 1 is 1 500 mm wide and 1 200 mm high.
- Window 2 is 2 000 mm wide and 1 200 mm high.
- All windows are placed in the middle of the walls.
- The door is 2 000 mm high and 900 mm wide.
- The height from the natural ground level to the finished floor level is 300
- The height of the superstructure is 2 700 mm.
- The roof is finished off with 220 mm barge boards and no gutters are fitted.

(8)

**[40]**

## ANSWER: QUESTION 1: TOOLS, EQUIPMENT AND GRAPHICS

1.1 1.1.1 D ✓

1.1.2 B ✓

1.1.3 C ✓

1.1.4 B ✓

1.1.5 D ✓

1.1.6 C ✓

1.1.7 B ✓

1.1.8 D ✓

2.1.9 A ✓

2.1.10 C ✓ (10)

1.2 1.2.1 A – Wheel barrow ✓ B – Nosing trowel ✓ (2)

1.2.2 A: Wheelbarrow can be used to transport fresh concrete, bricks, stone or other building material on a building site. ✓ (1)

B: A nosing trowel is used:

- To mix gypsum plaster ✓
- To mix small amounts of plaster on the hand hawk
- For patchwork on mouldings
- To touch up small areas that needs to be plastered or filled (1)

1.2.3 • Sharpen it regularly. ✓

- Grind down the mushroom heads on the hammer end regularly.
- Oil lightly to prevent rust when storing the tool for a long time, and wipe off the oil properly before use. (1)

1.3

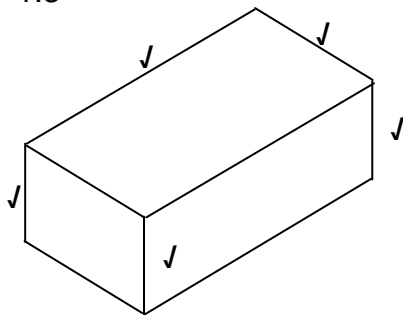

SCALE 1 : 2

NOT TO SCALE: USE A MASK TO MARK THIS QUESTION.

(5)

2.4

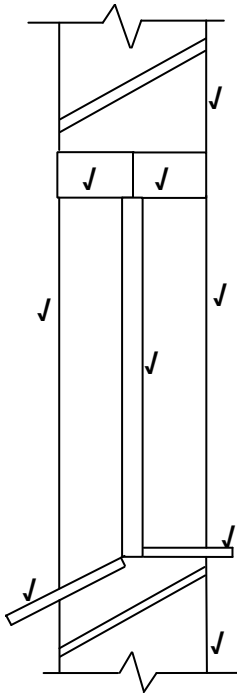

(9)

ASSESSMENT CRITERIA	MARKS	LEARNER'S MARK
Wall above window	1	
Wall below window	1	
Lintels	2	
Window frame	1	
External window sill	1	
Internal window sill	1	
Reveals	2	
TOTAL	9	

2.5 2.5.1 A- Door ✓

B- Window ✓

C- North point ✓

(3)

2.5.2

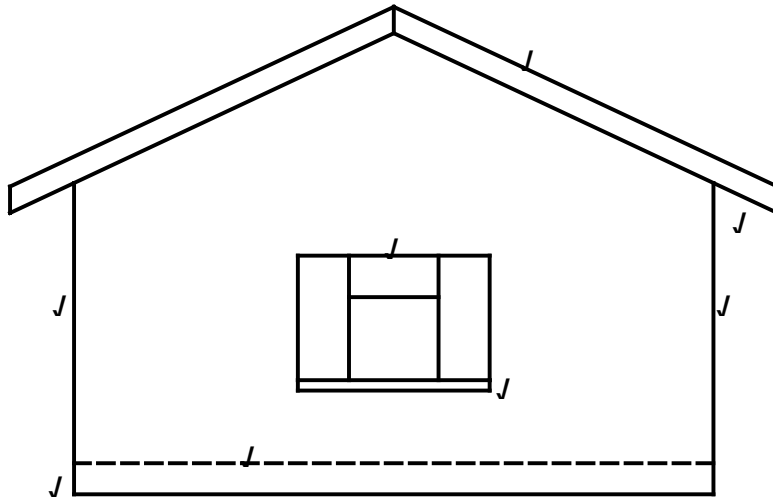

**NOT TO SCALE: USE A MASK TO MARK THIS QUESTION.**

ASSESSMENT CRITERIA	MARKS	LEARNER'S MARK
External walls	2	
Natural ground level	1	
Finished floor level	1	
Window	1	
Window sill	1	
Barge board	1	
Verge overhang	1	
<b>TOTAL</b>	<b>8</b>	

(8)

[40]



**EXAMPLE 2: QUESTION 2: EQUIPMENT, TOOLS AND GRAPHICS (GENERIC)**

2.1 Answer the following questions with regard to the hand tool in **FIGURE 2.1**.

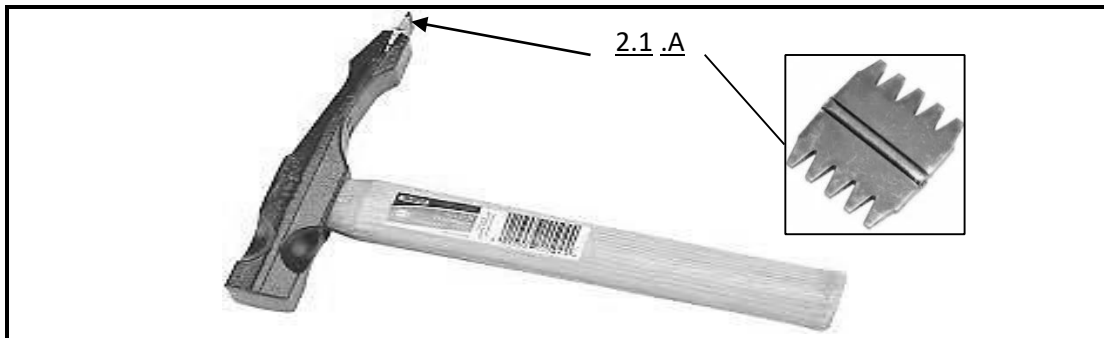

**FIGURE 2.1**

2.1.1 What is this tool called? (1)

2.1.2 Describe the purpose of part 2.1.A. (2)

2.1.3 Briefly motivate why part 2.1.A must be replaced regularly. (2)

2.2 Identify the tool in **FIGURE 2.2** and name THREE measures that should be taken to care for it. (4)



**FIGURE 2.2**

2.3 Identify the tool in **FIGURE 2.3** and name THREE measures that should be taken to care for it. (4)

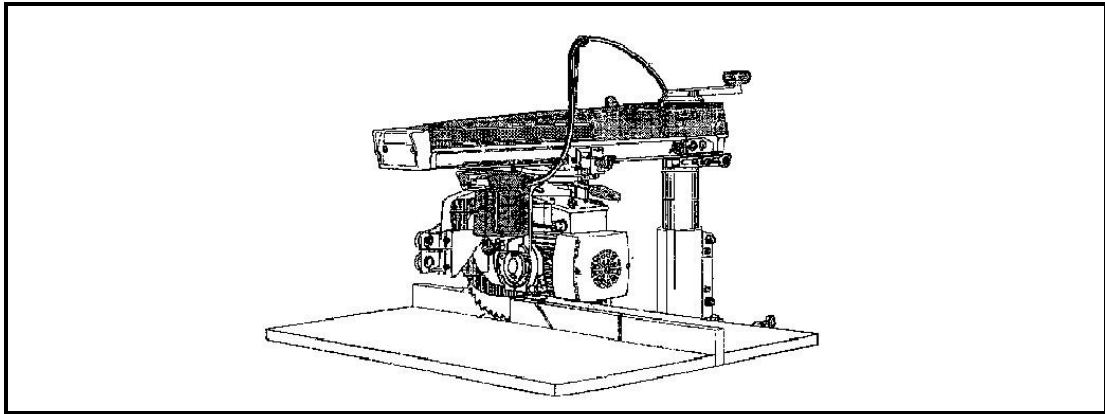

FIGURE 2.3

- 2.4 Name TWO measures for caring for a concrete mixer. (2 x 1) (2)
- 2.5 Answer the following questions with regard to the plan elevation in FIGURE 2.5.

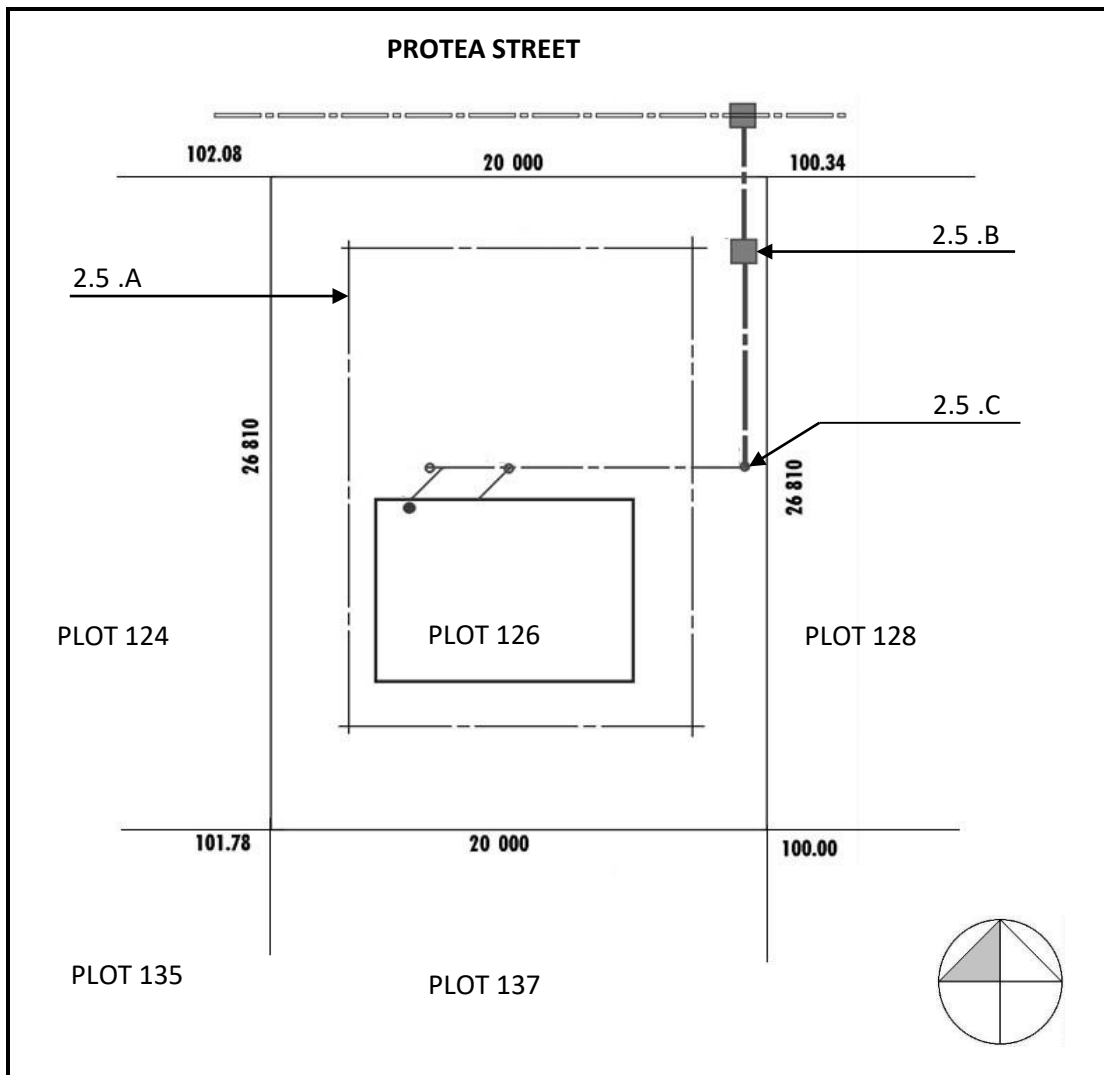
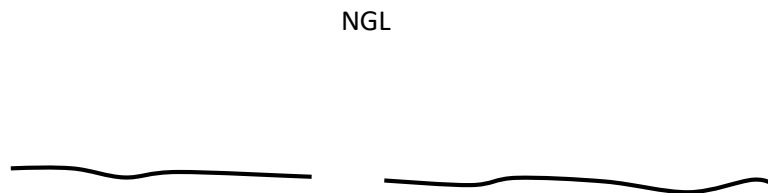

FIGURE 2.5

- 2.5.1 What is the plan elevation called? (1)

- 2.5.2 What is the plot number of the plot on the west side of plot 126? (1)
- 2.5.3 What are the lines at 2.5.A called? (1)
- 2.5.4 Identify the symbols at 2.5.B and 2.5.C. (2)

2.6 **FIGURE 2.6**, shows an incomplete section view of a single brick wall. Complete the section view to scale 1: 20 and show the following parts with symbols and labels:



- 2.6.1 A strip foundation of 700 x 250 mm with the invert level of 400 mm (3)
- 2.6.2 A single brick wall with a height of 2 700 mm from the floor level and 10 mm plaster work on the outside and inside (5)
- 2.6.3 The hardcore filling of 250 mm (1)
- 2.6.4 The dampproof course (2)
- 2.6.5 The blinding layer of 50 mm (1)
- 2.6.6 The concrete floor slab of 90 mm (1)
- 2.6.7 A door opening with a height of 2 100 mm (1)
- 2.6.8 A concrete lintel with a thickness of 70 mm above the door opening (2)
- 2.6.9 A wall plate of 114 x 38 mm (2)
- 2.6.10 Show any TWO labels. (2 x 1) (2)

**[40]**

## ANSWER: QUESTION 2: EQUIPMENT, TOOLS AND GRAPHICS (GENERIC)

- 2.1 2.1.1 Comb hammer (1)
- 2.1.2 Steel comb, finish bricks, blocks/roughen smooth surfaces (2)
- 2.1.3 (1) Hammering on hard bricks (2) decays the comb / make comb blunt (2)
- 2.2 (1) Mitre try square Any **THREE** uses of it. (3)
- Testing squareness
  - Marking out perpendicular lines
  - Can be used as a ruler
  - Marking square lines
  - Test if surfaces are straight
  - Drawing 45° lines
- (4)
- 2.3 (1) Radial arm saw  
Any **THREE** caring measures for it. (3)
- Maintain – lubricate and adjust according to instructions
  - Clean after use
  - Repair damaged electrical cords
  - Handle with care not to damage accuracy
  - Use only for intended purpose
  - Do not force the saw
  - Avoid blunt blades
  - Keep ventilation holes open
  - Service regularly
- (4)
- 2.4 Any **TWO** caring measures for a concrete mixer.
- Clean inside after use
  - Do not leave water in the drum
  - Oil inside of drum when storing for a long time (2 x 1) (2)
- 2.5 2.5.1 Site plan (1)
- 2.5.2 124 (1)
- 2.5.3 Building boundary (1)
- 2.5.4 (2.5.B – Manhole)
- 2.5.5 (2.5.C – Rodding eye) (2)
- 2.6 **FIGURE 2.6** shows an incomplete section view of a single brick wall.  
Complete the section view on scale 1: 20 and show the following parts with

symbols and labels:

- 2.6.1 A strip foundation of 700 x 250 mm with the invert level of 400 mm (3)
- 2.6.2 A single brick wall with a height of 2 700 mm from the floor level and 10 mm plaster work on the outside and inside (5)
- 2.6.3 The hard-core filling of 250 mm (1)
- 2.6.4 The damp proof course (2)
- 2.6.5 The blinding layer of 50 mm (1)
- 2.6.6 The concrete floor slab of 90 mm (1)
- 2.6.7 A door opening with a height of 2 100 mm (1)
- 2.6.8 A concrete lintel with a thickness of 70 mm above the door opening (2)
- 2.6.9 A wall plate of 114 x 38 mm (2)
- 2.10 Show any TWO labels. (2 x 1) (2)

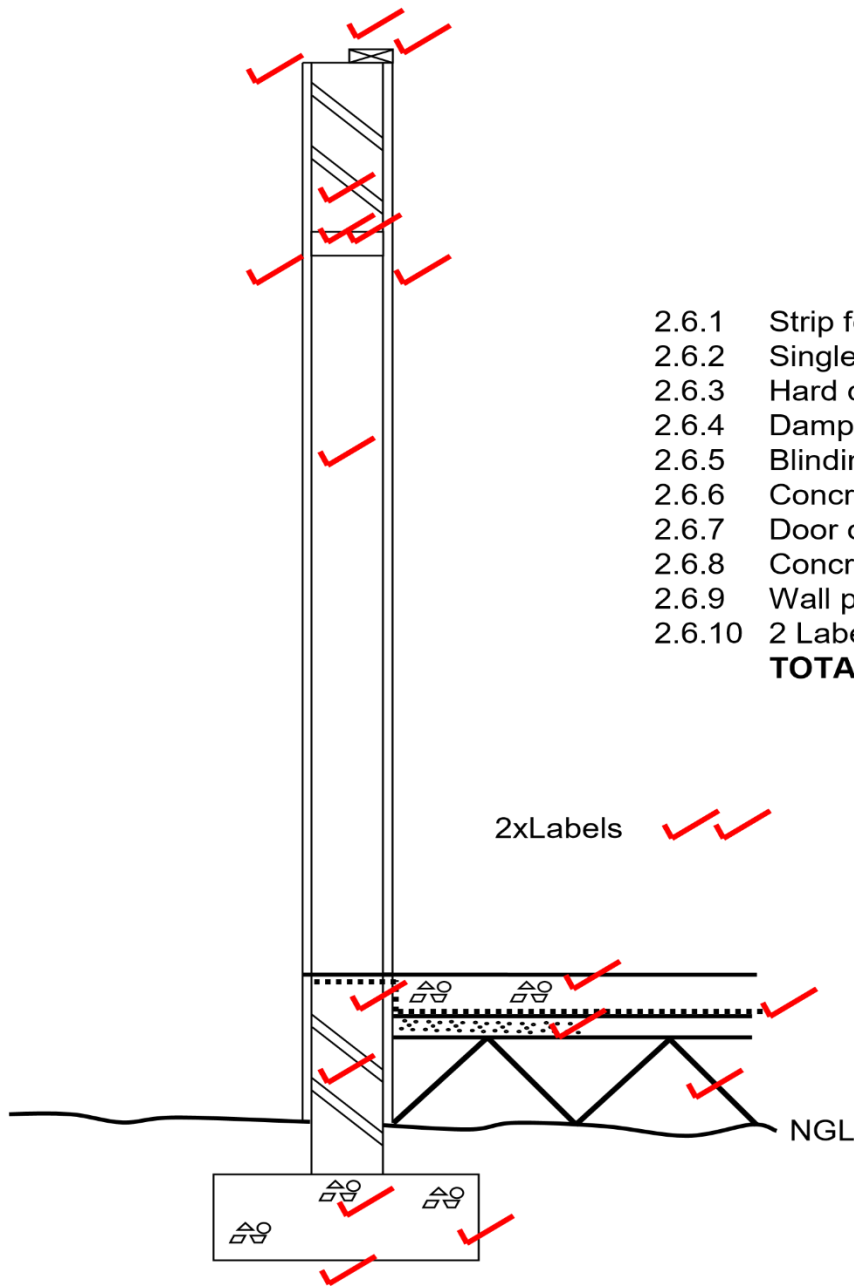

2.6.1	Strip foundation	3
2.6.2	Single brick wall	5
2.6.3	Hard core filling	1
2.6.4	Damp proof course	2
2.6.5	Blinding layer	1
2.6.6	Concrete floor slab	1
2.6.7	Door opening	1
2.6.8	Concrete lintel	2
2.6.9	Wall plate	2
2.6.10	2 Labels	2
	<b>TOTAL</b>	<b>20</b>

2xLabels

NGL

**EXAMPLE 3: QUESTION 3: EQUIPMENT, TOOLS AND GRAPHICS (GENERIC)**

3.1 Name the tools in **FIGURES 3.1.1 to 3.1.4** and name ONE use of each.

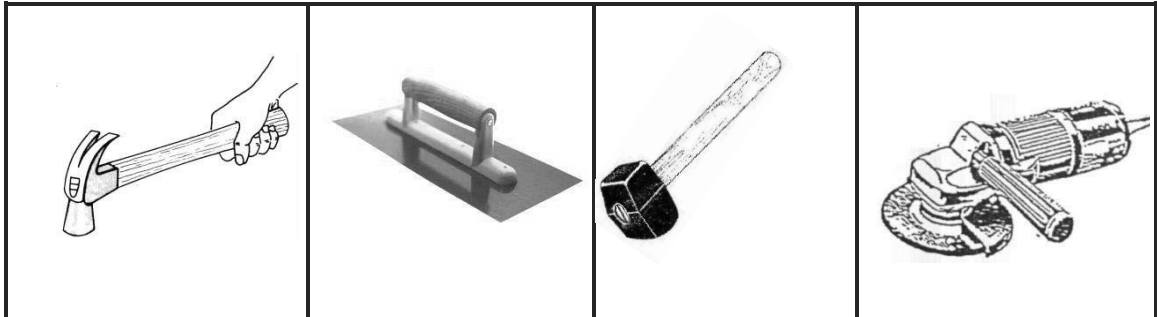

**FIGURE 3.1.1**

**FIGURE 3.1.2**

**FIGURE 3.1.3**

**FIGURE 3.1.4**

(4 x 2)  
(8)

3.2 Which power tool will be used for the following work:

3.2.1 Sharpening of chisels (1)

3.2.2 To cut rebates in wood (1)

3.3 Identify the tool in **FIGURE 3.3** and name TWO uses of it.



**FIGURE 3.3**

(3 x 1) (3)

3.4 Name TWO maintenance measures which are applicable to straight edges.

(2 x 1) (2)

3.5 Briefly motivate why universal pliers cannot be used for clamping plumbing pipes. (1)

3.6 Answer the following questions with regard to the elevation in **FIGURE 3.6**.

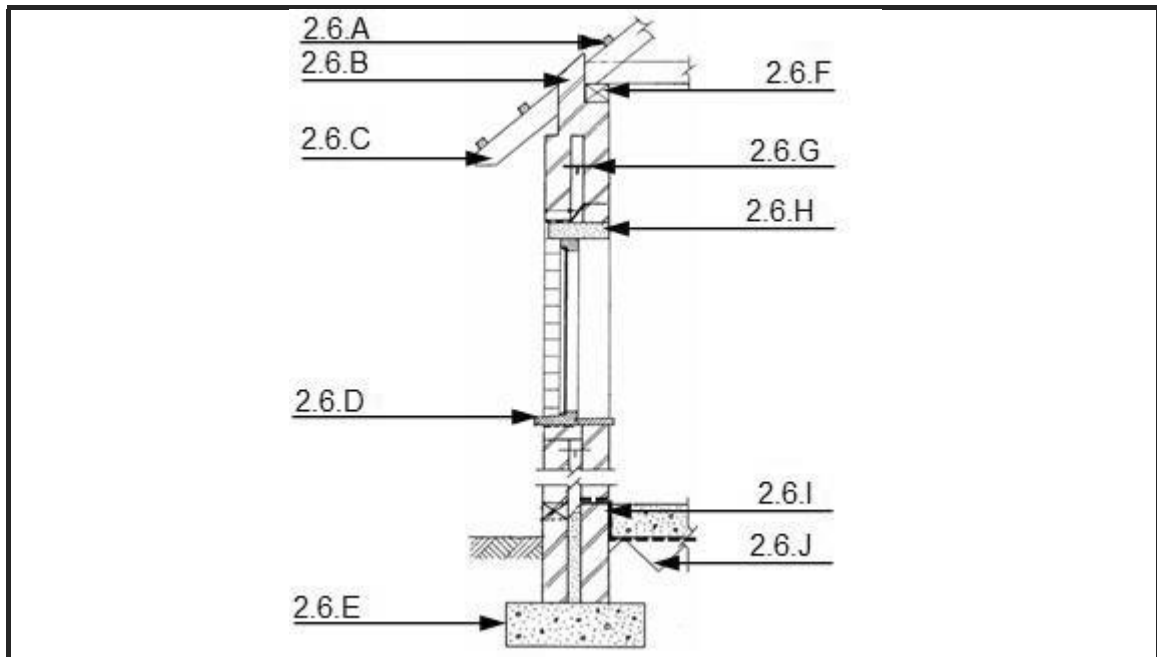

**FIGURE 3.6**

Name the type of elevation. (1)

3.6.1 Name the parts labelled 2.6.A to 2.6.J. (10)

3.6.2 What are the width and thickness dimensions of part 2.6.F? (2)

3.6.3 What is the purpose of part 2.6.G? (1)

3.7 Name FOUR particularities with regard to roof constructions which must be indicated in elevations. (4 x 1)

(4)

3.8 Make neat sketches to illustrate the following symbols:

3.8.1 Plaster (2)

3.8.2 Undressed wood (2)

3.8.3 Invert level (2)



### ANSWER 3: QUESTION 3: EQUIPMENT, TOOLS AND GRAPHICS (GENERIC)

3.1 Name the tools in FIGURES 3.1.1 to 3.1.4 and name ONE use of each.

3.1.1 Claw hammer

Any ONE use:

- General carpentry / Driving in nails
- Remove nails (2)

3.1.2 Plastering trowel

- Smooth finishing for walls / plaster work (2)

3.1.3 Club hammer

Any ONE use:

- Driving brick bolster / cold chisel
- Where heavy hammering is needed
- Driving pegs into the ground (2)

3.1.4 Angle  
grinder  
Any ONE  
use:

- Cutting stone / concrete / tiles / metals
- Can be used as a grinder (2)

3.2 3.2.1 Bench grinder (1)

3.2.2 Portable circular saw / Radial arm saw (1)

3.3 Identify the tool in FIGURE 3.3 and name TWO uses of it.

Plate compacter

Any TWO uses:

- Compacting disturbed / loose soil up to 150 mm
- Tampering fillings for hardcore layer
- Compacting soil for paving bricks (3 x 1) (3)

3.4 Wipe clean after use

- Do not allow mortar / concrete / screed to dry on it
  - Store in a dry place
- (Any 2 x 1) (2)

3.5 Similar answer:  
The jaws of the universal pliers cannot open big enough (1)

3.6  
3.6.1 Section view (1)

- 3.6.2 3.6. A – Purline  
 3.6.B – Beam filling  
 3.6.C – Rafter  
 3.6.D – Window sill  
 3.6.E – Foundation  
 3.6.F – Wall plate  
 3.6.G – Wall tie  
 3.6.H – Lintel  
 3.6.I – Damp proof coarse  
 3.6.J – Hard core (10)

3.6.3 114 x 38 (2)

3.6.4 Bind 2 wall leaves (1)

3.7  Pitch of roof

- Type of roof covering
  - Barge board
  - Facia board
  - Gutters
  - Downpipes
- (Any 4 x 1) (4)

3.8 .8.1 Plaster  (2)

 3.8.2 Undressed wood (2)

 3.8.3 Invert level (2)

**[40]**